

# MODEL 3700 FRONT FOLDING PLANTER OPERATOR MANUAL

**M0233-01**

**Rev. 10/11**

This manual is applicable to: Model 3700 Forward Folding Planters

Record the model number and serial number of your planter along with date purchased:

Model Number \_\_\_\_\_ 3700 \_\_\_\_\_

Serial Number \_\_\_\_\_

Date Purchased \_\_\_\_\_

Monitor Serial Number _____
Measured Pulses Per Mile/Km (Radar Distance Sensor) _____
Measured Pulses Per Mile/ Km (Magnetic Distance Sensor) _____

## SERIAL NUMBER

The serial number plate is located on the planter frame as shown below. The serial number provides important information about your planter and is needed to obtain correct replacement parts. Always provide model number and serial number to your Kinze Dealer when ordering parts or when contacting Kinze Manufacturing, Inc.

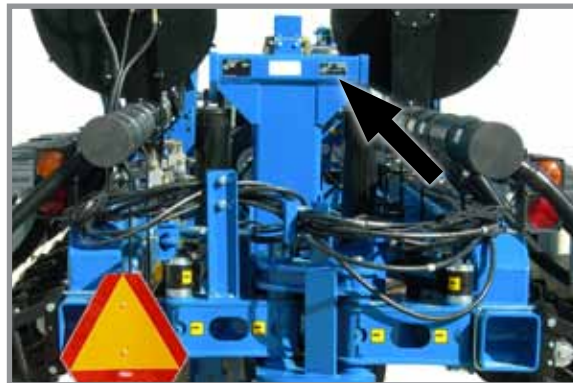

**Serial number plate location**

**This page intentionally left blank.**

Kinze Manufacturing, Inc. thanks you for your patronage. We appreciate your confidence in Kinze farm machinery. Your Kinze planter has been carefully designed to provide dependable operation in return for your investment.

**This manual has been prepared to aid you in the operation and maintenance of the planter. It should be considered a permanent part of the machine and remain with the machine when you sell it.**

It is the responsibility of the user to read and understand the Operator Manual in regards to safety, operation, lubrication and maintenance before operation of this equipment. It is the user's responsibility to inspect and service the machine routinely as directed in the Operator Manual. We have attempted to cover all areas of safety, operation, lubrication and maintenance; however, there may be times when special care must be taken to fit your conditions.

Throughout this manual the symbol  and the words **DANGER**, **WARNING**, and **CAUTION** are used to call attention to safety information that if not followed, will or could result in death or injury. **NOTICE** and **NOTE** are used to call your attention to important information. The definition of each of these terms follows:



**DANGER** Indicates a hazardous situation which, if not avoided, will result in death or serious injury.



**WARNING** Indicates a hazardous situation which, if not avoided, could result in death or serious injury.



**CAUTION**, used with the safety alert symbol, indicates a hazardous situation which, if not avoided, could result in minor or moderate injury.

**NOTICE** is used to address practices not related to personal injury.

**NOTE:** Special point of information or machine adjustment instructions.



### **WARNING**

Improperly operating or working on this equipment could result in death or serious injury. Read and follow all instructions in Operator Manual before operating or working on this equipment.



### **WARNING**

Some photos in this manual may show safety covers, shields, or lockup devices removed for visual clarity. **NEVER OPERATE OR WORK ON** machine without all safety covers, shields, and lockup devices in place as required.

**NOTE:** Photos in this manual may be of prototype machines. Production machines may vary in appearance.

**NOTE:** Some photos and illustrations in this manual show optional attachments installed. Contact your Kinze Dealer for purchase of optional attachments.

**This page left blank intentionally.**

## Specifications

Specification	Conventional Hoppers		Air Seed Delivery (ASD)	
	24R 20	24R N 30	24R N 30	36R N 20
Number of Rows	24R 20	24R N 30	24R N 30	36R N 20
Row Spacing	20"	30"	30"	20"
Weight Empty (Mechanical)	18,300 lb	20,348 lb	25,180 lb	26,872 lb
Weight Empty (EdgeVac)	---	21,743	---	---
Transport Height	10'-9"	11'-7"	13'-0"	12'-10"
Planting Length	27'-4"	30'-11"	30'-11"	30'-11"
Transport Length	32'-0"	36'-11"	40' 2"	40' 2"
Planting Width	43' 11"	62'-9"	62' 9"	63' 9"
Transport Width (14'-0" with granular chemical option)	13'-3"	13'-0"	13'-8"	13'-8"
Seed Capacity	1.90 bu. / hopper	1.75 bu.	110 bu.	
ASD Fill Dimensions (planting position)			8' 7"	
Transport Tire Size	(4) 36 x 16-17.5 rib duplex 14-ply tubeless			
Transport Tire Pressure	75 psi			
Wing/Lift Tires	(4 - 24R, 6 - 36R) 7.5" x 20", 8-ply, Tubeless Rib Implement			
Field Tire Pressure	40 psi			
Contact Drive Tires	(4) 4.80 x 8"			
Piston Pump Drive Tires (Optional)	(2) 7.60" x 15"			
Field Lift	Four Master/Two Slave Hydraulics			
Row Markers	Independently controlled, three stage, low profile equipped disk blade depth bands.			

## Tractor Hydraulic Requirements

Configuration	Requirements		Description
<i>Base machine with mechanical meters</i>	2 SCV	15 gpm	#1 SCV: planter lift
			#2 SCV: markers / fold (with 12v control console)
<i>Base machine with mechanical meters Air seed delivery (ASD) system</i>	3 SCV	25 gpm	#1 SCV: planter lift
			#2 SCV: markers / fold (with 12v control console)
			#3 SCV: ASD system
<i>Base machine with EdgeVac meters Tractor mounted PTO hydraulic pump</i>	2 SCV	15 gpm	#1 SCV: planter lift
			#2 SCV: markers / fold (with 12v control console)

**NOTE: Tractor-mounted PTO hydraulic pump supplies oil flow for EdgeVac hydraulic circuit.**

1. Read and understand instructions provided in this manual and warning labels. Review these instructions frequently!
2. This machine is designed and built with your safety in mind. Do not make any alterations or changes to this machine. Any alteration to design or construction may create safety hazards.
3. A large portion of farm accidents happen from fatigue or carelessness. Safe and careful operation of tractor and planter will help prevent accidents.
4. Never allow planter to be operated by anyone unfamiliar with operation of all functions of the unit. Operators must read and thoroughly understand all instructions given in this manual before operating or working on equipment.
5. Be aware of bystanders, particularly children! Always look around to make sure it is safe to start tow vehicle engine or move planter. This is particularly important with higher noise levels and quiet cabs, as you may not hear people shouting.
6. Make sure planter weight does not exceed towing capacity of tractor, or bridge and road limits. This is critical to maintain safe control and prevent death or injury, or property and equipment damage.
7. Never ride or allow others to ride on planter.
8. Store planter in an area away from human activity. DO NOT permit children to play on or around the stored unit.
9. Keep hands, feet, and clothing away from moving parts. Do not wear loose-fitting clothing which may catch in moving parts.
10. Always wear protective clothing, shoes, gloves, and hearing and eye protection applicable for the situation.
11. Do not allow anyone to stand between tongue or hitch and towing vehicle when backing up to planter.
13. Prevent electrocution, other injuries, or property and equipment damage. Watch for obstructions such as wires, tree limbs, etc. when operating machine. Be aware of clearances during turns and when folding/unfolding planter.
14. Reinstall all guards removed for maintenance activities. Never leave guards off during operation.
15. Use of aftermarket hydraulic, electric, or PTO drives may create serious safety hazards to you and people nearby. If you install such drives, follow all appropriate safety standards and practices to protect you and others near this planter from injury.
16. Follow all federal, state/provincial and local regulations when towing farm equipment on a public highway. Use safety chain (not an elastic or nylon/plastic tow strap) to retain connection between towing and towed machines in the event of primary attaching system separation.
17. Make sure all safety/warning lights, SMV sign, and reflective decals are in place and working properly before transporting the machine on public roads.
18. Limit towing speed to 15 MPH. Tow only with farm tractor of a minimum 90 HP. Allow for unit length when making turns.
19. Reduce speed prior to turns to avoid the risk of overturning. Always drive at a safe speed relative to local conditions and ensure your speed is slow enough for a safe emergency stop.
20. Chemical application is often an integral part of planting. Follow label instructions for proper chemical mixing, handling and container disposal methods.
21. Be familiar with safety procedures for immediate first aid should you accidentally contact chemical substances.
22. Use the proper protective clothing and safety equipment when handling chemicals.
23. Chemicals are supplied with Material Safety Data Sheets (MSDS) that provide full information about the chemical, its effects on exposure, and first aid needs in the event of an emergency. Keep your MSDS file up-to-date and available for first responders in case of emergency.
24. When servicing ground engaging components such as opening disks and firming points, use special care to avoid points and edges worn sharp during use.
25. Use professional help if you are unfamiliar with working on hydraulic systems. Pressurized hydraulic fluid can penetrate body tissue and result in death, serious infection, or other injuries.

Following are some common hazard warnings associated with this equipment. Pay close attention to all safety, operating, and maintenance information in this manual and decals applied to your equipment.

 **DANGER!**

Contacting or coming close to power lines or other high energy sources will cause death or serious injury. Keep away from power lines or high energy sources at all times.

 **WARNING**

Improperly operating or working on this equipment could result in death or serious injury. Read and follow all instructions in Operator Manual before operating or working on this equipment.

 **WARNING**

Falling equipment can cause death or serious injury. Install all lockup devices or lower planter to ground before working on equipment.

 **WARNING**

Explosive separation of rim and tire parts can cause death or serious injury. Overinflation, rim and tire servicing, improper use of rims and tires, or worn or improperly maintained tires could result in a tire explosion.

## SAFETY SIGNS AND DECALS

 **WARNING**

All safety/warning lights, reflective decals, and SMV sign must be in place and visible before transporting machine on public roads or death, serious injury, and damage to property and equipment may result. Check federal, state/provincial, and local regulations before transporting equipment on public roads.

Safety signs and decals are placed on the machine to warn of hazards and provide important operating and maintenance instructions. Information on these signs are for your personal safety and the safety of those around you. FOLLOW ALL SAFETY INSTRUCTIONS!

- Keep signs clean so they can be easily seen. Wash with soap and water or cleaning solution as required.
- Replace safety signs if damaged, painted over, or missing.
- Check reflective decals and SMV sign periodically. Replace if they show any loss of reflective properties.
- Clean machine surface thoroughly with soap and water or cleaning solution to remove all dirt and grease when replacing decals.

**NOTE:** Safety sign and decal locations are shown in the Parts Manual for this machine.

**NOTE:** Style and locations of SMV sign, reflective decals, and safety/warning lights conform to ANSI/ASABE S279.14 JUL 2008 and ANSI/ASABE S276.6 JAN 2005.

**This page intentionally left blank.**

## PLANTER LIFT SAFETY LOCKUP

### WARNING

Uncontrolled machine movement can crush or cause loss of control resulting in death, serious injury, or damage to property and equipment. Install all safety lockup devices before working under or transporting this equipment.

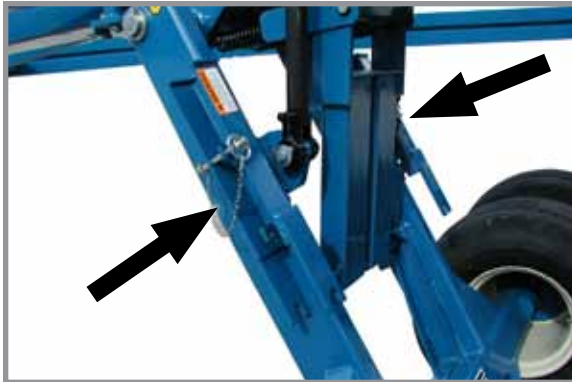

Safety lockup in storage position

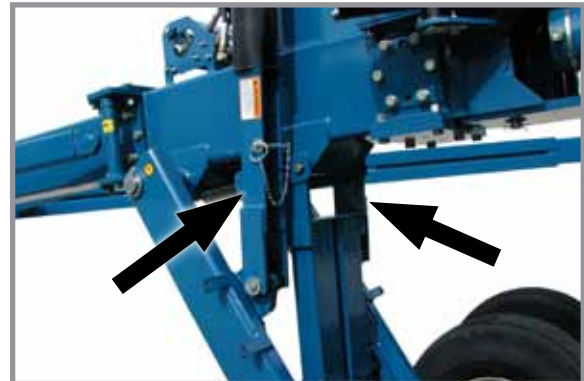

Safety lockup in transport/maintenance position

Planter lift safety lockup is installed between lift cylinder and wheel lift arm. It is held in place by a pin and lynch pin. Remove safety lockup and store on hose take-up for field operation.

## ROW MARKER SAFETY LOCKUP

### WARNING

Row marker can lower at any time and could cause death or serious injury. Stay away from row markers! Install safety lockup device when not in use.



Row marker safety lockup stored

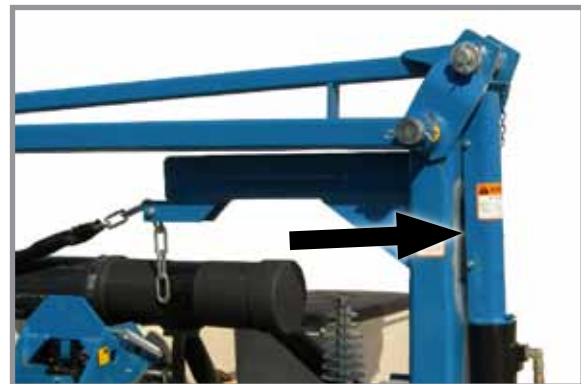

Row marker safety lockup installed

Always install row marker lockups when working on, storing, or transporting planter. Hold in place with two clevis pins.

**⚠ WARNING**

Planter hitch may raise uncontrollably during folding/unfolding and can cause death, serious injury, or damage property and equipment. **DO NOT** fold or unfold planter without planter attached to a tractor. **DO NOT** unhitch planter from tractor unless fully folded for transport or fully unfolded with planting units lowered to ground.

**⚠ WARNING**

Uncontrolled movement of equipment can cause loss of control and could result in death, serious injury, or damage to property and equipment. Install all safety pins before transporting equipment.

**HITCH PARALLEL LINKAGE LOCKUP**

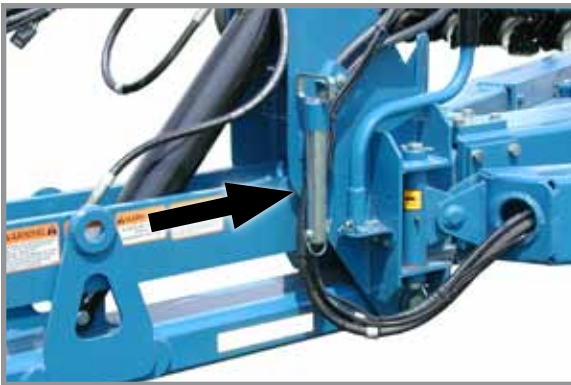

Hitch parallel linkage pin stored

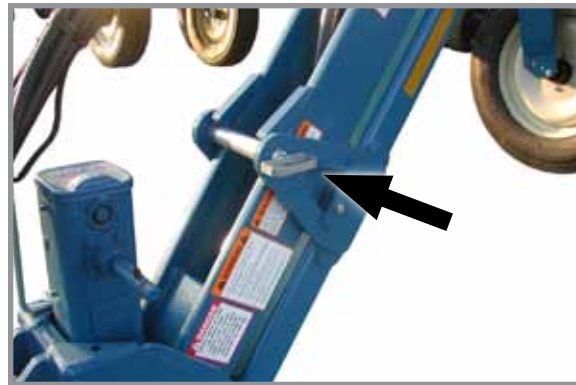

Hitch parallel linkage pin installed

A hitch parallel linkage lock pin locks hitch parallel linkage in raised (transport) position.

**2-SPEED JACK ASSEMBLY**



Jack handle stored

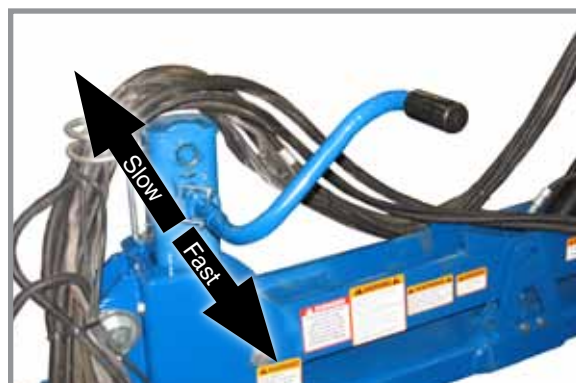

Jack handle installed

Store jack on L.H. side of hitch. Secure in place with spring pin. Install jack on hitch post and secure in place with spring pin. Pull out on handle for high speed or push in on handle for low speed operation.

### WARNING

Improperly operating or working on this equipment could result in death or serious injury. Read and follow all instructions in Operator Manual before operating or working on this equipment.

## INITIAL PLANTER PREPARATION

Following information is general in nature to aid in preparation of tractor and planter for use, and to provide general operating procedures. Operator experience, familiarity with the machine, and the following information should combine for efficient planter operation and good working habits.

### WARNING

Explosive separation of rim and tire can cause death or serious injury. Overinflation, rim and tire servicing, improper use of rims and tires, worn, or improperly maintained tires could result in a tire explosion.

### WARNING

Wheel separation can cause loss of control resulting in death, serious injury, or damage to property and equipment. Check lug nuts on transport wheels are tight before operating planter for first time and periodically after.

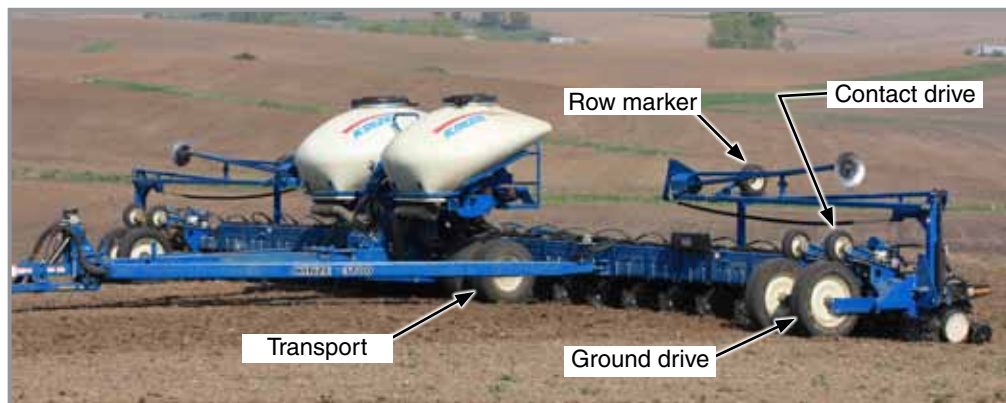

**Tire locations**

1. Torque transport wheel  $\frac{3}{4}$ " - 16 lug nuts to 200 ft-lb (244 N-m).
2. Inflate tires to the following specifications:
  - Ground drive (wings) - 225 x 70R 22.5 - 75 psi (517.1 kPa)
  - Transport - 36" x 16" x 17.5" - 75 psi (517.1 kPa)
  - Contact drive - 4.80" x 8" - 50 psi (344.7 kPa)
  - Row marker - 16" x 6.5" x 8" - 14 psi (96.5 kPa)
  - Liquid fertilizer piston pump (not shown) - 4.10" x 6" - 50 psi (344.7 kPa)
3. Lubricate planter and row units per lubrication information in this manual.
4. Check all drive chains for proper tension, alignment, and lubrication.

**TRACTOR REQUIREMENTS**

**! WARNING**

**Loss of control of equipment during transport can result in death, serious injury, or damage to property and equipment. Tractor gross weight must be greater than planter gross weight with attachments and options.**

Consult your dealer for information on horsepower requirements and tractor compatibility. Requirements vary with planter options, tillage, and terrain.

Two dual remote hydraulic outlets (SCV) are required on all sizes of conventional planters equipped with row markers.

Four dual remote hydraulic outlets (SCV) are required on all sizes of ASD planters equipped with row markers. A 12 volt DC electrical system is required on all sizes.

**EDGEVAC TRACTOR MOUNTED PTO PUMP AND PLANTER MOUNTED HYDRAULICS**



**Two-section PTO hydraulic pump**



**8 gal (30.3 L) reservoir**

Edgevac equipped planters require a 1¼"-20 spline 1000 RPM PTO to operate PTO-driven two section hydraulic pump capable of supplying 15 gpm (56.8 Lpm) to two hydraulic motors/vacuum fans.

EdgeVac Seed Metering System operates from an 8 gal (30.3 L) capacity oil reservoir.

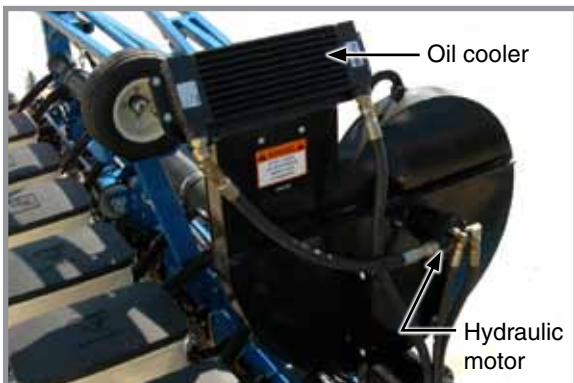

**Vacuum fan assembly with oil cooler**

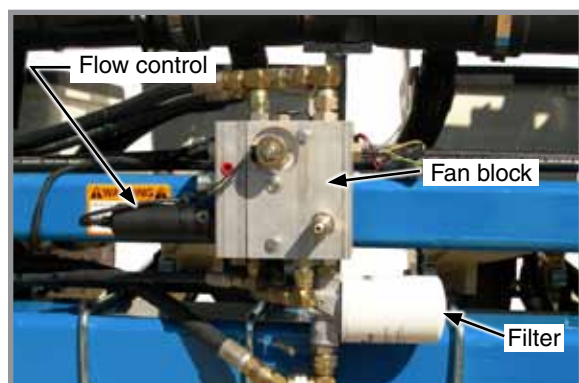

**Vacuum fan block and filter**

Other dual fan system components include two oil coolers, two replaceable cartridge-type filters, two motorized flow controls, pressure compensating valves, solenoid valves, and relief valves.

## TRACTOR PREPARATION AND HOOKUP



Planter control console



Digital vacuum gauge control console

1. Install planter control console (all) and digital vacuum gauge (EdgeVac only) control consoles on tractor in convenient locations within operator reach and close to hydraulic controls. Mount control consoles securely and route power cables to power source. A power lead adapter may be required. See Lubrication and Maintenance section for wiring schematics.

**NOTE: Control console operates on 12 volt DC only. If two 6 volt batteries are connected in series, make sure power connection provides 12 volt DC across positive terminal on one battery and negative terminal of second battery. ALWAYS make power connection on battery grounded to tractor chassis.**

2. Adjust tractor drawbar 13-17 inches above ground with hitch pin hole directly below PTO shaft center line. Make sure drawbar is in a stationary position.

### WARNING

**Planter hitch may raise uncontrollably during folding/unfolding and can cause death, serious injury, or damage property and equipment. DO NOT fold or unfold planter without planter attached to a tractor. DO NOT unhitch planter from tractor unless fully folded for transport or fully unfolded with planting units lowered to ground.**

3. Back tractor to planter and connect with minimum 1¼" diameter hitch pin. Make sure hitch pin is secured with a locking pin or cotter pin. If tractor is not equipped with a hitch pin locking device.

**NOTE: DO NOT install safety chain using clevis mounting hardware. Safety chain MUST be installed separately.**

4. Safety chain must be used to keep planter and tractor connected in case of a hitch pin/drawbar failure. Attach safety chain at an unused clevis mounting hole on the planter hitch. Torque hardware to 840 ft-lb (1138.8 N-m).



Tractor and safety chain hookup

 **WARNING**

Pressurized hydraulic fluid can penetrate body tissue and result in death, serious infection, or other injuries. Fluid injected under skin must be **IMMEDIATELY** removed by a surgeon familiar with this type of injury. Make sure connections are tight and hoses and fittings are not damaged before applying system pressure. Leaks can be invisible. Keep away from suspected leaks. Relieve pressure before connecting or disconnecting tractor, searching for leaks, or performing any system maintenance.

**NOTICE**

Wipe hose ends to remove any dirt before connecting couplers to tractor ports or contamination may cause equipment failure.

**NOTICE**

Connect hydraulic motor case drain to a case drain return line with zero PSI on tractor. Failure to connect to a return with zero PSI will cause hydraulic motor shaft seal damage. **DO NOT** connect hydraulic motor case drain to a SCV outlet or motor return circuit connection. Contact tractor manufacturer for specific details on “zero pressure return”.

**NOTICE**

Always connect hydraulic motor return hose to tractor motor return port. Do not connect to tractor SCV unless through a motor spool or hydraulic motor failure can occur. If a motor return port is not available on the tractor, the SCV controlling the ASD system **MUST** be in the float position before planter is moved in planting or field raised position when ASD system is not in use.

5. Connect hydraulic hoses to tractor ports in a sequence familiar and comfortable to the operator.

Color and Label	Machine Function	Hose Size	Hose Function
Red AA	Field Lift	1/2"	Pressure
Red BB		1/2"	Return
Blue AA	Planter Fold & Row Marker	3/8"	Return
Blue BB		3/8"	Pressure
Green RR	EdgeVac Vacuum Fan	3/4"	Return
Green PP		1/2"	Pressure
Orange CD		3/8"	Case Drain
Yellow RR	ASD System Pressure Fan	3/4"	Return
Yellow PP		1/2"	Pressure
Orange CD		3/8"	Case Drain

**NOTICE**

Clean and grease PTO shaft coupling with high-pressure industrial coupling grease (Chevron® coupling grease or equivalent) meeting AGMA CG-1 and CG-2 Standards each time driveshaft is installed or premature wear and equipment failure can occur.

**NOTE: A tractor model-specific PTO mount kit is required and available from GnL Engineering (319-227-7222 or gnengineering.net) and Rowe Manufacturing (800-544-4123 or rowemfg.com).**

6. (If applicable) Install PTO pump onto tractor PTO shaft. Make sure shaft rotation matches direction indicated on pump housing.
7. Connect ASABE Standards 7 terminal connector for safety/warning lights on planter to ASABE Standards receptacle on tractor. If your tractor is not equipped with an ASABE Standards receptacle, check with your tractor manufacturer for availability. Check warning lights on planter work in conjunction with warning lights on tractor.

**NOTE: A 12 volt battery connection is required to power the vacuum fan digital gauge. Connect “red” wire to positive (+) battery terminal and “black” wire to negative (-) battery terminal.**

Completely raise parking jack to prevent damage to jack assembly and equipment when moving planter.

**TRANSPORTING PLANTER** **WARNING**

Uncontrolled movement of equipment can cause loss of control and could result in death, serious injury, or damage to property and equipment. Install all safety pins before transporting equipment.

 **WARNING**

Uncontrolled machine movement can crush or cause loss of control resulting in death, serious injury, or damage to property and equipment. Install all safety lockup devices before working under or transporting this equipment.

 **WARNING**

Transporting planter with hoppers over half full or unevenly loaded can cause loss of control and could result in death, serious injury, or damage to property and equipment. Properly load planter when transporting. Be aware of extra transport weight, and road conditions and limits.

Make sure safety/warning lights, reflective decals, and SMV sign are in place and visible before transporting machine on public roads. It is your responsibility to check and comply with all federal, state/provincial, and local regulations.

Be aware of road and bridge weight limits. Allow for additional weight of added options and any additional material or substances that have been added to the machine.

**LEVEL PLANTER**



**Clevis adjustment holes**

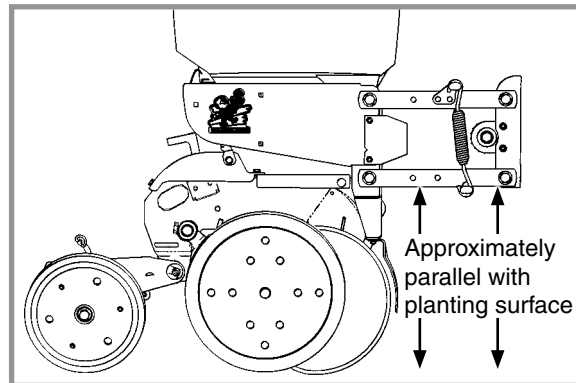

**Level row units**

Toolbar should operate at 20"-22" height from planting surface. Tire pressures must be maintained at pressures specified for planter to operate level laterally. Check toolbar and row unit parallel arms are level front to back with planter lowered to proper operating height.

Five holes in the hitch bracket allow clevis to be raised or lowered. Clevis may be turned over for a finer adjustment between mounting holes. Torque hardware to 840 ft-lb (1138.8 N-m).

Field and actual planting conditions determine which wheel settings to use to ensure row unit parallel arms are approximately parallel with planting surface. If planting in extremely soft soil conditions it may be necessary to move ground drive tires to lower sets of mounting holes. To allow adequate drive force after lowering the ground drive tires, it may be necessary to lower contact drive arms to lower set of holes in wheel module and relocate down pressure springs to lower mounting rod on wheel module.

If planter center is higher or lower than wings after rephasing, contact your Kinze Dealer for valve adjustment or maintenance.

**CONTACT WHEEL SPRING ADJUSTMENT**

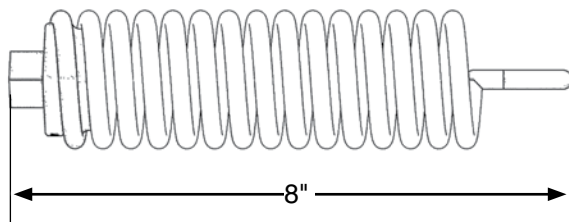

**Spring length measurement (Factory setting)**



**Contact drive springs**

There are two down pressure springs on each contact drive wheel. Spring tension is factory set to approximately 200 lb (90.7 kg) of down force at tire contact point and should require no further adjustment.

**NOTE: Measurement must be taken in planting position with proper tire pressure.**

## CONTACT WHEEL DRIVE SPROCKETS

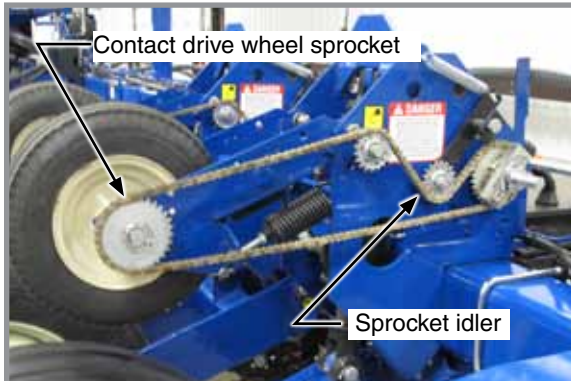

**Contact wheel drive**



**Optional half-rate drive sprocket**

Contact wheel drive works the same for mechanical or EdgeVac planters except for sprocket size. Chain tension is controlled by a spring-loaded sprocket idler. Planting rate charts in “Rate Chart” section help you select correct sprockets.

**NOTE: Make a field test after each sprocket combination change to be sure you are planting at desired rate.**

22 tooth, 28 tooth or 44 tooth sprockets at each contact drive wheel can be exchanged with sprockets on storage rod bolted to wheel module on each side of planter chains. 22 tooth sprockets require 148 pitch No. 40 chains. 28 tooth sprockets require 150 pitch chains. 44 tooth sprockets require use 158 pitch chains.

**NOTE: 22, 28 and 44 tooth drive sprockets do NOT apply to all rate charts. Check chart titles to make sure proper rate chart is selected.**

**NOTE: 54 cell sunflower disc uses 15 tooth drive sprocket at contact wheels and 28 tooth drive sprocket at wheel module reverser plates with 19 tooth sprocket. 15 tooth sprockets require 144 pitch No. 40 chains. Applicable sprockets, chains and instructions supplied in G1K469 Sunflower Rate Reduction Kit.**

Seed planting rate charts are based on standard rate drive. Standard rate drive uses a 30 tooth sprocket and No. 40 118 pitch chain on each contact wheel. Optional half-rate (2 to 1) drive is recommended only when population falls below planting rate charts. Replace 30 tooth sprocket on each contact wheel with a 15 tooth sprocket and shorter No. 40 110 pitch chain. This reduces planter transmission speed and planting and application rates by approximately 50%.

## SEED RATE TRANSMISSION ADJUSTMENT

Planting population rate changes are made using seed rate transmissions at end of each planter wing. Seed rate transmissions allow simple, rapid changes of sprockets by removing lynch pins on hexagon shafts and changing sprockets with those from the sprocket storage rod bolted to transmissions.

Chain tension is controlled by a spring-loaded dual sprocket idler. Idler assembly is adjusted with a easy-release idler arm with a release position to adjust spring tension for planting or remove spring tension for replacing sprockets. See "Wrap Spring Wrench Operation".

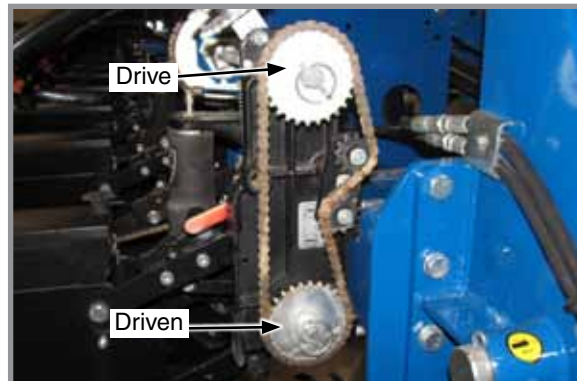

**Seed rate transmission**

A decal on the transmission (behind chain idler) shows proper chain routing. "Rate Charts" section of this manual will help you select correct sprocket combinations.

## WRAP SPRING WRENCH OPERATION

Chain idlers are equipped with wrap spring wrenches. L.H. rotation wrap spring wrenches have a blue release collar and R.H. rotation wrap spring wrenches have a grey or black release collar.



**Wrap spring wrench (L.H. rotation shown)**



**Chain idler tensioning**

Rotate collar on wrap spring wrench and pull handle to release chain tension.

Rotate chain idler into chain and pull handle to tension idler spring.

## SHEAR PROTECTION

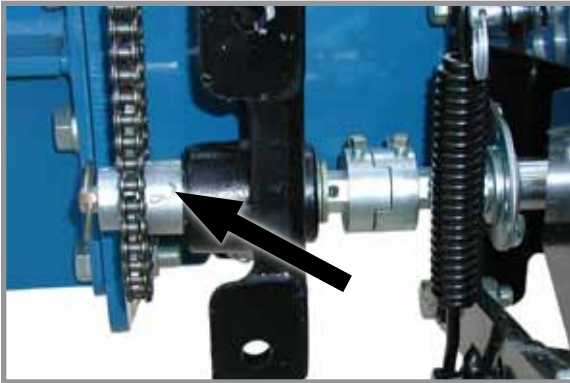

Transmission shaft shear pin



Spare shear pin storage

Planter driveline and seed and granular chemical drivelines are protected from damage by shear pins.

### NOTICE

**Misalignment of drill shaft/transmission coupler alignment will cause equipment damage.**

Determine where binding has occurred if excessive load causes a pin to shear before replacing pin. Replace shear pins with same size and type.

Additional shear pins are in the storage area located at end of each planter wing on inboard side of transport hook.

## SLIDING HITCH LINKAGE



Axle link slide (L.H. shown)

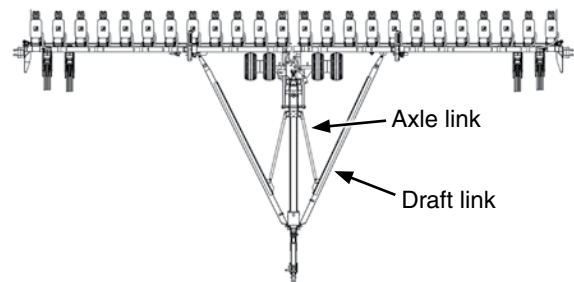

24 Row 30" and 36 Row 20" planters are equipped with sliding axle links which connect R.H. and L.H. draft links to transport axle. Axle links move in a slide on inner side of each draft link when planter folds or unfolds. When axle links reach end of slides, main transport axle is telescoped forward into transport position or rearward into field position.

### NOTICE

**DO NOT GREASE axle link slides or excess dirt accumulation may cause equipment failure. Inspect daily to ensure free movement of axle links in slides. Keep axle link slides clean. Use only powdered graphite if lubrication is desired.**

Stops at either end of slides are designed to allow dirt to escape In normal operating conditions. Under extremely dusty conditions it may be necessary to clean slides.

## HYDRAULIC/ELECTRIC OPERATION

Control console switches and tractor's hydraulic system are used to raise planter to transport position, operate rotate and tongue extension functions, lock and release planter wings, and raise and lower row markers.

**NOTE: Turn console backlighting OFF during extended periods of non-use using push button switch on back of console.**



Single point row clutch control box



Two-speed point row clutch control box

Two dual remote hydraulic outlets (SCV) are required on all sizes of conventional planters equipped with row markers. Three dual remote hydraulic outlets (SCV) are required on all sizes of ASD planters equipped with row markers. One set of outlets is used to operate lift function, one set is used to operate markers, tongue and fold/unfold functions and the third set is used to operate ASD functions (If Applicable).

Marker and point row selector switches are an ON-OFF-ON type. If planter is equipped with optional Two-Speed Point Row Clutch Package, point row switch and reduced rate switch operate independently from rest of control console.

Power to marker switch is fed through auxiliary switch and two transport function switches. Operating any lower row switch disables markers and turns off marker indicator light.

Raise/wing lock and rotate/tongue (fold function) switches are MOMENTARY ON-OFF-MOMENTARY ON type and must be held in position while operating tractor hydraulic SCV control. Activating a fold function switch disables marker circuit.

### WARNING

**Marker selector switch must be OFF (center position) when not in use to prevent accidental extension which could result in death or serious injury, or damage to property and equipment. An indicator light on control box panel is ON whenever marker circuits or point row clutch circuits are energized.**

Auxiliary switch is not used. Keep switch OFF at all times.

**NOTE: Activating auxiliary switch disables all other control console switches except point row clutch switch.**

### DIGITAL VACUUM GAUGE

Digital vacuum gauge control console is equipped with a power toggle switch, run/stop (fans) toggle switch, and two fan speed control toggle switches for the vacuum fans.

Power switch applies power to control console. Run/stop toggle switch turns both fans on when power switch is ON. Fan speed control switches adjusts each fan (left or right).



**Digital vacuum gauge control console**

### PTO PUMP INITIAL STARTUP

1. Fill reservoir with SAE 10W-20 multigrade wide temperature range transmission hydraulic fluid or equivalent.
2. Start system. Allow to run with tractor at idle and fans turned off for 1-2 minutes.
3. Allow to run with tractor at idle and fans at full speed for 1-2 minutes.
4. Check fluid level in reservoir and fill as required.

**NOTE: Fluid level in each tank should be within 1"-2" from top of the tank after pump has run and hydraulic hoses are primed to allow fluid to expand when heated.**

5. Bring tractor to PTO speed and adjust flow control to desired vacuum level using switches on vacuum fan control console.

### ROW UNIT AIR CLUTCHES

Set Air clutch system pressure to 50 psi.

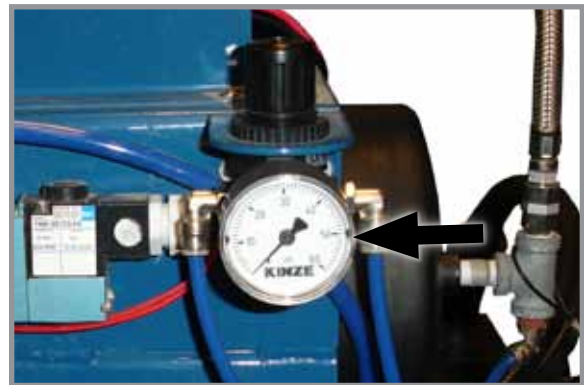

**Air clutch pressure setting**

### HALL EFFECT SENSOR

Set Hall Effect sensor within 1/8" of pick-up disc.

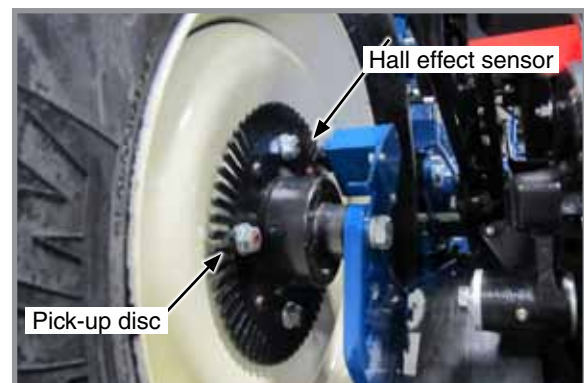

**Hall effect sensor and pick-up disc**

## TRANSPORT TO FIELD SEQUENCE

Position planter in a relatively flat open area without furrows, etc.

### SUMMARIZED TRANSPORT TO FIELD SEQUENCE

1. Remove hitch parallel linkage lock pin or lockup.
2. Lower hitch parallel linkage to release wing hooks.

#### NOTICE

**Unfolding planter without using tractor to assist may cause equipment damage especially in soft conditions or when loaded with seed or fertilizer. Use tractor to reduce stress on frame, drive, and transport components.**

3. Place tractor in reverse and hold in clutch. Start unfolding planter and slowly back up tractor as planter unfolds.
4. Raise planter to remove weight from center (slave) lift cylinder lockups and remove lockups.
5. Lower planter.
6. Remove row marker lockups.
7. Lower catwalk ladder (36 row 20" ASD only)

**NOTE: Read following information for detailed instructions.**

### WARNING

**Planter hitch may raise uncontrollably during folding/unfolding and can cause death, serious injury, or damage property and equipment. DO NOT fold or unfold planter without planter attached to a tractor. DO NOT unhitch planter from tractor unless fully folded for transport or fully unfolded with planting units lowered to ground.**

#### NOTICE

**DO NOT LOWER planter frame onto transport axle in folded transport position or transport tires and row units will be damaged.**

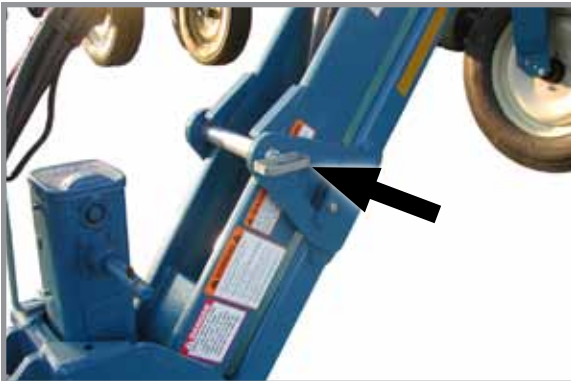

**Hitch parallel linkage pin installed**

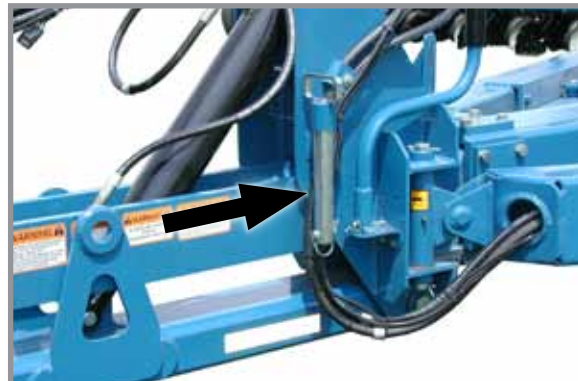

**Hitch parallel linkage pin stored**

1. Fully extend hitch parallel linkage cylinder located on hitch. Remove hitch parallel linkage lock pin from hitch parallel linkage or cylinder lockup from cylinder rod. Store in location provided.

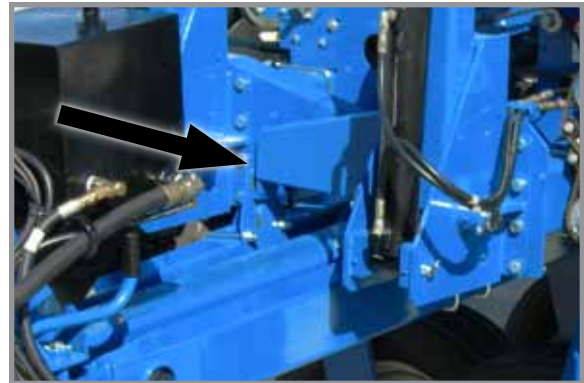
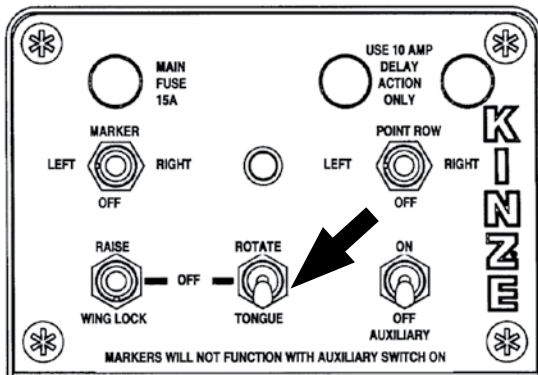

Hitch release from wing hook

2. Hold "ROTATE/TONGUE" switch in "TONGUE" position while operating proper tractor hydraulic control to completely retract hitch parallel linkage cylinder and lower hitch until wing wheels are on ground and hitch has released from hooks on ends of wings.

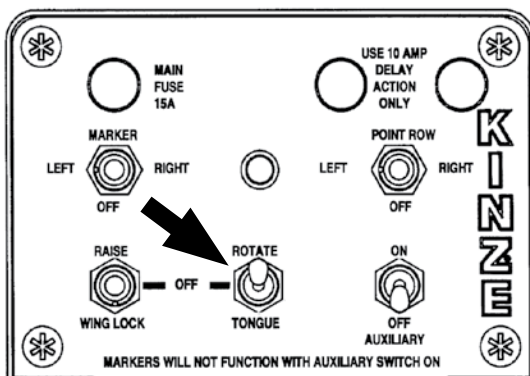

Planter unfolding

#### NOTICE

**Unfolding planter without using tractor to assist may cause equipment damage especially in soft conditions or when loaded with seed or fertilizer. Use tractor to reduce stress on frame, drive, and transport components.**

3. Hold control console ROTATE/TONGUE switch in **ROTATE** and operate hydraulic control to unfold planter. Tongue begins to retract and wings (supported by wing wheels) begin to unfold. Place tractor transmission in a low reverse gear and slowly back up as planter unfolds. Center axle tires should remain stationary and wing tires should roll in a continuous arc with minimal side loading on tires or their mounting structures. Hold switch in "ROTATE" position until tongue cylinder is fully retracted.

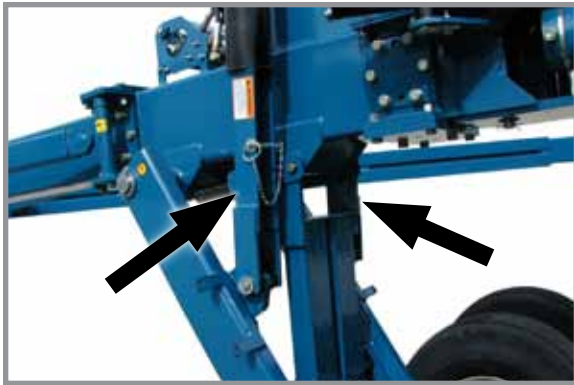

Safety lockups in transport position

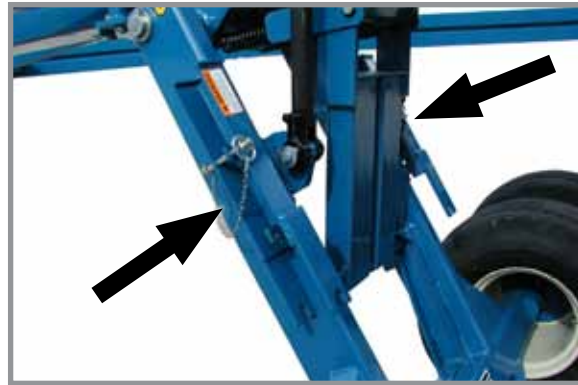

Safety lockups in storage position

**NOTE:** Automatic safety lock will release when planter is raised to remove weight from center lift cylinder lockups. Raising planter too high will reset the mechanism. If this happens, lower machine until hydraulic system stalls against the automatic safety, raise machine slightly to release automatic safety lock and then lower planter.

4. Raise planter to remove weight from center lift (slave) cylinder safety lockups. Remove pins and safety lockups and place in storage location.
5. Lower machine to ground. Center drops until toolbar is level and then entire planter lowers evenly. Hold tractor's hydraulic lever 5 to 10 seconds to rephase system when all lift cylinders are fully retracted.



Lowering planter



Row marker safety lockup installed



Row marker safety lockup stored

6. Remove and store marker lockups.

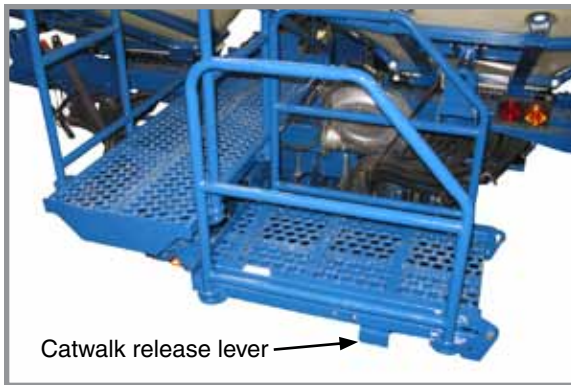

**Catwalk and ladder folded**



**Catwalk and ladder unfolded**

7. (36 Row 20" only) Pull on catwalk release lever and swing catwalk extension out until it locks into position. Lift and swing over ladder.

## FIELD OPERATION

Planters are designed to operate within a speed range of 2 - 8 mph (3 - 13 kph). Higher ground speeds can cause more variation in seed spacing. Speeds above 5.5 mph (8.8 kph) are typically not recommended.

**NOTICE: Always raise planter out of ground when making sharp turns or backing up.**

Normal field planting operation requires use of tractor's hydraulic control to raise and lower planter frame when making field turn arounds. Place hydraulic lever in float position during normal field operation.

**NOTICE: Operate row markers in float position to prevent damage to row markers.**

Operate row markers with control console switch for that marker in ON (LEFT or RIGHT) position and tractor's hydraulic control. After markers are lowered to ground, move hydraulic control to operate markers in float position. Marker speed is controlled with flow control valves located in planter hitch valve block. One valve controls raise speed and other valve controls lower speed of both markers. See "Row Marker Speed Adjustment" and "Row Marker Operation".

## FIELD TO TRANSPORT SEQUENCE

Position planter in a relatively flat open area without furrows, etc.

### SUMMARIZED TRANSPORT TO FIELD SEQUENCE

1. Raise and stow catwalk ladder (36 Row 20" ASD only).
2. Install marker lockups.
3. Raise planter to fully extend master/slave cylinders.
4. Install center (slave) lift cylinder lockups.
5. Lower planter onto center lift cylinder lockups.

#### NOTICE

**Folding planter without using tractor to assist may cause equipment damage especially in soft conditions or when loaded with seed or fertilizer. Use tractor to reduce stress on frame, drive, and transport components.**

6. Place tractor in low forward gear and hold in clutch. Start folding planter and move tractor slowly forward as planter folds to keep wing wheel side pressure to a minimum.
7. Raise hitch parallel linkage to engage wing hooks.
8. Install hitch parallel linkage lock pin or lockup bracket.
9. Lower hitch parallel linkage cylinder.

**NOTE: Read following information for detailed instructions.**

### WARNING

**Planter hitch may raise uncontrollably during folding/unfolding and can cause death, serious injury, or damage property and equipment. DO NOT fold or unfold planter without planter attached to a tractor. DO NOT unhitch planter from tractor unless fully folded for transport or fully unfolded with planting units lowered to ground.**



**Catwalk and ladder unfolded**

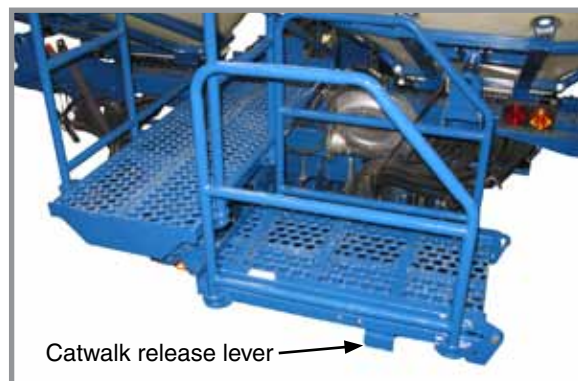

**Catwalk and ladder folded**

1. (36 Row 20" only) Lift and swing over ladder onto top of catwalk extension. Pull on catwalk release lever and swing extension to stored position until it locks into position.



Row marker safety lockup stored

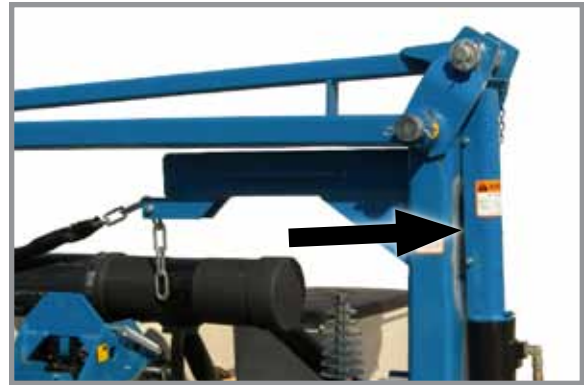

Row marker safety lockup installed

2. Install cylinder lockups on marker cylinders to prevent markers from unfolding when not in use or planter is in transport position.

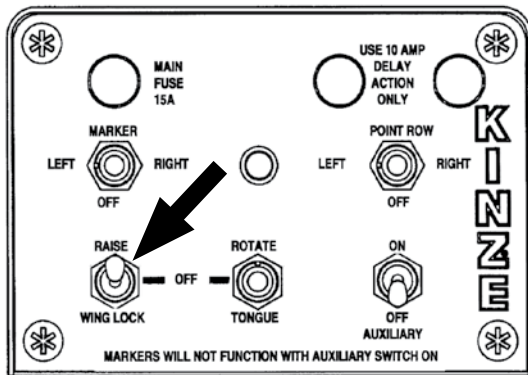

Raising planter

3. Hold RAISE/WING LOCK switch on control console in **RAISE** while operating proper tractor hydraulic control to raise planter. Planter frame should raise level until lift (master) cylinders at ends of wings are fully extended. Center lift (slave) cylinders will continue to extend (at a somewhat slower rate) until they are fully extended.

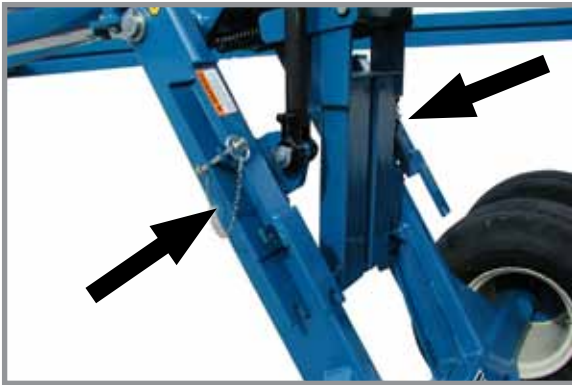

Safety lockups in storage position

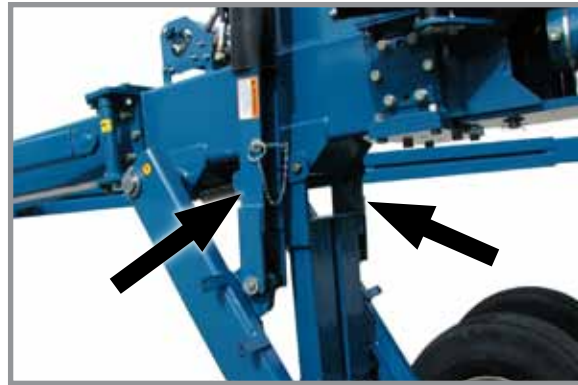

Safety lockups in transport position

**NOTICE**

**DO NOT** fold planter into transport position without lift cylinder lockups installed or uncontrolled planter settling can damage equipment.

4. Install center (slave) lift cylinder lockups. Install pin assembly to lock each in place.
5. Lower planter onto center lift (slave) cylinder lockups.

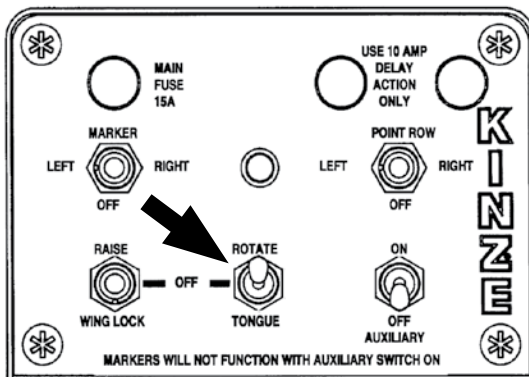

Planter folding

6. Hold ROTATE/TONGUE switch in **ROTATE** and operate hydraulic control to fold planter. Slowly idle tractor forward as you fold planter, allowing center axle tires to remain stationary and wing tires to roll in a continuous arc with minimal side loading on tires or their mounting structure. Hooks on wing ends should pass over planter hitch and contact stops on draft links.

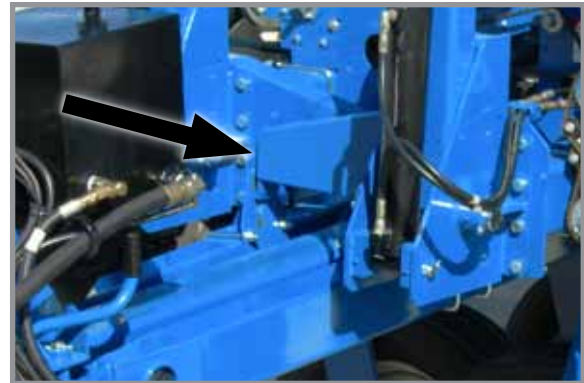
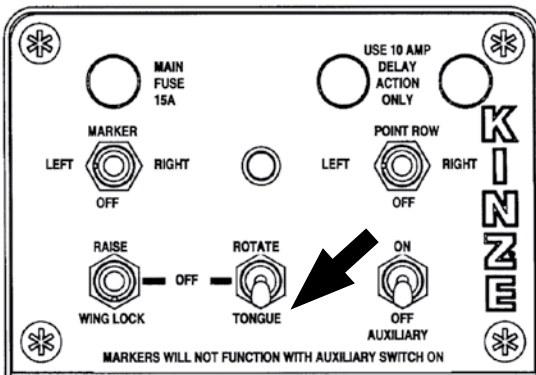

Wing end hook

**NOTICE**

**DO NOT LOWER** planter frame onto transport axle in folded transport position or transport tires and row units will be damaged.

- Raise hitch parallel linkage to completely engage wing hooks and completely lift wing wheels off ground.

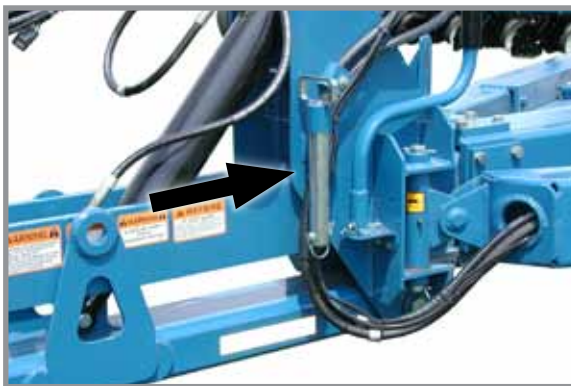

Hitch parallel linkage pin stored



Hitch parallel linkage pin installed

- Install parallel linkage lock pin.
- Lower parallel link cylinder onto lock pin.

## ROW MARKER OPERATION



**DANGER!**

Contacting or coming close to power lines or other high energy sources will cause death or serious injury. Keep away from power lines or high energy sources at all times.



Marker switch

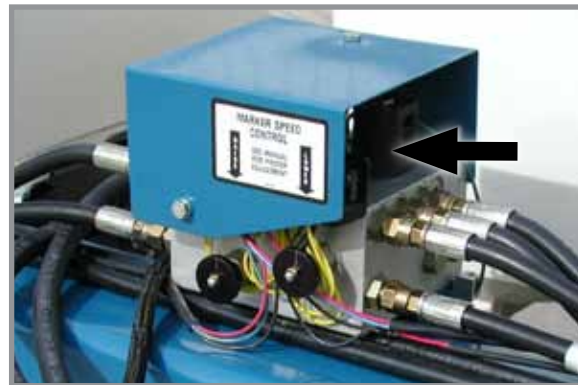

Row marker solenoid valves

Two solenoid valves on valve block at rear R.H. side of center frame, and a three position selector switch on control console permit operator to lower or raise desired row marker.

### NOTICE

Marker position switch must be OFF when planter is not in use or tractor battery will drain.

**NOTE:** See row marker adjustments on following pages.

1. Select which row marker to lower on control console.
2. Operate hydraulic control to lower row marker.
3. Move control switch to other side to operate opposite row marker.
4. Raise row marker at end of field using hydraulic control.
5. After turn, using the hydraulic control, lower the pre-selected row marker.
6. Continue to follow this procedure.

**NOTE:** Both row markers can be lowered by operating switch in each position and hydraulic control twice. Row markers raise simultaneously with hydraulic control in raise position.

If electrical system does not operate properly:

- Check fuse.
- Check wiring connections.
- Check control switch.
- Check solenoid. SOLENOID HOUSING IS MAGNETIZED WHEN ENERGIZED.

## ROW MARKER SPEED ADJUSTMENT

### NOTICE

**Excessive row marker travel speed can damage row markers.  
Adjust flow controls before row markers are first used.**

Marker hydraulic system includes two flow control valves. One flow control valve sets lowering speed and one sets raising speed of both markers. Flow controls determine amount of oil flow restriction through valves, varying marker travel speed.

Loosen jam nut and turn control clockwise, or IN to slow travel speed. Turn counterclockwise, or OUT to increase travel speed. Tighten jam nut after adjustments are complete.

**NOTE: Tractors with flow control valves. Make row marker speed adjustment with tractor flow controls in maximum position. After row marker speed is set, adjust tractor flow controls to allow hydraulic control to stay in detent during marker raise or lower cycle.**

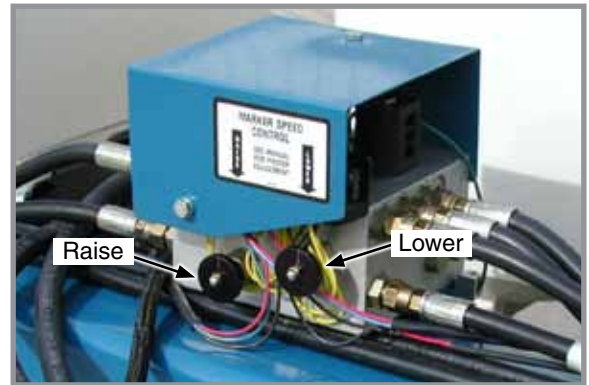

Row marker speed control adjustment

**NOTE: Hydraulics operate slowly when oil is cold. Make all adjustments with oil warm.**

**NOTE: On a tractor where oil flow cannot be controlled, tractor flow rate may be greater than rate marker cylinder can accept. Hold tractor hydraulic control lever until cylinder reaches end of its stroke. This occurs most often on tractors with an open center hydraulic system.**

## ROW MARKER CHAIN ADJUSTMENT

### WARNING

**Uncontrolled marker movement can cause death or serious injury.  
set marker switch OFF and shut off tractor prior to adjustment.**

Chain adjustment is critical. Adjust chain with second stage of marker in vertical position and first stage in horizontal position.

Chain must be adjusted so third stage of marker is pulled out as soon as second stage begins outward travel. Chain stretches with use and needs routine adjustment. It may be necessary to twist chain for a finer adjustment.

Marker chain is PROPERLY ADJUSTED if marker blade pushes dirt 12" or less as marker completes fold into field operating position. Chain should have some slack when marker is in field operating position.

Marker chain is TOO LOOSE and should be adjusted if marker blade pushes dirt more than 12" as it completes the fold into field operating position.

Marker chain is TOO TIGHT if it will not allow marker blade to follow ground contour and chain is tight when marker is in field operating position.

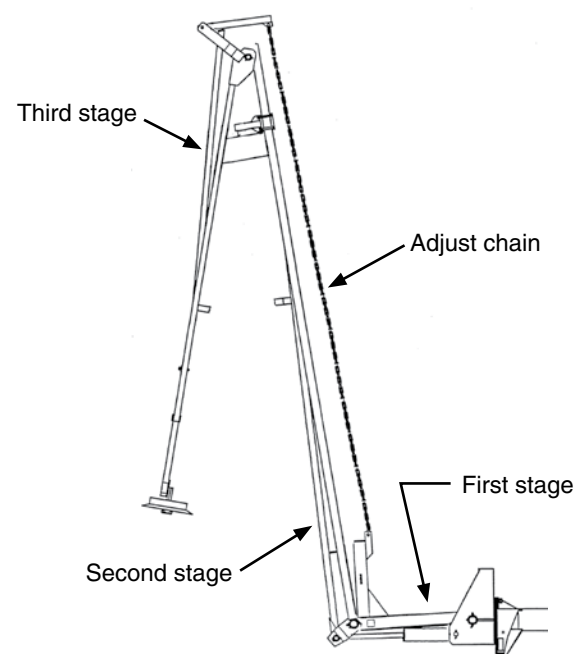

## ROW MARKER LENGTH AND DISC BLADE ADJUSTMENT

1. Multiply number of rows by the average row spacing in inches to determine total planting width.

Row Marker Lengths	
24 Row 20"	480" (1,219.2 cm)
24 Row 30"	720" (1,828.8 cm)
36 Row 20"	720" (1,828.8 cm)

2. Lower planter and row marker assembly to ground.
3. Measure from planter center line to a point where blade contacts ground.
4. Adjust row marker extension so distance from marker disc blade to center line of planter is equal to total planting width. Adjust right and left row marker assemblies equally and securely tighten clamping bolts.

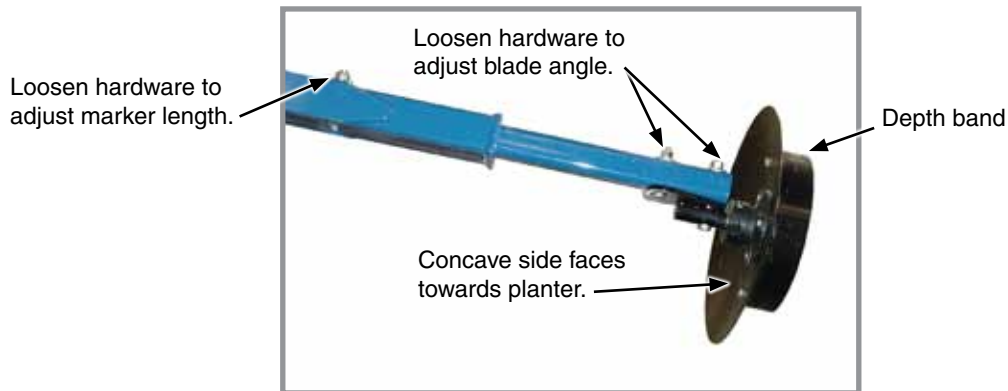

**Row marker disc blade angle adjustment**

### **NOTICE**

**Setting marker disc blade assembly at a sharper angle than needed adds stress to row marker assembly and shortens bearing and blade life. Set blade angle only as needed to leave a clear mark.**

Marker disc blade is installed with concave side facing inward. Spindle assembly is slotted so hub and blade can be angled to throw more or less dirt.

5. Loosen hardware and move assembly as required.
6. Tighten bolts to specified torque.
7. Do a field test to ensure markers are properly adjusted.

**NOTE: A notched marker blade is available from Kinze through your Kinze Dealer for use in more severe no till conditions.**

## EDGEVAC SYSTEM

Kinze EdgeVac seed metering system includes seed meters, seed discs, and an air system consisting of a hydraulic driven vacuum fan which draws air through manifolds, hoses, and seed meters on each row unit.

### WARNING

**Moving fan blades can cause amputation or severe injury. Never operate vacuum fan with cover removed.**

## VACUUM FAN VALVE BLOCK ASSEMBLY

A pressure relief valve prevents build up of oil pressure over 35 PSI in case drain line when vacuum fan motor is operating. This valve vent oils outside through a drain hole in aluminum valve block. This can occur whenever case drain is improperly connected or pressure in motor circuit builds.

Valve block contains a check valve that prevents vacuum fan from operating in wrong direction if pressure is applied to return side of motor and allows fan to coast to a stop when tractor hydraulic control is returned to neutral position.



**Vacuum fan valve block**

See "Hydraulic Schematic (Vacuum Fan System)" in Lubrication and Maintenance section.

**NOTE: Fan turns at a reduced speed if reverse pressure is applied.**

## ANALOG VACUUM OR PRESSURE GAUGE

Analog vacuum or pressure gauge connects directly to EdgeVac (vacuum) or ASD (pressure) manifold and is teed into digital sending units.

Only adjustment is to "zero" needle with no vacuum or pressure present. If there is a significant difference between gauge and a reading taken at meters, a different manifold location should be found to connect hose to gauge and digital sending unit.



**Analog gauge**

**NOTE: Analog gauges are identical EXCEPT for plug and hose barb locations in side of gauge housing. DO NOT connect EdgeVac or ASD hose to wrong gauge. Check plug and hose barb installation if readout is erratic or appears inaccurate.**

**KINZE COBALT SYSTEM**

The Cobalt electronic seed monitor system consists of a tractor-mounted console, seed tubes with computerized sensors installed in each planter row unit, a primary harness connecting console to planter harness, and a planter harness (junction Y-harness and/or harness extension where applicable), connected to each seed tube sensor.

Cobalt monitor is built to withstand harsh environments associated with today’s agricultural industry. The weathertight enclosure seals out dirt and moisture encountered during normal operating conditions

This system is compatible with all Kinze planters, and can be transferred between multiple vehicles to maximize return on investment.

The Cobalt system allows manual control of air clutches and variable population control when planter is equipped with these options. It is not GPS compatible.

**NOTE: See Kinze Cobalt Operator Manual for installation and programming.**



**Kinze Cobalt display**

**AG LEADER INTEGRA DISPLAY**

Integra is a full-featured hub of any precision farming operation. A large, full-color 12.1" HD touchscreen display is easy to read and offers powerful, year-round precision farming tools. Mapping, planter and application control, yield monitoring, real-time data logging, and more – are all controlled from the cab using the Integra display.

Four video camera inputs provide operators a better view of equipment operation and safety by allowing them to view live video on the display.

**NOTE: See Integra Operator Manual for installation and programming.**



**Ag Leader Integra display**

**PLANTER MONITOR MODULE (PMM)**

PMM Magnetic Distance Sensor Package includes a planter-mounted module enclosure with cover and mounting hardware, seed tubes w/sensors, planter harness, planter monitor cable, shaft rotation sensors and magnetic distance sensor components.

Ag Leader Integra display and associated cab harnesses are also required.

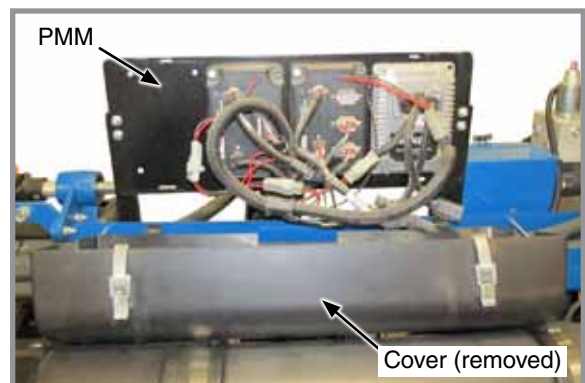

**Planter Monitor Module (PMM)**

## POINT ROW CLUTCHES

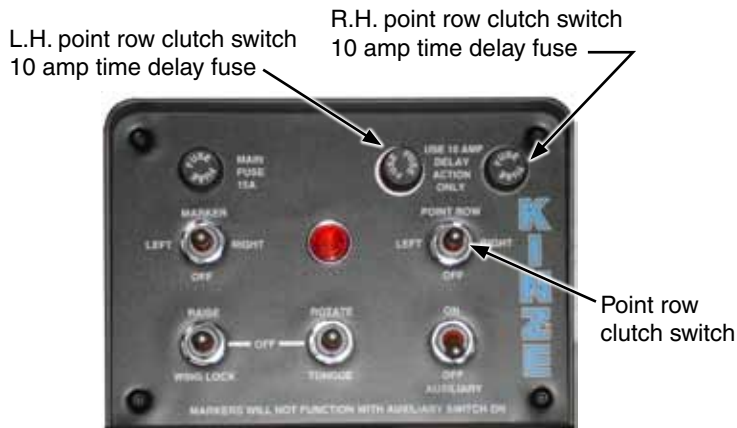

Single point row clutch control box



Point row clutch

Electric-activated clutches disengage drive on either half of planter for finishing up fields or for long point row situations. Clutch selector switch is located on tractor control box.

### NOTICE

**Switch must be OFF when planter is not in use or tractor battery will be drained.**

**NOTE: Liquid fertilizer piston pump has its own drive wheel and is not affected by point row clutch.**

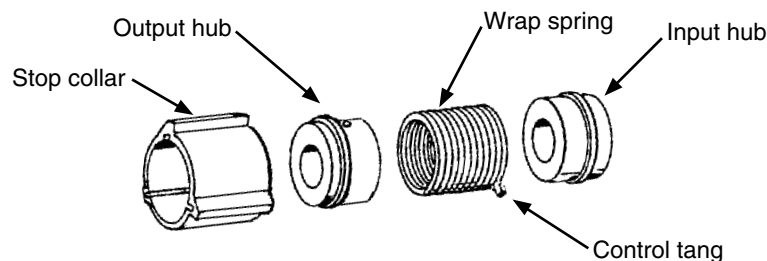

Clutch consists of a wrap spring riding on an input and output hub. Wrap spring is wrapped tightly over hubs during operation locking them together. Higher speeds create a tighter grip of spring on hubs.

Input end of spring is bent outward and is called the control tang. Control tang fits into a slot in stop collar located between input and output hubs over wrap spring. If stop collar is allowed to rotate with input hub, clutch is engaged. If stop collar is stopped from rotating, control tang connected to it is forced back and spring opens. This allows input hub to continue rotating without transmitting torque to output hub, stopping planter drive.

Stop collar is controlled by an electric solenoid and an actuator arm. When selector switch on tractor control box is OFF, solenoid coil is NOT ENERGIZED and actuator arm will not contact stop on stop collar, allowing it to rotate with hubs and drive planter.

When operational switch is in "DISENGAGE" (right or left) solenoid coil IS ENERGIZED and plunger in solenoid coil pulls actuator arm against stop on stop collar, disengaging wrap spring and stopping planter drive.

**TWO-SPEED POINT ROW CLUTCHES**

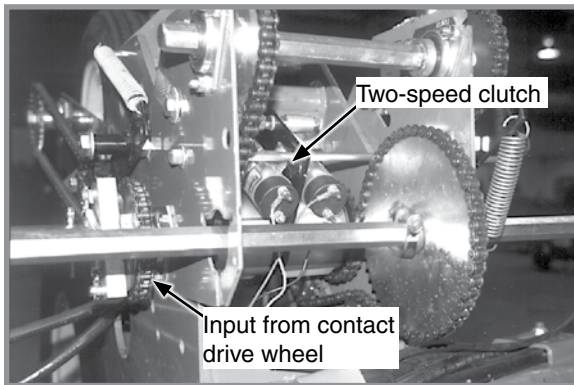

**Two-speed point row clutch**

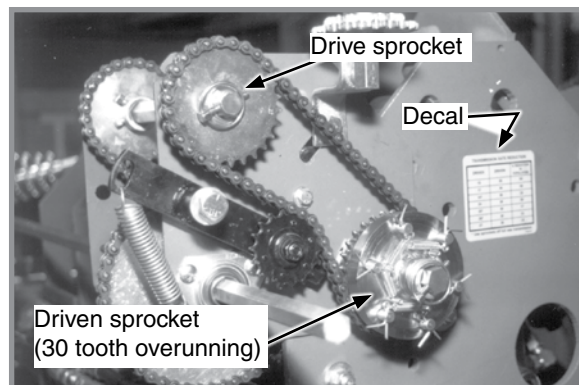

**Two-speed point row clutch driven sprockets**

Optional Two-Speed Point Row Clutch Package allows on-the-go population rate adjustment and capability to shut off either half of planter for finishing up fields or for long point row situations.

Population reduction ratio is determined by sprocket ratio between wheel module extension drive and driven sprockets. A rate reduction decal is located on wheel module extension.

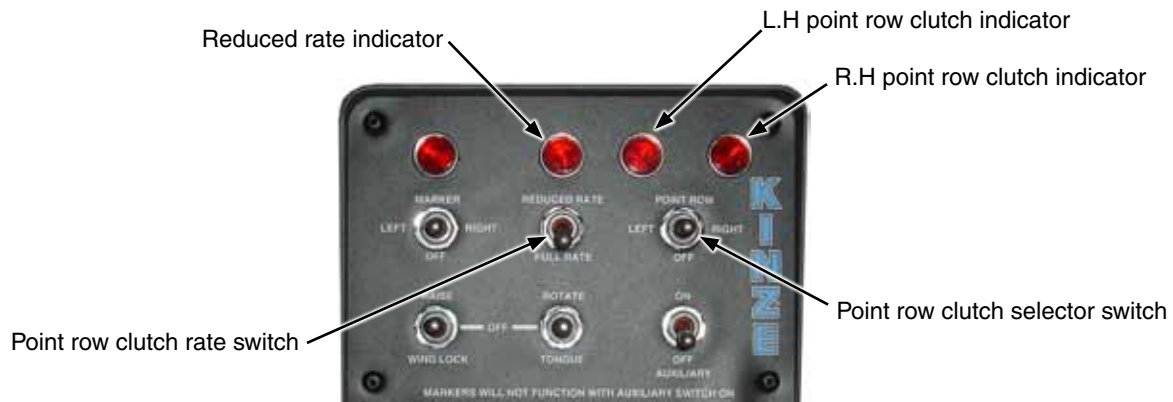

**Two-speed point row clutch control box**

Point row clutches are controlled by control console point row clutch switches. The point row switch shuts off left or right half of planter. Activating reduced rate switch engages one solenoid on each clutch assembly and reduces planting rate for entire planter.

**NOTICE**

**Point row switch must be OFF and rate switch left in FULL RATE when planter is not in use or tractor battery will be drained.**

**NOTE: Liquid fertilizer piston pump has its own drive wheel and is not affected by point row clutch.**

## PISTON PUMP

**NOTE: Keep manuals shipped with pump and flow divider with this manual.**



Piston pump

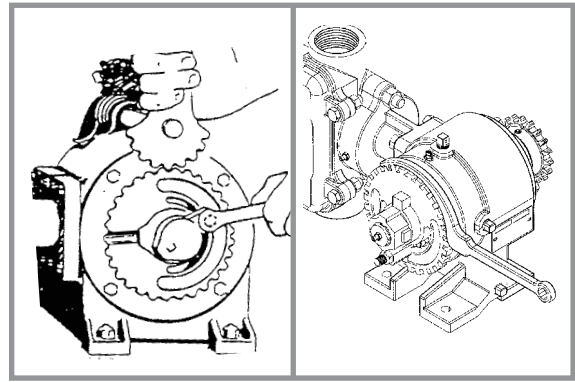

Adjusting delivery rate

**NOTE: Delivery rate chart in Rate Chart section of this manual provides approximate application rate only. Delivery varies with temperature and fertilizer.**

Loosen  $\frac{3}{8}$ " lock nut that secures arm with pointer and rotate scale flange with adjustment wrench until pointer is over desired scale setting. Tighten  $\frac{3}{8}$ " lock nut. **DO NOT OVERTIGHTEN.**

**NOTE: Periodically check flow to all rows. Set rate is delivered to remaining rows if one or more lines are plugged.**

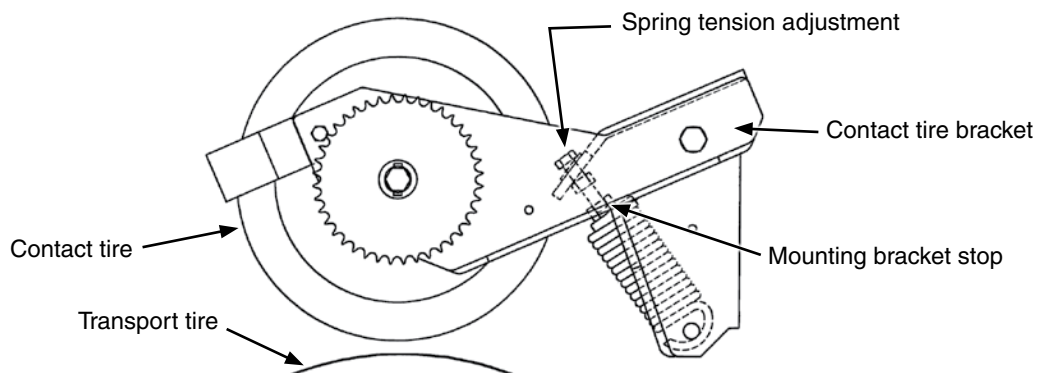

Set piston pump drive spring tension so there is no slack in springs when contact tire bracket is resting on mounting bracket stop. Contact tire and transport tire should not be touching.

## CLEANING

Clean tanks, hoses, and metering pump thoroughly with water at end of planting season or prior to an extended period of non-use. Do not allow fertilizer to crystallize from cold temperature or evaporation.

On machines equipped with piston pump, take apart and clean strainer located between piston pump and ball valve daily. Remove the end cap to clean the screen. See Piston Pump Storage in Maintenance Section of this manual.

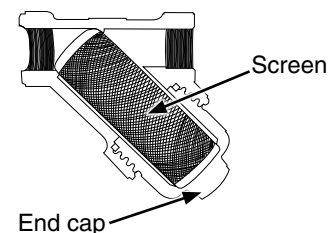

## CHECK VALVES



Old style non-reparable check valve



New style reparable check valve

Optional low rate check valves are available for in-line installation between liquid fertilizer piston pump and openers to ensure equal distribution of product at low rates. Check valves eliminate anti-siphon loops.

## REAR TRAILER HITCH (24 ROW 30" ONLY)



Trailer hitch



Hitch position during lift

Rear trailer hitch is used to tow a 3 or 4 wheel wagon behind planter. Hitch height during field operation and transport is 15". Hitch height will raise to approximately 42" when planter is lifted.

### NOTICE

Rear trailer hitch is designed for use with piston pump only. Maximum allowable hitch weight is 200 lb (90.71 kg). Do not exceed 6,000 lb (2,721.55 kg) gross towing weight or the equivalent of a loaded 500 gal (1,892.7 L) tank and running gear or equipment can be damaged.

**NOTE:** Periodically check feed hose for kinks to prevent restricted delivery rate.

Adjust rear trailer hitch length by loosening the 5/8" set screws at rear of outer tube, removing 1" x 8 1/2" bolt at center of hitch, and sliding hitch in or out to one of 4 sets of adjustment holes. Reinstall and tighten hardware.

## FIELD TEST

Perform a field test with any change of field and/or planting conditions, seed size or planter adjustment to ensure proper seed placement and operation of row units.

- Check planter for front to rear and lateral level operation. See "Level Planter".
- Check **all** row units to be certain they are running level. Row unit parallel arms should be approximately parallel to the ground when planting.
- Check row markers for proper operation and adjustment. See "Row Marker Speed Adjustment", "Row Marker Chain Adjustment", and "Row Marker Length and Disc Blade Adjustment".
- Check for proper application rates and placement of granular chemicals on **all** rows. See "Field Check Granular Chemical Application".
- Check for desired depth placement and seed population on **all** rows. See "Field Check Seed Population".
- Check for proper application rates of fertilizer on **all** rows. See "Fertilizer Application Rate Chart".

Reinspect machine after field testing.

- Hoses And Fittings
- Bolts And Nuts
- Cotter Pins And Spring Pins
- Drive Chain Alignment

## FIELD CHECK SEED POPULATION

1. Tie up one or more sets of closing wheels by running a chain or rubber tarp strap between the hopper support panel and closing wheels. It may be necessary to decrease closing wheel arm spring tension.

Chain, rubber tarp strap, or similar.

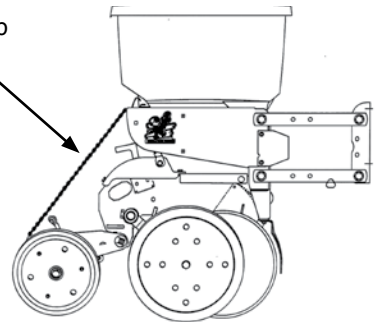

2. Plant a short distance and check to see if seed is visible in the seed trench. Adjust planting depth to a shallower setting if seed is not visible and recheck.

Planting depth adjustment handle

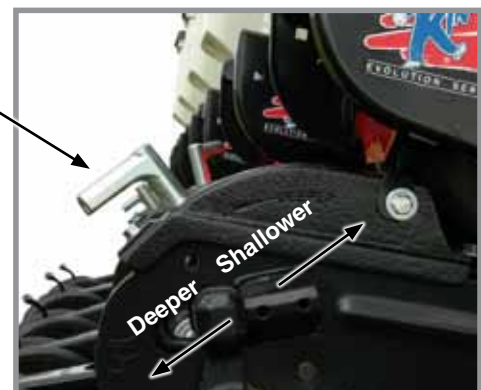

Planting depth adjustment

3. Measure  $\frac{1}{1000}$  of an acre. See chart for correct distance for row width being planted. For example, if planting 30" rows  $\frac{1}{1000}$  of an acre would be 17' 5".

$\frac{1}{1000}$ Acre Seed Population Count Row Width/Distance		
Row Width	20"	30"
Distance	26'2"	17'5"

**NOTE: Seeds may bounce or roll when planting with closing wheels raised and planting depth set shallow affecting seed spacing accuracy.**

4. Count seeds in measured distance.
5. Multiply number of seeds placed in  $\frac{1}{1000}$  of an acre by 1000. This gives total population.

EXAMPLE: 30" row spacing 17' 5" equals  $\frac{1}{1000}$  acre.  
 26 seeds counted x 1000 = 26,000 seeds per acre

Seed count can be affected by drive wheel and seed meter drive ratio, tire pressure, and/or seed meter malfunction.

1. If seed check shows average distance between seeds in inches is significantly different than seed rate chart indicates, first check drive ratio between drive wheel and seed meter. Check drive wheel air pressure, check for incorrect sprocket(s) in driveline and check drive and driven sprockets on transmission(s) for proper selection.
2. Check for seed meter malfunction. For example, if spacing between kernels of corn at the transmission setting being used is 8" and a gap of 16" is observed, a finger has lost its seed and not functioned properly. If two seeds are found within a short distance of each other, finger has metered two seeds instead of one.
3. See "Seed Meter (Finger Pickup) Troubleshooting" or "Seed Meter (Brush-Type) Troubleshooting" in Troubleshooting Section of this manual.

### DETERMINING POUNDS PER ACRE (BRUSH-TYPE METER)

Seeds per acre ÷ Seeds per pound (from label) = Pounds per acre

If seeds per pound information is not available use the following averages:

- 2,600 seeds per pound for medium size soybeans
- 15,000 seeds per pound for medium size milo/grain sorghum
- 4,500 seeds per pound for medium size cotton

### DETERMINING BUSHELS PER ACRE

Pounds per acre ÷ Seed unit weight = Bushels per acre

Average Unit Weight of:

- 1 Bushel Soybeans = 60 Pounds
- 1 Bushel Milo/Grain Sorghum = 56 Pounds
- 1 Bushel Cotton = 32 Pounds

If seed population check shows planting rate is significantly different than seed rate chart shows or if a particular meter is not planting accurately, see "Brush-Type Seed Meter Maintenance" and "Seed Meter (Brush-Type) Troubleshooting".

## FIELD CHECK GRANULAR CHEMICAL APPLICATION

Temperature, humidity, speed, ground conditions, flowability of different material, or meter obstructions can affect granular chemical rate of delivery.

### WARNING

**Agricultural chemicals can cause death or serious injury to persons, animals, and plants or seriously damage soil, equipment, or property. Read and follow all chemical and equipment manufacturers labels and instructions.**

Perform a field check to determine application rates.

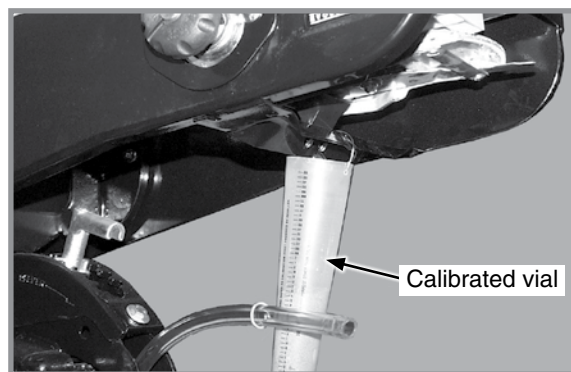

**Granular chemical field check**

1. Fill insecticide and/or herbicide hoppers.
2. Attach a calibrated vial to each granular chemical meter.

**NOTE: Disengage clutch to avoid dropping seed during test.**

3. Lower planter and drive 1320 feet at planting speed.
4. Weigh chemical in ounces caught in one vial.
5. Multiply that amount by factor shown to determine pounds per acre.

Pounds Per Acre	
Row Width	Factor
20"	1.25
30"	.83

**EXAMPLE:** You are planting 30" rows. You have planted for 1320 feet at desired planting speed. You caught 12.0 ounces of chemical in one vial. 12.0 ounces times 0.83 equals 9.96 pounds per acre.

**NOTE: Check calibration of all rows.**

### METERING GATE

Use metering gate setting as a starting point for distributing insecticide or herbicide. Charts are based on 5 mph (8 kph) planting speed. Use a higher gate setting for speeds faster than 5 mph (8 kph) and a lower setting for speeds slower than 5 mph (8 kph).

**This page intentionally left blank.**

## GENERAL PLANTING RATE INFORMATION

These planting rate charts apply to KINZE Model 3700 planters.

### **NOTICE**

**Sprocket combinations in these charts are for average conditions. Changes in sprocket combinations may be required for desired planting population. ALWAYS MAKE FIELD CHECKS TO BE SURE YOU ARE PLANTING AT DESIRED RATE.**

### **NOTICE**

**Seed additives added in the hopper may affect finger pickup seed meter performance and accelerate wear.**

**NOTE: Seed size and shape may affect planting rate.**

**NOTE: Not all row spacings listed apply to all size planters.**

**NOTE: Speeds above 5.5 MPH (8.8 KPH) can adversely affect seed spacing.**

## MECHANICAL

### Finger Pickup Corn Meter

Larger grades generally plant more accurately at the high end of the ground speed range than smaller grades. Higher than optimum speeds may result in population rate increase or higher incidence of doubles, particularly with small seed. Medium round corn seed is most desirable for planting accuracy at optimum speed.

### Finger Pickup Oil Sunflower Meter

Larger grades generally plant more accurately at the high end of the ground speed range than smaller grades. Higher than optimum speeds may result in population rate increase or higher incidence of doubles, particularly with small seed. No. 3 and/or No. 4 size oil sunflower seeds are recommended for use in finger pickup seed meters equipped with oil sunflower fingers. No. 1 and/or No. 2 size confectionery sunflower seeds are recommended for use in finger pickup seed meters equipped with corn fingers.

### Brush-Type Seed Meter (Soybean, Milo/Grain Sorghum, Acid-Delinted Cotton)

Rate charts are given in seeds per acre as well as seed spacing in inches rounded to nearest tenth of an inch. Because of large range in seed size, pounds per acre is not a suggested method of selecting transmission settings. Smaller size seed pounds per acre may be below what was expected and large seed pounds per acre may appear above expectations. To determine pounds per acre, use formula given in "Determining Pounds Per Acre (Brush-Type Seed Meter)" in "Check Seed Population" in Machine Operation section of this manual.

**NOTE: Planting speed can affect actual seeding rate. Make a field check and adjust transmission setting to obtain desired seed drop.**

**NOTE: Seed population per acre with 15" rows double rate for 30" rows, as well as 18" rows versus 36" rows and 19" rows versus 38" rows, at listed sprocket combination. See following pages.**

**NOTE: Half Rate (2 to 1) Drive Reduction Package may be required to obtain desired population and seed spacing when planting 15" row soybeans or other crops. Half Rate Drive with brush-type seed meters reduces planter transmission speed. Seeding rate will be approximately 50% of chart reading when using Half Rate (2 To 1) Drive Reduction Package.**

**EXAMPLE: 30" row spacing using 60 cell seed discs in brush-type seed meters.  
 $80,928 \div 2 = 40,464$  Population (2.6" Seed Spacing x 2 = 5.2" Seed Spacing)**

## EDGEVAC

**NOTE: 22, 28 and 44 tooth drive sprockets are NOT applicable to all rate charts. Check chart titles to ensure proper rate chart is selected. 22 tooth sprockets require use of 148 pitch No. 40 chains, 28 tooth sprockets require use of 150 pitch No. 40 chains and 44 tooth sprockets require use of 158 pitch No. 40 chains.**

**NOTE: When using 54 cell sunflower disc, use 15 tooth drive sprocket at contact wheels and replace 28 tooth drive sprocket at wheel module reverser plates with 19 tooth sprocket. 15 tooth sprockets require use of 144 pitch No. 40 chains. Applicable sprockets, chains, and instructions supplied in G1K469 Sunflower Rate Reduction Kit.**

**PLANTING RATES FOR FINGER PICKUP SEED METERS (STANDARD DRIVE)  
APPROXIMATE SEEDS/ACRE FOR VARIOUS ROW WIDTHS**

20" Rows	30" Rows	Transmission Sprockets		Recommended Speed Range (MPH)	Average Seed Spacing In Inches
		Drive	Driven		
24,279	16,186	17	28	4 to 6	12.9
25,178	16,785	17	27	4 to 6	12.5
26,147	17,431	17	26	4 to 6	12.0
27,135	18,090	19	28	4 to 6	11.6
27,192	18,128	17	25	4 to 6	11.5
28,140	18,760	19	27	4 to 6	11.1
28,325	18,883	17	24	4 to 6	11.1
29,222	19,481	19	26	4 to 6	10.7
29,556	19,704	17	23	4 to 6	10.6
30,392	20,261	19	25	4 to 6	10.3
31,656	21,104	19	24	4 to 6	9.9
32,847	21,898	23	28	4 to 6	9.5
33,033	22,022	19	23	4 to 6	9.5
34,064	22,709	23	27	4 to 6	9.2
34,275	22,850	24	28	4 to 6	9.2
35,375	23,583	23	26	4 to 6	8.9
35,546	23,697	24	27	4 to 6	8.8
35,703	23,802	25	28	4 to 6	8.8
35,780	23,853	17	19	4 to 6	8.8
36,789	24,526	23	25	4 to 6	8.5
36,912	24,608	24	26	4 to 6	8.5
37,026	24,684	25	27	4 to 6	8.5
37,133	24,755	26	28	4 to 6	8.4
38,322	25,548	23	24	4 to 6	8.2
38,388	25,592	24	25	4 to 6	8.2
38,450	25,633	25	26	4 to 6	8.2
38,507	25,671	26	27	4 to 6	8.1
38,561	25,707	27	28	4 to 6	8.1
39,989	26,659	23	23	4 to 6	7.8
41,469	27,646	28	27	4 to 6	7.6
41,526	27,684	27	26	4 to 6	7.6
41,655	27,770	25	24	4 to 6	7.5
41,727	27,818	24	23	4 to 6	7.5
43,064	28,709	28	26	4 to 6	7.3
43,187	28,791	27	25	4 to 6	7.3
43,466	28,977	25	23	4 to 6	7.2
44,693	29,795	19	17	4 to 6	7.0
44,787	29,858	28	25	4 to 6	7.0
44,987	29,991	27	24	4 to 6	7.0
45,204	30,136	26	23	4 to 6	7.0
46,653	31,102	28	24	3 to 6	6.7
46,943	31,295	27	23	3 to 6	6.7
48,407	32,271	23	19	3 to 5.5	6.5
48,681	32,454	28	23	3 to 5.5	6.5
50,511	33,674	24	19	3 to 5.5	6.2
52,616	35,077	25	19	3 to 5	6.0
54,102	36,068	23	17	3 to 5	5.8
54,720	36,480	26	19	3 to 5	5.7
56,454	37,636	24	17	3 to 5	5.6
56,825	37,883	27	19	3 to 5	5.5
58,806	39,204	25	17	3 to 4.5	5.3
58,931	39,287	28	19	3 to 4.5	5.3
61,158	40,772	26	17	3 to 4.5	5.1
63,510	42,340	27	17	3 to 4.5	4.9
65,862	43,908	28	17	3 to 4.5	4.8

**NOTE: See "General Planting Rate Information" and "Check Seed Population" pages for more information. Always field check seed population to verify planting rates.**

**PLANTING RATES FOR BRUSH-TYPE SEED METERS (STANDARD DRIVE)  
APPROXIMATE SEEDS/ACRE FOR VARIOUS ROW WIDTHS**

Transmission Sprockets		60 Cell Soybean Or High-Rate Milo/Grain Sorghum		Average Seed Spacing In Inches	48 Cell Specialty Soybean Or High-Rate Acid-Delinted Cotton		Average Seed Spacing In Inches	Speed Range (MPH)
Drive	Driven	20" Rows	30" Rows		20" Rows	30" Rows		
17	28	121,392	80,928	2.6	97,113	64,742	3.2	2 to 8
17	27	125,889	83,926	2.5	100,712	67,141	3.1	2 to 8
17	26	130,731	87,154	2.4	104,712	69,723	3.0	2 to 8
19	28	135,674	90,449	2.3	108,539	72,359	2.9	2 to 8
19	27	140,699	93,799	2.2	112,559	75,039	2.8	2 to 8
17	24	141,624	94,416	2.2	113,300	75,533	2.8	2 to 8
17	23	147,782	98,521	2.1	118,226	78,817	2.7	2 to 8
19	25	151,955	101,303	2.1	121,563	81,042	2.6	2 to 8
19	24	158,286	105,524	2.0	126,629	84,419	2.5	2 to 8
23	28	164,237	109,491	1.9	131,390	87,593	2.4	2 to 8
19	23	165,168	110,112	1.9	132,135	88,090	2.4	2 to 8
24	28	171,379	114,252	1.8	137,103	91,402	2.3	2 to 8
24	27	177,725	118,483	1.8	142,179	94,786	2.2	2 to 8
17	19	178,895	119,263	1.8	143,115	95,410	2.2	2 to 8
24	26	184,560	123,040	1.7	147,648	98,432	2.1	2 to 8
26	28	185,660	123,773	1.7	148,527	99,018	2.1	2 to 8
24	25	191,943	127,962	1.6	153,555		2.0	2 to 8
26	27	192,536	128,357	1.6	154,029		2.0	2 to 8
23	23	199,941	133,294	1.6	159,953		2.0	2 to 8
27	26	207,630	138,420	1.5	166,104		1.9	2 to 8
24	23	208,634	139,089	1.5	166,907		1.9	2 to 8
25	23	217,326	144,884	1.4	173,861		1.8	2 to 8
19	17	223,463	148,975	1.4	178,770		1.8	2 to 8
27	24	224,933	149,955	1.4	179,946		1.7	2 to 8
28	24	233,264	155,509	1.3	186,661		1.7	2 to 8
23	19	242,033	161,355	1.3	193,626		1.6	2 to 8
28	23	243,405	162,270	1.3	194,724		1.6	2 to 8
24	19	252,557	168,371	1.2	202,044		1.6	2 to 8
25	19	263,079	175,386	1.2	210,464		1.5	2 to 8
23	17	270,507	180,338	1.2	216,405		1.5	2 to 8
26	19	273,603	182,402	1.1	218,883		1.4	2 to 7
27	19	284,126	189,417	1.1	227,301		1.4	2 to 7
28	19	294,650	196,433	1.1	235,719		1.3	2 to 7
26	17	305,792	203,861	1.0	244,634		1.3	2 to 7
27	17	317,553	211,702	0.9	245,043		1.2	2 to 7
28	17	329,313	219,542	0.9	263,451		1.2	2 to 7

**NOTE:** See "General Planting Rate Information" and "Check Seed Population" pages for additional information.

**NOTE:** When using Half Rate (2 To 1) Drive Reduction Package, rates are approximately 50% of given numbers.

**NOTE:** Always field check seed population to ensure planting rates are correct.

**PLANTING RATES FOR BRUSH-TYPE SEED METERS (STANDARD DRIVE)  
APPROXIMATE SEEDS/ACRE FOR VARIOUS ROW WIDTHS**

Transmission Sprockets		36 Cell Acid-Delinted Large Cotton		Average Seed Spacing In Inches	30 Cell Milo/Grain Sorghum Or Acid-Delinted Cotton		Average Seed Spacing In Inches	Speed Range (MPH)
Drive	Driven	20" Rows	30" Rows		20" Rows	30" Rows		
17	28	72,836	48,557	4.3	60,696	40,464	5.2	2 to 8
17	27	75,534	50,356	4.2	62,945	41,963	5.0	2 to 8
17	26	78,438	52,292	4.0	65,366	43,577	4.8	2 to 8
19	28	81,404	54,269	3.9	67,838	45,225	4.6	2 to 8
19	27	84,419	56,279	3.7	70,350	46,900	4.5	2 to 8
17	24	84,975	56,650	3.7	70,812	47,208	4.4	2 to 8
17	23	88,670	59,113	3.5	73,892	49,261	4.2	2 to 8
19	25	91,173	60,782	3.4	75,978	50,652	4.1	2 to 8
19	24	94,971	63,314	3.3	79,143	52,762	4.0	2 to 8
23	28	98,543	65,695	3.2	82,119	54,746	3.8	2 to 8
19	23	99,101	66,067	3.2	82,584	55,056	3.8	2 to 8
24	28	102,827	68,551	3.0	85,689	57,126	3.7	2 to 8
24	27	106,635	71,090	2.9	88,863	59,242	3.5	2 to 8
17	19	107,337	71,558	2.9	89,447	59,631	3.5	2 to 8
24	26	110,736	73,824	2.8	92,280	61,520	3.4	2 to 8
26	28	111,396	74,264	2.8	92,829	61,886	3.4	2 to 8
24	25	115,158	76,772	2.7	95,972	63,981	3.3	2 to 8
26	27	115,521	77,014	2.7	96,267	64,178	3.3	2 to 8
23	23	119,964	79,976	2.6	99,971	66,647	3.1	2 to 8
27	26	124,578	83,052	2.5	103,815	69,210	3.0	2 to 8
24	23	125,180	83,453	2.5	104,316	69,544	3.0	2 to 8
25	23	130,395	86,930	2.4	108,663	72,442	2.9	2 to 8
19	17	134,078	89,385	2.3	111,732	74,488	2.8	2 to 8
27	24	134,960	89,973	2.3	112,467	74,978	2.8	2 to 8
28	24	139,958	93,305	2.2	116,633	77,755	2.7	2 to 8
23	19	145,220	96,813	2.2	121,017	80,678	2.6	2 to 8
28	23	146,043	97,362	2.1	121,703	81,135	2.6	2 to 8
24	19	151,535	101,023	2.1	126,278	84,185	2.5	2 to 8
25	19	157,848	105,232	2.0	131,540	87,693	2.4	2 to 8
23	17	162,350	108,233	1.9	135,254	90,169	2.3	2 to 8
26	19	164,162	109,441	1.9	136,802	91,201	2.3	2 to 7
27	19	170,475	113,650	1.8	142,064	94,709	2.2	2 to 7
28	19	176,790	117,860	1.8	147,324	98,216	2.1	2 to 7
26	17	183,476	122,317	1.7	152,895	101,930	2.1	2 to 7
27	17	190,532	127,021	1.6	158,777	105,851	2.0	2 to 7
28	17	197,588	131,725	1.6	164,657	109,771	1.9	2 to 7

**NOTE:** See "General Planting Rate Information" and "Check Seed Population" pages for additional information.

**NOTE:** When using Half Rate (2 To 1) Drive Reduction Package, rates are approximately 50% of given numbers.

**NOTE:** Always field check seed population to ensure planting rates are correct.

**PLANTING RATES FOR BRUSH-TYPE SEED METERS (STANDARD DRIVE)  
APPROXIMATE HILLS/ACRE FOR VARIOUS ROW WIDTHS**

Due to variations in cotton seed size, meters equipped with the 12 cell acid-delinted hill-drop cotton discs will plant from 3 to 6 seeds per cell. Select proper disc for seed size range to be planted.

To determine planter transmission setting, determine desired hill spacing and select the transmission ratio closest to the hill spacing in inches on the chart. To decrease population increase spacing. To increase population decrease spacing.

To determine population per acre, determine average seeds per hill and hills per acre by doing a field check. Measure  $\frac{1}{1000}$  of an acre ( $\frac{1}{1000}$  acre = Length of row 17' 5" for 30" row width, 23' 9" for 22" row width and 26' 2" for 20" row width). Multiply average seeds per hill by hills per acre. EXAMPLE: 4 seeds per hill x (13 hills x 1000) = 52,000

Transmission Sprockets		NUMBER OF HILLS PER ACRE 12 Cell Hill-Drop Cotton, Acid-Delinted		Average Hill Spacing In Inches	Speed Range (MPH)
Drive	Drive	20" Rows	30" Rows		
17	28	24,279	16,186	12.9	2 to 8
17	27	25,178	16,785	12.5	2 to 8
17	26	26,147	17,431	12.0	2 to 8
19	28	27,135	18,090	11.6	2 to 8
19	27	28,140	18,760	11.1	2 to 8
17	24	28,325	18,883	11.1	2 to 8
17	23	29,556	19,704	10.6	2 to 8
19	25	30,392	20,261	10.3	2 to 8
19	24	31,658	21,105	9.9	2 to 8
23	28	32,847	21,898	9.5	2 to 8
19	23	33,033	22,022	9.5	2 to 8
24	28	34,275	22,850	9.2	2 to 8
24	27	35,546	23,697	8.8	2 to 8
17	19	35,780	23,853	8.8	2 to 8
24	26	36,912	24,608	8.5	2 to 8
26	28	37,133	24,755	8.4	2 to 8
24	25	38,388	25,592	8.2	2 to 8
26	27	38,507	25,671	8.1	2 to 8
23	23	39,989	26,659	7.8	2 to 8
27	26	41,526	27,684	7.6	2 to 8
24	23	41,727	27,818	7.5	2 to 8
25	23	43,466	28,977	7.2	2 to 8
19	17	44,693	29,795	7.0	2 to 8
27	24	44,987	29,991	7.0	2 to 8
28	24	46,653	31,102	6.7	2 to 8
23	19	48,407	32,271	6.5	2 to 8
28	23	48,681	32,454	6.5	2 to 8
24	19	50,511	33,674	6.2	2 to 8
25	19	52,616	35,077	6.0	2 to 8
23	17	54,102	36,068	5.8	2 to 8
26	19	54,720	36,480	5.7	2 to 7
27	19	56,825	37,883	5.5	2 to 7
28	19	58,931	39,287	5.3	2 to 7
26	17	61,158	40,772	5.1	2 to 7
27	17	63,510	42,340	4.9	2 to 7
28	17	65,862	43,908	4.8	2 to 7

**NOTE:** See "General Planting Rate Information" and "Check Seed Population" pages for additional information.

**NOTE:** When using Half Rate (2 To 1) Drive Reduction Package, rates are approximately 50% of given numbers.

**NOTE:** Always field check seed population to ensure planting rates are correct.

**EDGEVAC PLANTING RATES FOR CORN / POPCORN 39 CELL DISC  
22 TOOTH CONTACT WHEEL DRIVE SPROCKET  
APPROXIMATE SEEDS / ACRE FOR VARIOUS ROW WIDTHS**

30" Rows	Transmission Sprockets		Recomm. Speed Range (MPH)	Average Seed Spacing In Inches
	Drive	Driven		
23,209	15	28	4 to 6	9.0
24,068	15	27	4 to 6	8.7
24,994	15	26	4 to 6	8.4
25,994	15	25	4 to 6	8.0
26,303	17	28	4 to 6	7.9
27,077	15	24	4 to 6	7.7
27,277	17	27	4 to 6	7.7
28,254	15	23	4 to 6	7.4
28,326	17	26	4 to 6	7.4
29,398	19	28	4 to 6	7.1
29,460	17	25	4 to 6	7.1
30,486	19	27	4 to 6	6.9
30,687	17	24	4 to 6	6.8
31,659	19	26	4 to 6	6.6
32,021	17	23	4 to 6	6.5
32,925	19	25	4 to 6	6.4
34,202	15	19	4 to 6	6.1
34,297	19	24	4 to 6	6.1
35,587	23	28	4 to 6	5.9
35,788	19	23	4 to 6	5.8
36,905	23	27	4 to 6	5.7
37,134	24	28	4 to 6	5.6
38,226	15	17	4 to 6	5.5
38,509	24	27	4 to 6	5.4
38,763	17	19	4 to 6	5.4
39,857	23	25	4 to 6	5.2
40,228	26	28	4 to 6	5.2
41,518	23	24	4 to 6	5.0
41,590	24	25	4 to 6	5.0
41,776	27	28	4 to 6	5.0
43,323	23	23	4 to 6	4.8
44,927	28	27	4 to 6	4.7
44,989	27	26	4 to 6	4.6
45,206	24	23	4 to 6	4.6
46,655	28	26	4 to 6	4.5
46,789	27	25	4 to 6	4.5
47,090	25	23	4 to 6	4.4
48,420	19	17	4 to 6	4.3
48,738	27	24	4 to 6	4.3
48,974	26	23	4 to 6	4.3
50,543	28	24	4 to 6	4.1
50,857	27	23	4 to 6	4.1
52,443	23	19	4 to 6	4.0
52,741	28	23	4 to 6	4.0
54,724	24	19	4 to 6	3.8
57,004	25	19	4 to 6	3.7
58,613	23	17	4 to 6	3.6
59,284	26	19	4 to 6	3.5
61,162	24	17	4 to 6	3.4
61,564	27	19	4 to 6	3.4
63,710	25	17	4 to 6	3.3
63,844	28	19	4 to 6	3.3
66,258	26	17	4 to 6	3.2
66,428	23	15	4 to 6	3.1
68,807	27	17	4 to 6	3.0

**NOTE: See "General Planting Rate Information" and "Check Seed Population" pages for more information. Always field check seed population to verify planting rates.**

**EDGEVAC PLANTING RATES FOR CORN / POPCORN 39 CELL DISC  
28 TOOTH CONTACT WHEEL DRIVE SPROCKET  
APPROXIMATE SEEDS / ACRE FOR VARIOUS ROW WIDTHS**

30" Rows	Transmission Sprockets Drive Driven		Recomm. Speed Range (MPH)	Average Seed Spacing In Inches
29,538	15	28	4 to 6	7.1
30,632	15	27	4 to 6	6.8
31,810	15	26	4 to 6	6.6
33,083	15	25	4 to 6	6.3
33,477	17	28	4 to 6	6.2
34,461	15	24	4 to 6	6.1
34,717	17	27	4 to 6	6.0
35,960	15	23	4 to 6	5.8
36,052	17	26	4 to 6	5.8
37,415	19	28	4 to 6	5.6
37,494	17	25	4 to 6	5.6
38,801	19	27	4 to 6	5.4
39,056	17	24	4 to 6	5.4
40,293	19	26	4 to 6	5.2
40,754	17	23	4 to 6	5.1
41,905	19	25	4 to 6	5.0
43,530	15	19	4 to 6	4.8
43,651	19	24	4 to 6	4.8
45,292	23	28	4 to 6	4.6
45,549	19	23	4 to 6	4.6
46,970	23	27	4 to 6	4.5
47,261	24	28	4 to 6	4.4
48,651	15	17	4 to 6	4.3
49,012	24	27	4 to 6	4.3
49,334	17	19	4 to 6	4.2
50,727	23	25	4 to 6	4.1
51,200	26	28	4 to 6	4.1
52,841	23	24	4 to 6	4.0
52,933	24	25	4 to 6	4.0
53,169	27	28	4 to 6	3.9
55,138	23	23	4 to 6	3.8
57,180	28	27	4 to 6	3.7
57,259	27	26	4 to 6	3.7
57,535	24	23	4 to 6	3.6
59,380	28	26	4 to 6	3.5
59,549	27	25	4 to 6	3.5
59,933	25	23	4 to 6	3.5
61,625	19	17	4 to 6	3.4
62,030	27	24	4 to 6	3.4
62,330	26	23	4 to 6	3.4
64,328	28	24	4 to 6	3.3
64,727	27	23	4 to 6	3.2
66,746	23	19	4 to 6	3.1
67,125	28	23	4 to 6	3.1
69,648	24	19	4 to 6	3.0
72,550	25	19	4 to 6	2.9
74,599	23	17	4 to 6	2.8
75,452	26	19	4 to 6	2.8
77,842	24	17	4 to 6	2.7
78,354	27	19	4 to 6	2.7
81,086	25	17	4 to 6	2.6
81,256	28	19	4 to 6	2.6
84,329	26	17	4 to 6	2.5
84,545	23	15	4 to 6	2.5
87,572	27	17	4 to 6	2.4

**NOTE: See "General Planting Rate Information" and "Check Seed Population" pages for more information. Always field check seed population to verify planting rates.**

**EDGEVAC PLANTING RATES FOR LOW-RATE CORN / POPCORN 24 CELL DISC  
22 TOOTH CONTACT WHEEL DRIVE SPROCKET  
APPROXIMATE SEEDS / ACRE FOR VARIOUS ROW WIDTHS**

30" Rows	Transmission Sprockets Drive Driven		Recomm. Speed Range (MPH)	Average Seed Spacing In Inches
14,282	15	28	4 to 6	14.6
14,811	15	27	4 to 6	14.1
15,381	15	26	4 to 6	13.6
15,996	15	25	4 to 6	13.1
16,187	17	28	4 to 6	12.9
16,663	15	24	4 to 6	12.5
16,786	17	27	4 to 6	12.5
17,387	15	23	4 to 6	12.0
17,432	17	26	4 to 6	12.0
18,091	19	28	4 to 6	11.6
18,129	17	25	4 to 6	11.5
18,761	19	27	4 to 6	11.1
18,884	17	24	4 to 6	11.1
19,482	19	26	4 to 6	10.7
19,705	17	23	4 to 6	10.6
20,262	19	25	4 to 6	10.3
21,048	15	19	4 to 6	9.9
21,106	19	24	4 to 6	9.9
21,899	23	28	4 to 6	9.5
22,024	19	23	4 to 6	9.5
22,711	23	27	4 to 6	9.2
22,852	24	28	4 to 6	9.1
23,524	15	17	4 to 6	8.9
23,698	24	27	4 to 6	8.8
23,854	17	19	4 to 6	8.8
24,527	23	25	4 to 6	8.5
24,756	26	28	4 to 6	8.4
25,549	23	24	4 to 6	8.2
25,594	24	25	4 to 6	8.2
25,708	27	28	4 to 6	8.1
26,660	23	23	4 to 6	7.8
27,648	28	27	4 to 6	7.6
27,686	27	26	4 to 6	7.6
27,819	24	23	4 to 6	7.5
28,711	28	26	4 to 6	7.3
28,793	27	25	4 to 6	7.3
28,978	25	23	4 to 6	7.2
29,797	19	17	4 to 6	7.0
29,993	27	24	4 to 6	7.0
30,138	26	23	4 to 6	6.9
31,104	28	24	4 to 6	6.7
31,297	27	23	4 to 6	6.7
32,273	23	19	4 to 6	6.5
32,456	28	23	4 to 6	6.4
33,676	24	19	4 to 6	6.2
35,079	25	19	4 to 6	6.0
36,070	23	17	4 to 6	5.8
36,482	26	19	4 to 6	5.7
37,638	24	17	4 to 6	5.6
37,886	27	19	4 to 6	5.5
39,206	25	17	4 to 6	5.3
39,289	28	19	4 to 6	5.3
40,774	26	17	4 to 6	5.1
40,879	23	15	4 to 6	5.1
42,343	27	17	4 to 6	4.9

**NOTE: See "General Planting Rate Information" and "Check Seed Population" pages for more information. Always field check seed population to verify planting rates.**

**EDGEVAC PLANTING RATES FOR LOW-RATE CORN / POPCORN 24 CELL DISC  
28 TOOTH CONTACT WHEEL DRIVE SPROCKET  
APPROXIMATE HILLS / ACRE FOR VARIOUS ROW WIDTHS**

30" Rows	Transmission Sprockets		Recomm. Speed Range (MPH)	Average Seed Spacing In Inches
	Drive	Driven		
18,089	15	28	4 to 6	11.6
18,759	15	27	4 to 6	11.1
19,481	15	26	4 to 6	10.7
20,260	15	25	4 to 6	10.3
20,501	17	28	4 to 6	10.2
21,104	15	24	4 to 6	9.9
21,261	17	27	4 to 6	9.8
22,022	15	23	4 to 6	9.5
22,078	17	26	4 to 6	9.5
22,913	19	28	4 to 6	9.1
22,961	17	25	4 to 6	9.1
23,762	19	27	4 to 6	8.8
23,918	17	24	4 to 6	8.7
24,676	19	26	4 to 6	8.5
24,958	17	23	4 to 6	8.4
25,663	19	25	4 to 6	8.1
26,658	15	19	4 to 6	7.8
26,732	19	24	4 to 6	7.8
27,737	23	28	4 to 6	7.5
27,894	19	23	4 to 6	7.5
28,764	23	27	4 to 6	7.3
28,943	24	28	4 to 6	7.2
29,794	15	17	4 to 6	7.0
30,015	24	27	4 to 6	7.0
30,212	17	19	4 to 6	6.9
31,065	23	25	4 to 6	6.7
31,355	26	28	4 to 6	6.7
32,360	23	24	4 to 6	6.5
32,416	24	25	4 to 6	6.5
32,561	27	28	4 to 6	6.4
33,767	23	23	4 to 6	6.2
35,017	28	27	4 to 6	6.0
35,065	27	26	4 to 6	6.0
35,235	24	23	4 to 6	5.9
36,364	28	26	4 to 6	5.7
36,468	27	25	4 to 6	5.7
36,703	25	23	4 to 6	5.7
37,739	19	17	4 to 6	5.5
37,988	27	24	4 to 6	5.5
38,171	26	23	4 to 6	5.5
39,394	28	24	4 to 6	5.3
39,639	27	23	4 to 6	5.3
40,875	23	19	4 to 6	5.1
41,107	28	23	4 to 6	5.1
42,653	24	19	4 to 6	4.9
44,430	25	19	4 to 6	4.7
45,684	23	17	4 to 6	4.6
46,207	26	19	4 to 6	4.5
47,671	24	17	4 to 6	4.4
47,984	27	19	4 to 6	4.4
49,657	25	17	4 to 6	4.2
49,761	28	19	4 to 6	4.2
51,643	26	17	4 to 6	4.0
51,776	23	15	4 to 6	4.0
53,629	27	17	4 to 6	3.9

**NOTE: See "General Planting Rate Information" and "Check Seed Population" pages for more information. Always field check seed population to verify planting rates.**

**EDGEVAC PLANTING RATES FOR SOYBEAN AND MILO / GRAIN SORGHUM 60 CELL DISCS  
22 TOOTH CONTACT WHEEL DRIVE SPROCKET  
APPROXIMATE SEEDS / ACRE FOR VARIOUS ROW WIDTHS**

30" Rows	Transmission Sprockets		Recomm. Speed Range (MPH)	Average Seed Spacing In Inches
	Drive	Driven		
35,706	15	28	4 to 6	5.9
37,028	15	27	4 to 6	5.6
38,452	15	26	4 to 6	5.4
39,990	15	25	4 to 6	5.2
40,466	17	28	4 to 6	5.2
41,657	15	24	4 to 6	5.0
41,965	17	27	4 to 6	5.0
43,468	15	23	4 to 6	4.8
43,579	17	26	4 to 6	4.8
45,227	19	28	4 to 6	4.6
45,322	17	25	4 to 6	4.6
46,902	19	27	4 to 6	4.5
47,211	17	24	4 to 6	4.4
48,706	19	26	4 to 6	4.3
49,263	17	23	4 to 6	4.2
50,654	19	25	4 to 6	4.1
52,619	15	19	4 to 6	4.0
52,765	19	24	4 to 6	4.0
54,749	23	28	4 to 6	3.8
55,059	19	23	4 to 6	3.8
56,776	23	27	4 to 6	3.7
57,129	24	28	4 to 6	3.7
58,809	15	17	4 to 6	3.6
59,245	24	27	4 to 6	3.5
59,635	17	19	4 to 6	3.5
61,318	23	25	4 to 6	3.4
61,890	26	28	4 to 6	3.4
63,873	23	24	4 to 6	3.3
63,985	24	25	4 to 6	3.3
64,270	27	28	4 to 6	3.3
66,651	23	23	4 to 6	3.1
69,119	28	27	4 to 6	3.0
69,214	27	26	4 to 6	3.0
69,548	24	23	4 to 6	3.0
71,778	28	26	4 to 6	2.9
71,983	27	25	4 to 6	2.9
72,446	25	23	4 to 6	2.9
74,492	19	17	4 to 6	2.8
74,982	27	24	4 to 6	2.8
75,344	26	23	4 to 6	2.8
77,759	28	24	4 to 6	2.7
78,242	27	23	4 to 6	2.7
80,682	23	19	4 to 6	2.6
81,140	28	23	4 to 6	2.6
84,190	24	19	4 to 6	2.5
87,698	25	19	4 to 6	2.4
90,174	23	17	4 to 6	2.3
91,206	26	19	4 to 6	2.3
94,095	24	17	4 to 6	2.2
94,714	27	19	4 to 6	2.2
98,015	25	17	4 to 6	2.1
98,222	28	19	4 to 6	2.1
101,936	26	17	4 to 6	2.1
102,197	23	15	4 to 6	2.0
105,857	27	17	4 to 6	2.0

**NOTE: See "General Planting Rate Information" and "Check Seed Population" pages for more information. Always field check seed population to verify planting rates.**

**EDGEVAC PLANTING RATES FOR SOYBEAN AND MILO / GRAIN SORGHUM 60 CELL DISCS  
28 TOOTH CONTACT WHEEL DRIVE SPROCKET  
APPROXIMATE SEEDS / ACRE FOR VARIOUS ROW WIDTHS**

30" Rows	Transmission Sprockets		Recomm. Speed Range (MPH)	Average Seed Spacing In Inches
	Drive	Driven		
45,444	15	28	4 to 6	4.6
47,127	15	27	4 to 6	4.4
48,939	15	26	4 to 6	4.3
50,897	15	25	4 to 6	4.1
51,503	17	28	4 to 6	4.1
53,017	15	24	4 to 6	3.9
53,410	17	27	4 to 6	3.9
55,323	15	23	4 to 6	3.8
55,464	17	26	4 to 6	3.8
57,562	19	28	4 to 6	3.6
57,683	17	25	4 to 6	3.6
59,694	19	27	4 to 6	3.5
60,086	17	24	4 to 6	3.5
61,990	19	26	4 to 6	3.4
62,699	17	23	4 to 6	3.3
64,469	19	25	4 to 6	3.2
66,969	15	19	4 to 6	3.1
67,155	19	24	4 to 6	3.1
69,680	23	28	4 to 6	3.0
70,075	19	23	4 to 6	3.0
72,261	23	27	4 to 6	2.9
72,710	24	28	4 to 6	2.9
74,848	15	17	4 to 6	2.8
75,403	24	27	4 to 6	2.8
75,899	17	19	4 to 6	2.8
78,042	23	25	4 to 6	2.7
78,769	26	28	4 to 6	2.7
81,293	23	24	4 to 6	2.6
81,435	24	25	4 to 6	2.6
81,798	27	28	4 to 6	2.6
84,828	23	23	4 to 6	2.5
87,970	28	27	4 to 6	2.4
88,091	27	26	4 to 6	2.4
88,516	24	23	4 to 6	2.4
91,353	28	26	4 to 6	2.3
91,614	27	25	4 to 6	2.3
92,204	25	23	4 to 6	2.3
94,808	19	17	4 to 6	2.2
95,431	27	24	4 to 6	2.2
95,892	26	23	4 to 6	2.2
98,966	28	24	4 to 6	2.1
99,581	27	23	4 to 6	2.1
102,686	23	19	4 to 6	2.0
103,269	28	23	4 to 6	2.0
107,151	24	19	4 to 6	2.0
111,616	25	19	4 to 6	1.9
114,767	23	17	4 to 6	1.8
116,080	26	19	4 to 6	1.8
119,757	24	17	4 to 6	1.7
120,545	27	19	4 to 6	1.7
124,747	25	17	4 to 6	1.7
125,010	28	19	4 to 6	1.7
129,737	26	17	4 to 6	1.6
130,070	23	15	4 to 6	1.6
134,727	27	17	4 to 6	1.6

**NOTE: See "General Planting Rate Information" and "Check Seed Population" pages for more information. Always field check seed population to verify planting rates.**

**EDGEVAC PLANTING RATES FOR SOYBEAN 60 CELL DISC  
44 TOOTH CONTACT WHEEL DRIVE SPROCKET  
APPROXIMATE SEEDS / ACRE FOR VARIOUS ROW WIDTHS**

30" Rows	Transmission Sprockets		Recomm. Speed Range (MPH)	Average Seed Spacing In Inches
	Drive	Driven		
71,406	15	28	4 to 6	2.9
74,051	15	27	4 to 6	2.8
76,899	15	26	4 to 6	2.7
79,975	15	25	4 to 6	2.6
80,927	17	28	4 to 6	2.6
83,308	15	24	4 to 6	2.5
83,925	17	27	4 to 6	2.5
86,930	15	23	4 to 6	2.4
87,153	17	26	4 to 6	2.4
90,448	19	28	4 to 6	2.3
90,639	17	25	4 to 6	2.3
93,798	19	27	4 to 6	2.2
94,415	17	24	4 to 6	2.2
97,406	19	26	4 to 6	2.1
98,520	17	23	4 to 6	2.1
101,302	19	25	4 to 6	2.1
105,231	15	19	4 to 6	2.0
105,523	19	24	4 to 6	2.0
109,490	23	28	4 to 6	1.9
110,111	19	23	4 to 6	1.9
113,545	23	27	4 to 6	1.8
114,250	24	28	4 to 6	1.8
117,611	15	17	4 to 6	1.8
118,482	24	27	4 to 6	1.8
119,261	17	19	4 to 6	1.8
122,629	23	25	4 to 6	1.7
123,771	26	28	4 to 6	1.7
127,738	23	24	4 to 6	1.6
127,960	24	25	4 to 6	1.6
128,532	27	28	4 to 6	1.6
133,292	23	23	4 to 6	1.6
138,229	28	27	4 to 6	1.5
138,419	27	26	4 to 6	1.5
139,087	24	23	4 to 6	1.5
143,545	28	26	4 to 6	1.5
143,955	27	25	4 to 6	1.5
144,883	25	23	4 to 6	1.4
148,973	19	17	4 to 6	1.4
149,954	27	24	4 to 6	1.4
150,678	26	23	4 to 6	1.4
155,507	28	24	4 to 6	1.3
156,473	27	23	4 to 6	1.3
161,354	23	19	4 to 6	1.3
162,269	28	23	4 to 6	1.3
168,369	24	19	4 to 6	1.2
175,384	25	19	4 to 6	1.2
180,336	23	17	4 to 6	1.2
182,400	26	19	4 to 6	1.1
188,177	24	17	4 to 6	1.1
189,415	27	19	4 to 6	1.1
196,018	25	17	4 to 6	1.1
196,430	28	19	4 to 6	1.1
203,858	26	17	4 to 6	1.0
204,381	23	15	4 to 6	1.0
211,699	27	17	4 to 6	1.0

**NOTE: See "General Planting Rate Information" and "Check Seed Population" pages for more information. Always field check seed population to verify planting rates.**

**EDGEVAC PLANTING RATES FOR HIGH-RATE SOYBEAN 120 CELL DISC  
22 TOOTH CONTACT WHEEL DRIVE SPROCKET  
APPROXIMATE SEEDS / ACRE FOR VARIOUS ROW WIDTHS**

30" Rows	Transmission Sprockets		Recomm. Speed Range (MPH)	Average Seed Spacing In Inches
	Drive	Driven		
71,411	15	28	4 to 6	2.9
74,056	15	27	4 to 6	2.8
76,904	15	26	4 to 6	2.7
79,981	15	25	4 to 6	2.6
80,933	17	28	4 to 6	2.6
83,313	15	24	4 to 6	2.5
83,930	17	27	4 to 6	2.5
86,935	15	23	4 to 6	2.4
87,158	17	26	4 to 6	2.4
90,454	19	28	4 to 6	2.3
90,645	17	25	4 to 6	2.3
93,804	19	27	4 to 6	2.2
94,422	17	24	4 to 6	2.2
97,412	19	26	4 to 6	2.1
98,527	17	23	4 to 6	2.1
101,309	19	25	4 to 6	2.1
105,238	15	19	4 to 6	2.0
105,530	19	24	4 to 6	2.0
109,497	23	28	4 to 6	1.9
110,118	19	23	4 to 6	1.9
113,553	23	27	4 to 6	1.8
114,258	24	28	4 to 6	1.8
117,619	15	17	4 to 6	1.8
118,490	24	27	4 to 6	1.8
119,269	17	19	4 to 6	1.8
122,637	23	25	4 to 6	1.7
123,780	26	28	4 to 6	1.7
127,747	23	24	4 to 6	1.6
127,969	24	25	4 to 6	1.6
128,540	27	28	4 to 6	1.6
133,301	23	23	4 to 6	1.6
138,238	28	27	4 to 6	1.5
138,428	27	26	4 to 6	1.5
139,097	24	23	4 to 6	1.5
143,555	28	26	4 to 6	1.5
143,965	27	25	4 to 6	1.5
144,892	25	23	4 to 6	1.4
148,984	19	17	4 to 6	1.4
149,964	27	24	4 to 6	1.4
150,688	26	23	4 to 6	1.4
155,518	28	24	4 to 6	1.3
156,484	27	23	4 to 6	1.3
161,364	23	19	4 to 6	1.3
162,280	28	23	4 to 6	1.3
168,380	24	19	4 to 6	1.2
175,396	25	19	4 to 6	1.2
180,349	23	17	4 to 6	1.2
182,412	26	19	4 to 6	1.1
188,190	24	17	4 to 6	1.1
189,428	27	19	4 to 6	1.1
196,031	25	17	4 to 6	1.1
196,444	28	19	4 to 6	1.1
203,872	26	17	4 to 6	1.0
204,395	23	15	4 to 6	1.0
211,713	27	17	4 to 6	1.0

**NOTE: See "General Planting Rate Information" and "Check Seed Population" pages for more information. Always field check seed population to verify planting rates.**

**EDGEVAC PLANTING RATES FOR HIGH-RATE SOYBEAN 120 CELL DISC  
28 TOOTH CONTACT WHEEL DRIVE SPROCKET  
APPROXIMATE SEEDS / ACRE FOR VARIOUS ROW WIDTHS**

30" Rows	Transmission Sprockets		Recomm. Speed Range (MPH)	Average Seed Spacing In Inches
	Drive	Driven		
90,887	15	28	4 to 6	2.3
94,253	15	27	4 to 6	2.2
97,878	15	26	4 to 6	2.1
101,794	15	25	4 to 6	2.1
103,005	17	28	4 to 6	2.0
106,035	15	24	4 to 6	2.0
106,820	17	27	4 to 6	2.0
110,645	15	23	4 to 6	1.9
110,929	17	26	4 to 6	1.9
115,124	19	28	4 to 6	1.8
115,366	17	25	4 to 6	1.8
119,387	19	27	4 to 6	1.8
120,173	17	24	4 to 6	1.7
123,979	19	26	4 to 6	1.7
125,398	17	23	4 to 6	1.7
128,938	19	25	4 to 6	1.6
133,939	15	19	4 to 6	1.6
134,311	19	24	4 to 6	1.6
139,360	23	28	4 to 6	1.5
140,151	19	23	4 to 6	1.5
144,522	23	27	4 to 6	1.4
145,419	24	28	4 to 6	1.4
149,696	15	17	4 to 6	1.4
150,805	24	27	4 to 6	1.4
151,797	17	19	4 to 6	1.4
156,083	23	25	4 to 6	1.3
157,538	26	28	4 to 6	1.3
162,587	23	24	4 to 6	1.3
162,870	24	25	4 to 6	1.3
163,597	27	28	4 to 6	1.3
169,656	23	23	4 to 6	1.2
175,939	28	27	4 to 6	1.2
176,181	27	26	4 to 6	1.2
177,032	24	23	4 to 6	1.2
182,706	28	26	4 to 6	1.1
183,228	27	25	4 to 6	1.1
184,409	25	23	4 to 6	1.1
189,615	19	17	4 to 6	1.1
190,863	27	24	4 to 6	1.1
191,785	26	23	4 to 6	1.1
197,932	28	24	4 to 6	1.1
199,161	27	23	4 to 6	1.0
205,373	23	19	4 to 6	1.0
206,538	28	23	4 to 6	1.0
214,302	24	19	4 to 6	1.0
223,231	25	19	4 to 6	0.9
229,534	23	17	4 to 6	0.9
232,161	26	19	4 to 6	0.9
239,514	24	17	4 to 6	0.9
241,090	27	19	4 to 6	0.9
249,494	25	17	4 to 6	0.8
<b>NOTE: Planting rates over 250,000 seeds/acre are not recommended with subject seed disc and/or drive ratio.</b>	28	19	4 to 6	0.8
	26	17	4 to 6	0.8
	23	15	4 to 6	0.8
	27	17	4 to 6	0.8

**NOTE: See "General Planting Rate Information" and "Check Seed Population" pages for more information. Always field check seed population to verify planting rates.**

**EDGEVAC PLANTING RATES FOR HILL-DROP COTTON (3 SEEDS PER CELL), 20 CELL DISC  
22 TOOTH CONTACT WHEEL DRIVE SPROCKET  
APPROXIMATE HILLS / ACRE FOR VARIOUS ROW WIDTHS**

30" Rows	Transmission Sprockets		Recomm. Speed Range (MPH)	Average Seed Spacing In Inches
	Drive	Driven		
11,902	15	28	4 to 6	17.6
12,343	15	27	4 to 6	16.9
12,817	15	26	4 to 6	16.3
13,330	15	25	4 to 6	15.7
13,489	17	28	4 to 6	15.5
13,886	15	24	4 to 6	15.1
13,988	17	27	4 to 6	14.9
14,489	15	23	4 to 6	14.4
14,526	17	26	4 to 6	14.4
15,076	19	28	4 to 6	13.9
15,107	17	25	4 to 6	13.8
15,634	19	27	4 to 6	13.4
15,737	17	24	4 to 6	13.3
16,235	19	26	4 to 6	12.9
16,421	17	23	4 to 6	12.7
16,885	19	25	4 to 6	12.4
17,540	15	19	4 to 6	11.9
17,588	19	24	4 to 6	11.9
18,250	23	28	4 to 6	11.5
18,353	19	23	4 to 6	11.4
18,925	23	27	4 to 6	11.0
19,043	24	28	4 to 6	11.0
19,603	15	17	4 to 6	10.7
19,653	23	26	4 to 6	10.6
19,748	24	27	4 to 6	10.6
19,836	25	28	4 to 6	10.5
19,878	17	19	4 to 6	10.5
20,439	23	25	4 to 6	10.2
20,508	24	26	4 to 6	10.2
20,571	25	27	4 to 6	10.2
20,630	26	28	4 to 6	10.1
21,291	23	24	4 to 6	9.8
21,328	24	25	4 to 6	9.8
21,362	25	26	4 to 6	9.8
21,394	26	27	4 to 6	9.8
21,423	27	28	4 to 6	9.8
22,217	23	23	4 to 6	9.4
23,040	28	27	4 to 6	9.1
23,071	27	26	4 to 6	9.1
23,143	25	24	4 to 6	9.0
23,183	24	23	4 to 6	9.0
23,926	28	26	4 to 6	8.7
23,994	27	25	4 to 6	8.7
24,149	25	23	4 to 6	8.7
24,831	19	17	4 to 6	8.4
24,883	28	25	4 to 6	8.4
24,994	27	24	4 to 6	8.4
25,115	26	23	4 to 6	8.3
25,920	28	24	4 to 6	8.1
26,081	27	23	4 to 6	8.0
26,894	23	19	4 to 6	7.8
27,047	28	23	4 to 6	7.7
28,063	24	19	4 to 6	7.5
29,233	25	19	4 to 6	7.2
30,058	23	17	5 to 6	7.0

**NOTE: See "General Planting Rate Information" and "Check Seed Population" pages for more information. Always field check seed population to verify planting rates.**

**EDGEVAC PLANTING RATES FOR HILL-DROP COTTON (3 SEEDS PER CELL), 20 CELL DISC  
28 TOOTH CONTACT WHEEL DRIVE SPROCKET  
APPROXIMATE HILLS / ACRE FOR VARIOUS ROW WIDTHS**

30" Rows	Transmission Sprockets		Recomm. Speed Range (MPH)	Average Seed Spacing In Inches
	Drive	Driven		
15,148	15	28	4 to 6	13.8
15,709	15	27	4 to 6	13.3
16,313	15	26	4 to 6	12.8
16,966	15	25	4 to 6	12.3
17,168	17	28	4 to 6	12.2
17,672	15	24	4 to 6	11.8
17,803	17	27	4 to 6	11.7
18,441	15	23	4 to 6	11.3
18,488	17	26	4 to 6	11.3
19,187	19	28	4 to 6	10.9
19,228	17	25	4 to 6	10.9
19,898	19	27	4 to 6	10.5
20,029	17	24	4 to 6	10.4
20,663	19	26	4 to 6	10.1
20,900	17	23	4 to 6	10.0
21,490	19	25	4 to 6	9.7
22,323	15	19	4 to 6	9.4
22,385	19	24	4 to 6	9.3
23,227	23	28	4 to 6	9.0
23,358	19	23	4 to 6	9.0
24,087	23	27	4 to 6	8.7
24,237	24	28	4 to 6	8.6
24,949	15	17	4 to 6	8.4
25,013	23	26	4 to 6	8.4
25,134	24	27	4 to 6	8.3
25,246	25	28	4 to 6	8.3
25,300	17	19	4 to 6	8.3
26,014	23	25	4 to 6	8.0
26,101	24	26	4 to 6	8.0
26,181	25	27	4 to 6	8.0
26,256	26	28	4 to 6	8.0
27,098	23	24	4 to 6	7.7
27,145	24	25	4 to 6	7.7
27,188	25	26	4 to 6	7.7
27,229	26	27	4 to 6	7.7
27,266	27	28	4 to 6	7.7
28,276	23	23	4 to 6	7.4
29,323	28	27	4 to 6	7.1
29,364	27	26	4 to 6	7.1
29,454	25	24	4 to 6	7.1
29,505	24	23	4 to 6	7.1
30,451	28	26	4 to 6	6.9
30,538	27	25	4 to 6	6.8
30,735	25	23	4 to 6	6.8
31,603	19	17	4 to 6	6.6
31,669	28	25	4 to 6	6.6
31,810	27	24	4 to 6	6.6
31,964	26	23	4 to 6	6.5
32,989	28	24	4 to 6	6.3
33,194	27	23	4 to 6	6.3
34,229	23	19	4 to 6	6.1
34,423	28	23	4 to 6	6.1
35,717	24	19	4 to 6	5.9
37,205	25	19	4 to 6	5.6
38,256	23	17	5 to 6	5.5

**NOTE: See "General Planting Rate Information" and "Check Seed Population" pages for more information. Always field check seed population to verify planting rates.**

**EDGEVAC PLANTING RATES FOR COTTON / SMALL DRY EDIBLE BEAN/SUNFLOWER, 54 CELL DISC  
22 TOOTH CONTACT WHEEL DRIVE SPROCKET  
APPROXIMATE SEEDS / ACRE FOR VARIOUS ROW WIDTHS**

30" Rows	Transmission Sprockets		Recomm. Speed Range (MPH)	Average Seed Spacing In Inches
	Drive	Driven		
32,135	15	28	4 to 6	6.5
33,325	15	27	4 to 6	6.3
34,607	15	26	4 to 6	6.0
35,991	15	25	4 to 6	5.8
36,420	17	28	4 to 6	5.7
37,491	15	24	4 to 6	5.6
37,769	17	27	4 to 6	5.5
39,121	15	23	4 to 6	5.3
39,221	17	26	4 to 6	5.3
40,704	19	28	4 to 6	5.1
40,790	17	25	4 to 6	5.1
42,212	19	27	4 to 6	5.0
42,490	17	24	4 to 6	4.9
43,836	19	26	4 to 6	4.8
44,337	17	23	4 to 6	4.7
45,589	19	25	4 to 6	4.6
47,357	15	19	4 to 6	4.4
47,489	19	24	4 to 6	4.4
49,274	23	28	4 to 6	4.2
49,553	19	23	4 to 6	4.2
51,099	23	27	4 to 6	4.1
51,416	24	28	4 to 6	4.1
52,928	15	17	4 to 6	4.0
53,320	24	27	4 to 6	3.9
53,671	17	19	4 to 6	3.9
55,187	23	25	4 to 6	3.8
55,701	26	28	4 to 6	3.8
57,486	23	24	4 to 6	3.6
57,586	24	25	4 to 6	3.6
57,843	27	28	4 to 6	3.6
59,985	23	23	4 to 6	3.5
62,207	28	27	4 to 6	3.4
62,293	27	26	4 to 6	3.4
62,594	24	23	4 to 6	3.3
64,600	28	26	4 to 6	3.2
64,784	27	25	4 to 6	3.2
65,202	25	23	4 to 6	3.2
67,043	19	17	4 to 6	3.1
67,484	27	24	4 to 6	3.1
67,810	26	23	4 to 6	3.1
69,983	28	24	4 to 6	3.0
70,418	27	23	4 to 6	3.0
72,614	23	19	4 to 6	2.9
73,026	28	23	4 to 6	2.9
75,771	24	19	4 to 6	2.8
78,928	25	19	4 to 6	2.6
81,157	23	17	4 to 6	2.6
82,085	26	19	4 to 6	2.5
84,685	24	17	4 to 6	2.5
85,243	27	19	4 to 6	2.5
88,214	25	17	4 to 6	2.4
88,400	28	19	4 to 6	2.4
91,743	26	17	4 to 6	2.3
91,978	23	15	4 to 6	2.3
95,271	27	17	4 to 6	2.2

**NOTE: See "General Planting Rate Information" and "Check Seed Population" pages for more information. Always field check seed population to verify planting rates.**

**EDGEVAC PLANTING RATES FOR COTTON / SMALL DRY EDIBLE BEAN / SUNFLOWER, 54 CELL DISC  
28 TOOTH CONTACT WHEEL DRIVE SPROCKET  
APPROXIMATE SEEDS / ACRE FOR VARIOUS ROW WIDTHS**

30" Rows	Transmission Sprockets Drive Driven		Recomm. Speed Range (MPH)	Average Seed Spacing In Inches
40,899	15	28	4 to 6	5.1
42,414	15	27	4 to 6	4.9
44,045	15	26	4 to 6	4.7
45,807	15	25	4 to 6	4.6
46,352	17	28	4 to 6	4.5
47,716	15	24	4 to 6	4.4
48,069	17	27	4 to 6	4.3
49,790	15	23	4 to 6	4.2
49,918	17	26	4 to 6	4.2
51,806	19	28	4 to 6	4.0
51,915	17	25	4 to 6	4.0
53,724	19	27	4 to 6	3.9
54,078	17	24	4 to 6	3.9
55,791	19	26	4 to 6	3.7
56,429	17	23	4 to 6	3.7
58,022	19	25	4 to 6	3.6
60,272	15	19	4 to 6	3.5
60,440	19	24	4 to 6	3.5
62,712	23	28	4 to 6	3.3
63,068	19	23	4 to 6	3.3
65,035	23	27	4 to 6	3.2
65,439	24	28	4 to 6	3.2
67,363	15	17	4 to 6	3.1
67,862	24	27	4 to 6	3.1
68,309	17	19	4 to 6	3.1
70,238	23	25	4 to 6	3.0
70,892	26	28	4 to 6	2.9
73,164	23	24	4 to 6	2.9
73,291	24	25	4 to 6	2.9
73,619	27	28	4 to 6	2.8
76,345	23	23	4 to 6	2.7
79,173	28	27	4 to 6	2.6
79,282	27	26	4 to 6	2.6
79,665	24	23	4 to 6	2.6
82,218	28	26	4 to 6	2.5
82,453	27	25	4 to 6	2.5
82,984	25	23	4 to 6	2.5
85,327	19	17	4 to 6	2.5
85,888	27	24	4 to 6	2.4
86,303	26	23	4 to 6	2.4
89,069	28	24	4 to 6	2.3
89,623	27	23	4 to 6	2.3
92,418	23	19	4 to 6	2.3
92,942	28	23	4 to 6	2.2
96,436	24	19	4 to 6	2.2
100,454	25	19	4 to 6	2.1
103,291	23	17	4 to 6	2.0
104,472	26	19	4 to 6	2.0
107,781	24	17	4 to 6	1.9
108,490	27	19	4 to 6	1.9
112,272	25	17	4 to 6	1.9
112,509	28	19	4 to 6	1.9
116,763	26	17	4 to 6	1.8
117,063	23	15	4 to 6	1.8
121,254	27	17	4 to 6	1.7

**NOTE: See "General Planting Rate Information" and "Check Seed Population" pages for more information. Always field check seed population to verify planting rates.**

**EDGEVAC PLANTING RATES FOR SUNFLOWER, 54 CELL DISC  
15 TOOTH CONTACT WHEEL DRIVE SPROCKET / 19 TOOTH REVERSER DRIVE SPROCKET  
APPROXIMATE SEEDS / ACRE FOR VARIOUS ROW WIDTHS**

30" Rows	Transmission Sprockets		Recomm. Speed Range (MPH)	Average Seed Spacing In Inches
	Drive	Driven		
14,854	15	28	4 to 6	14.1
15,404	15	27	4 to 6	13.6
15,997	15	26	4 to 6	13.1
16,637	15	25	4 to 6	12.6
16,835	17	28	4 to 6	12.4
17,330	15	24	4 to 6	12.1
17,458	17	27	4 to 6	12.0
18,083	15	23	4 to 6	11.6
18,130	17	26	4 to 6	11.5
18,815	19	28	4 to 6	11.1
18,855	17	25	4 to 6	11.1
19,512	19	27	4 to 6	10.7
19,640	17	24	4 to 6	10.6
20,262	19	26	4 to 6	10.3
20,494	17	23	4 to 6	10.2
21,073	19	25	4 to 6	9.9
21,890	15	19	4 to 6	9.6
21,951	19	24	4 to 6	9.5
22,776	23	28	4 to 6	9.2
22,905	19	23	4 to 6	9.1
23,620	23	27	4 to 6	8.9
23,767	24	28	4 to 6	8.8
24,466	15	17	4 to 6	8.5
24,647	24	27	4 to 6	8.5
24,809	17	19	4 to 6	8.4
26,572	23	24	4 to 6	7.9
25,747	26	28	4 to 6	8.1
26,572	23	24	4 to 6	7.9
26,619	24	25	4 to 6	7.9
26,737	27	28	4 to 6	7.8
27,728	23	23	4 to 6	7.5
28,755	28	27	4 to 6	7.3
28,794	27	26	4 to 6	7.3
28,933	24	23	4 to 6	7.2
29,861	28	26	4 to 6	7.0
29,946	27	25	4 to 6	7.0
30,139	25	23	4 to 6	6.9
30,990	19	17	4 to 6	6.7
31,194	27	24	4 to 6	6.7
31,344	26	23	4 to 6	6.7
32,349	28	24	4 to 6	6.5
32,550	27	23	4 to 6	6.4
33,565	23	19	4 to 6	6.2
33,755	28	23	4 to 6	6.2
35,024	24	19	4 to 6	6.0
36,484	25	19	4 to 6	5.7
37,514	23	17	4 to 6	5.6
37,943	26	19	4 to 6	5.5
39,145	24	17	4 to 6	5.3
39,402	27	19	4 to 6	5.3
40,776	25	17	4 to 6	5.1
40,862	28	19	4 to 6	5.1
42,407	26	17	4 to 6	4.9
42,516	23	15	4 to 6	4.9
44,038	27	17	4 to 6	4.7

**NOTE: See "General Planting Rate Information" and "Check Seed Population" pages for more information. Always field check seed population to verify planting rates.**

**EDGEVAC PLANTING RATES FOR LARGE DRY EDIBLE BEAN, 54 CELL DISC  
22 TOOTH CONTACT WHEEL DRIVE SPROCKET  
APPROXIMATE SEEDS / ACRE FOR VARIOUS ROW WIDTHS**

30" Rows	Transmission Sprockets Drive Driven		Recomm. Speed Range (MPH)	Average Seed Spacing In Inches
32,135	15	28	4 to 6	6.5
33,325	15	27	4 to 6	6.3
34,607	15	26	4 to 6	6.0
35,991	15	25	4 to 6	5.8
36,420	17	28	4 to 6	5.7
37,491	15	24	4 to 6	5.6
37,769	17	27	4 to 6	5.5
39,121	15	23	4 to 6	5.3
39,221	17	26	4 to 6	5.3
40,704	19	28	4 to 6	5.1
40,790	17	25	4 to 6	5.1
42,212	19	27	4 to 6	5.0
42,490	17	24	4 to 6	4.9
43,836	19	26	4 to 6	4.8
44,337	17	23	4 to 6	4.7
45,589	19	25	4 to 6	4.6
47,357	15	19	4 to 6	4.4
47,489	19	24	4 to 6	4.4
49,274	23	28	4 to 6	4.2
49,553	19	23	4 to 6	4.2
51,099	23	27	4 to 6	4.1
51,416	24	28	4 to 6	4.1
52,928	15	17	4 to 6	4.0
53,320	24	27	4 to 6	3.9
53,671	17	19	4 to 6	3.9
55,187	23	25	4 to 6	3.8
55,701	26	28	4 to 6	3.8
57,486	23	24	4 to 6	3.6
57,586	24	25	4 to 6	3.6
57,843	27	28	4 to 6	3.6
59,985	23	23	4 to 6	3.5
62,207	28	27	4 to 6	3.4
62,293	27	26	4 to 6	3.4
62,594	24	23	4 to 6	3.3
64,600	28	26	4 to 6	3.2
64,784	27	25	4 to 6	3.2
65,202	25	23	4 to 6	3.2
67,043	19	17	4 to 6	3.1
67,484	27	24	4 to 6	3.1
67,810	26	23	4 to 6	3.1
69,983	28	24	4 to 6	3.0
70,418	27	23	4 to 6	3.0
72,614	23	19	4 to 6	2.9
73,026	28	23	4 to 6	2.9
75,771	24	19	4 to 6	2.8
78,928	25	19	4 to 6	2.6
81,157	23	17	4 to 6	2.6
82,085	26	19	4 to 6	2.5
84,685	24	17	4 to 6	2.5
85,243	27	19	4 to 6	2.5
88,214	25	17	4 to 6	2.4
88,400	28	19	4 to 6	2.4
91,743	26	17	4 to 6	2.3
91,978	23	15	4 to 6	2.3
95,271	27	17	4 to 6	2.2

**NOTE: See "General Planting Rate Information" and "Check Seed Population" pages for more information. Always field check seed population to verify planting rates.**

**EDGEVAC PLANTING RATES FOR LARGE DRY EDIBLE BEAN 54 CELL DISC  
28 TOOTH CONTACT WHEEL DRIVE SPROCKET  
APPROXIMATE SEEDS / ACRE FOR VARIOUS ROW WIDTHS**

30" Rows	Transmission Sprockets Drive Driven		Recomm. Speed Range (MPH)	Average Seed Spacing In Inches
40,899	15	28	4 to 6	5.1
42,414	15	27	4 to 6	4.9
44,045	15	26	4 to 6	4.7
45,807	15	25	4 to 6	4.6
46,352	17	28	4 to 6	4.5
47,716	15	24	4 to 6	4.4
48,069	17	27	4 to 6	4.3
49,790	15	23	4 to 6	4.2
49,918	17	26	4 to 6	4.2
51,806	19	28	4 to 6	4.0
51,915	17	25	4 to 6	4.0
53,724	19	27	4 to 6	3.9
54,078	17	24	4 to 6	3.9
55,791	19	26	4 to 6	3.7
56,429	17	23	4 to 6	3.7
58,022	19	25	4 to 6	3.6
60,272	15	19	4 to 6	3.5
60,440	19	24	4 to 6	3.5
62,712	23	28	4 to 6	3.3
63,068	19	23	4 to 6	3.3
65,035	23	27	4 to 6	3.2
65,439	24	28	4 to 6	3.2
67,363	15	17	4 to 6	3.1
67,862	24	27	4 to 6	3.1
68,309	17	19	4 to 6	3.1
70,238	23	25	4 to 6	3.0
70,892	26	28	4 to 6	2.9
73,164	23	24	4 to 6	2.9
73,291	24	25	4 to 6	2.9
73,619	27	28	4 to 6	2.8
76,345	23	23	4 to 6	2.7
79,173	28	27	4 to 6	2.6
79,282	27	26	4 to 6	2.6
79,665	24	23	4 to 6	2.6
82,218	28	26	4 to 6	2.5
82,453	27	25	4 to 6	2.5
82,984	25	23	4 to 6	2.5
85,327	19	17	4 to 6	2.5
85,888	27	24	4 to 6	2.4
86,303	26	23	4 to 6	2.4
89,069	28	24	4 to 6	2.3
89,623	27	23	4 to 6	2.3
92,418	23	19	4 to 6	2.3
92,942	28	23	4 to 6	2.2
96,436	24	19	4 to 6	2.2
100,454	25	19	4 to 6	2.1
103,291	23	17	4 to 6	2.0
104,472	26	19	4 to 6	2.0
107,781	24	17	4 to 6	1.9
108,490	27	19	4 to 6	1.9
112,272	25	17	4 to 6	1.9
112,509	28	19	4 to 6	1.9
116,763	26	17	4 to 6	1.8
117,063	23	15	4 to 6	1.8
121,254	27	17	4 to 6	1.7

**NOTE: See "General Planting Rate Information" and "Check Seed Population" pages for more information. Always field check seed population to verify planting rates.**

**LIQUID FERTILIZER PISTON PUMP APPLICATION RATES  
GALLONS PER ACRE**

**Model NGP-6055 Pumps With 18 Tooth Sprocket  
(Planter equipped with two piston pumps.)**

Pump Setting	1	2	3	4	5	6	7	8	9	10
24 Row 30"	4.4	9.2	13.6	18.2	22.8	27.4	32.0	36.6	41.2	45.6

**Model NGP-7055 Pumps With 18 Tooth Sprocket  
(Planter equipped with two piston pumps.)**

Pump Setting	1	2	3	4	5	6	7	8	9	10
24 Row 30"	3.7	7.4	11.1	14.8	18.5	22.1	25.8	29.5	33.2	36.9

Charts are for planters equipped with contact drive. Check tires for correct operating pressure.

Charts calculated based on a solution weighing ten pounds per gallon.

**NOTE: Fertilizer application rates can vary from weights calculated in above chart. Make field checks to be sure you are applying fertilizer at desired rate.**

To check the exact number of gallons your fertilizer attachment will actually deliver on a 30" row spacing:

1. Remove hose from one fertilizer opener and insert it into a collection container secured planter frame.
2. Engage fertilizer attachment and drive forward for 174'.
3. Measure fluid ounces caught in container and multiply by 100. Divide that amount by 128. Result is gallons fertilizer delivered per acre when planting in 30" rows. To convert this delivery rate for other row widths, multiply by the following conversion factors:

20" x 1.50      22" x 1.36      38" x 0.79

4. Rinse collection container and repeat test on other rows if necessary.

**DRY INSECTICIDE APPLICATION RATES**  
**APPROXIMATE POUNDS/ACRE AT 5 MPH (8 KPH)**

Meter Setting	30" Rows
<b>CLAY GRANULES</b>	
10	4.9
11	5.4
12	6.1
13	6.9
14	7.7
15	8.5
16	9.6
17	10.7
18	11.4
19	13.1
20	14.2
21	15.5
22	16.4
23	17.2
24	18.8
25	20.9
26	23.0
27	24.1
28	25.4
29	27.8
30	29.6
<b>SAND GRANULES</b>	
5	2.9
6	4.9
7	5.3
8	6.3
9	7.8
10	8.9
11	10.2
12	11.2
13	12.6
14	14.1
15	15.5
16	17.5
17	19.4
18	21.8
19	24.3
20	25.7
21	27.6
22	29.6
23	32.0
24	34.4
25	36.9

**NOTE:** Chart represents average values and should be used only as a starting point. Granular chemical flows through meter opening at a nearly uniform rate regardless of roller speed. Your actual rate will vary depending on insecticide, planting speed, and plant population. Planting speed/ground speed has the greatest effect on application rate.

Field check your actual rate with insecticide you are using at speed and population you will be planting. See "Checking Granular Chemical Application Rate" in Machine Operation section for more information..

**DRY HERBICIDE APPLICATION RATES**  
**APPROXIMATE POUNDS/ACRE AT 5 MPH (8 KPH)**

**CLAY GRANULES**

Meter Setting	30" Rows
10	4.7
11	5.2
12	5.8
13	6.5
14	7.3
15	8.2
16	9.0
17	9.9
18	10.7
19	11.6
20	12.6
21	13.6
22	14.6
23	15.7
24	17.0
25	18.1
26	19.4
27	20.9
28	22.6
29	24.3
30	26.7

**NOTE: Chart represents average values and should be used only as a starting point. Granular chemical flows through given meter opening at a nearly uniform rate regardless of roller speed. Your actual rate will vary depending on specific herbicide, planting speed, and plant population. Planting speed/ground speed has the greatest effect on application rate.**

Field check your actual rate with herbicide you are using at speed and population you will be planting. See "Checking Granular Chemical Application Rate" in Machine Operation section for more information.

## LUBRICATION

Following pages show locations of all lubrication points. Proper lubrication of moving parts helps ensure efficient operation of your Kinze planter and prolongs the life of friction producing parts.

### LUBRICATION SYMBOLS

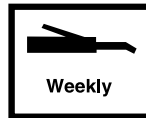
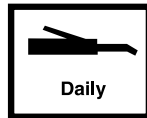

Lubricate at frequency indicated with SAE multipurpose grease.

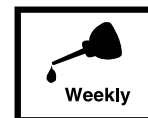

Lubricate at frequency indicated with high quality SAE 10 weight oil or spray lubricant.

### SEALED BEARINGS

Sealed bearings are used on your Kinze planter to provide trouble free operation.

These are located on drive shafts, row units, and transmission bearings. Sealed bearings are lubricated for life and are not serviceable.

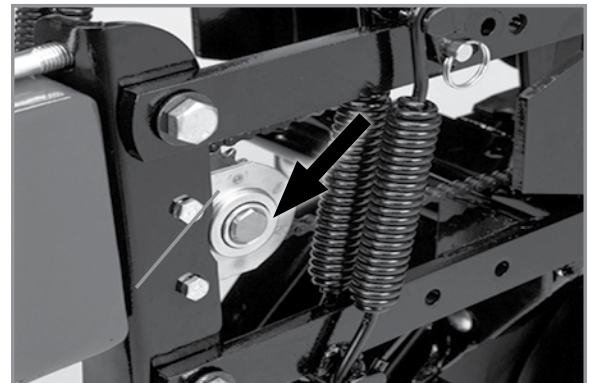

Sealed bearing (Typical)

### AIR CLUTCH LUBRICATION

Lubricate air clutches every 75-100 hours.

Remove Phillips head screw and spray a 1-2 second burst of silicone spray into each clutch. Reinstall screw.

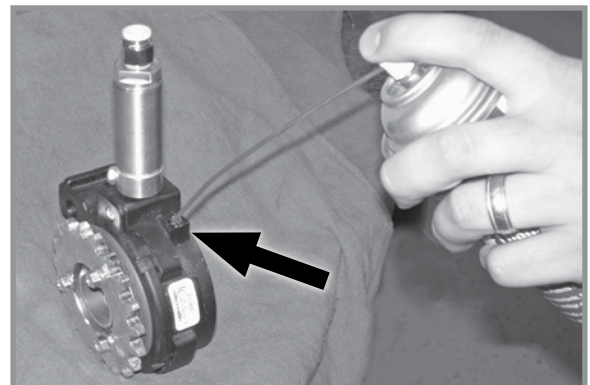

Air clutch lubrication

### WHEEL BEARINGS

All drive, transport, and marker hub wheel bearings should be repacked annually and checked for wear.

1. Raise wheel off ground.
2. Check for bearing endplay by moving wheel side to side.
3. Rotate wheel to check for bearing roughness. If bearings sound rough, remove hub and inspect bearings.

**NOTE: To repack wheel hubs, follow procedure outlined for wheel bearing replacement in this section except bearings and bearing cups are reused.**

### DRIVE CHAINS

Lubricate all transmission and drive chains daily with a high quality chain lubricant. Extreme operating conditions such as dirt, temperature, or speed may require more frequent lubrication.

If a chain becomes stiff, it should be removed, soaked, and washed in solvent to loosen and remove dirt from joints. Soak chain in oil so lubricant can penetrate between rollers and bushings.

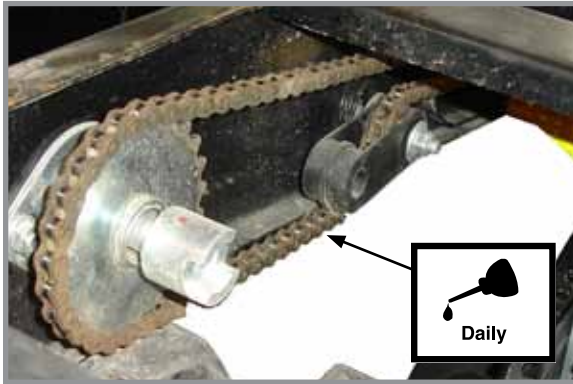

Row unit granular chemical drive chains

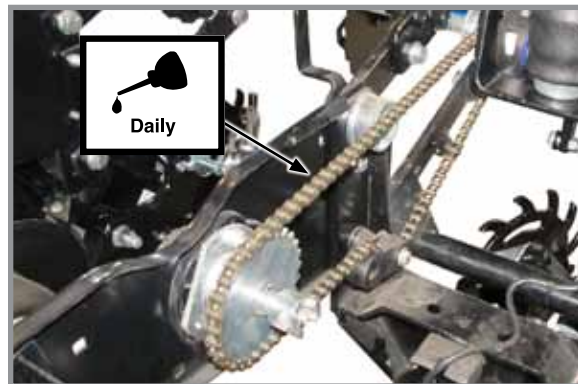

Row unit drive chains



Contact wheel drive chains

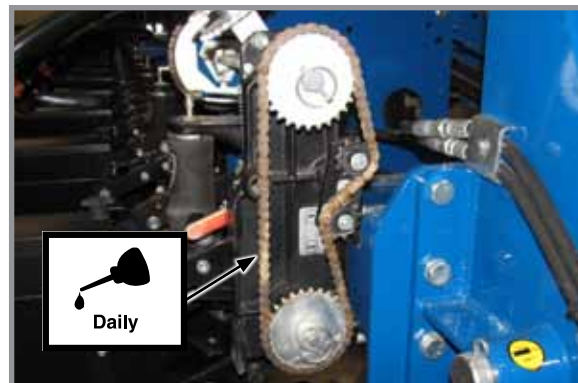

Transmission chains

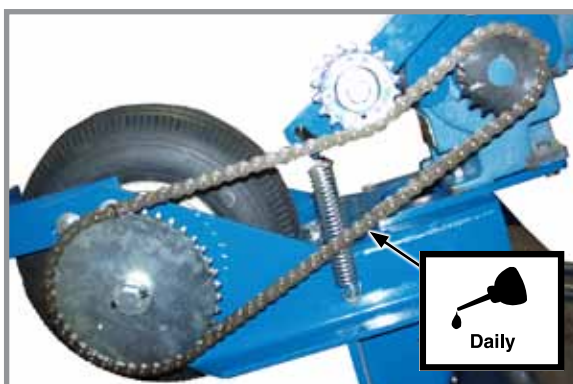

Optional piston pump drive chain

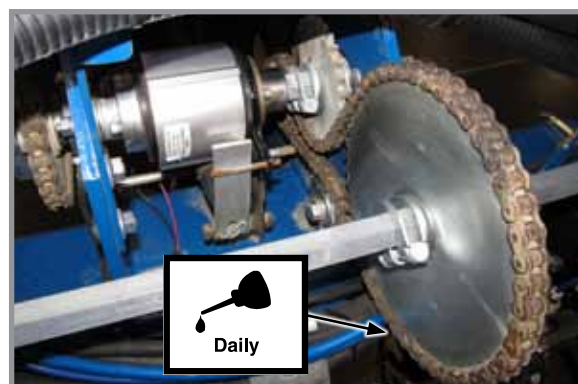

Inner module (point row clutch) drive chains

## BUSHINGS

Lubricate bushings at frequency indicated.

Check each bolt for proper torque. If bolt is loose, removed it and inspect bushing for cracks and wear. Replace bushing if necessary. Use **only hardened flat washers**. Replace damaged flat washers with proper part. Torque hardware to 130 ft-lb (176.2 N-m).

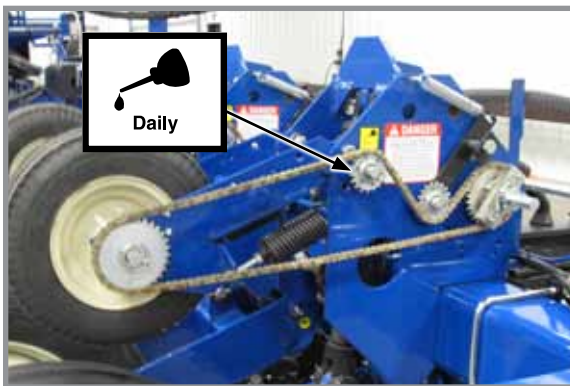

Contact wheel arm (2 per assembly)

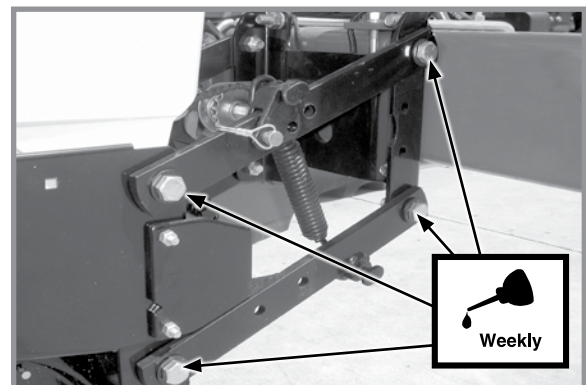

Row unit parallel linkages (8 per row)

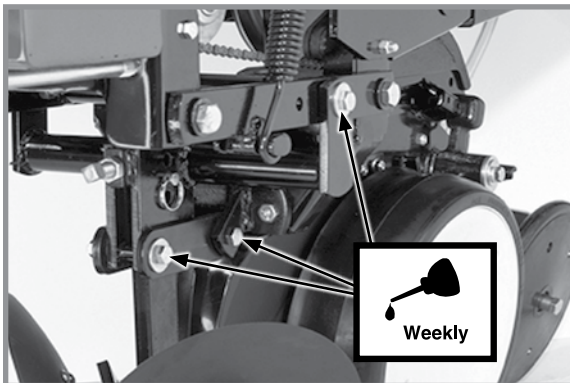

Row unit mounted disc furrower parallel linkages (6 per row)

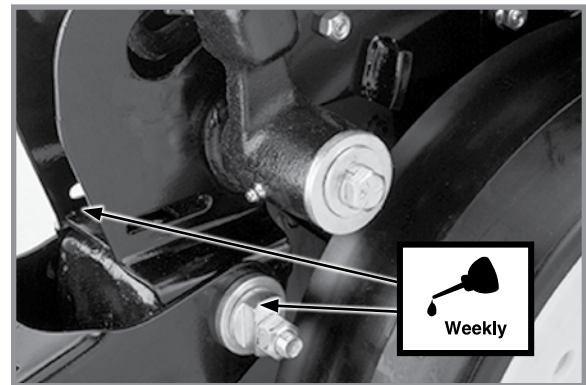

Row unit "v" closing wheel, covering discs/  
single press wheel and/or drag closing wheel  
eccentric bushings (2 per row)

## SLIDING HITCH LINKAGE

Inspect linkage daily to ensure free movement of axle links in slides.

Keep axle link slides clean. **DO NOT GREASE** the axle link slides. Powdered graphite may be used if lubrication is desired.

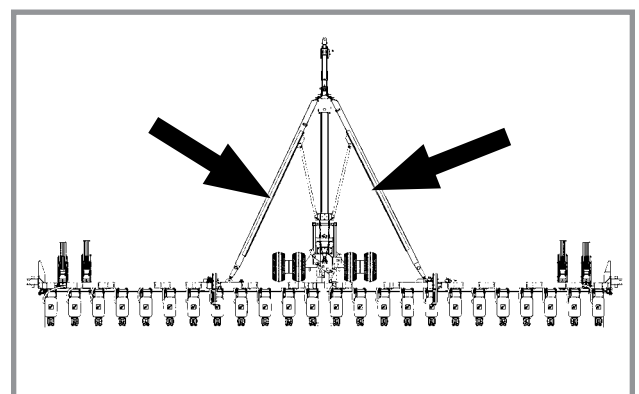

## PTO SHAFT COUPLING

Clean and grease PTO shaft coupling each time pump is installed.

Apply coating of high-speed industrial coupling grease, such as Chevron® Coupling Grease meeting AGMA CG-1 and CG-2 Standards to extend shaft spline life.



PTO pump installed

## WRAP SPRING WRENCH ASSEMBLY

Wrap spring wrench components may require occasional lubrication to operate correctly. Disassembly is required to lubricate.

1. Remove ¼"-20 x ½" cap screw securing idler with sprockets to wrench tightener shaft and remove wrap spring wrench from planter.
2. Tip wrap spring wrench on its side and lubricate using a high quality spray lubricant. Lubricant must be absorbed into wrap spring area.
3. Reinstall wrap spring wrench on planter.

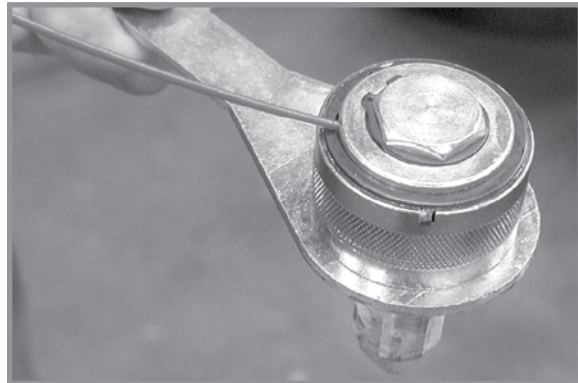

Wrap spring wrench lubrication

## LIQUID FERTILIZER PISTON PUMP CRANKCASE OIL LEVEL

Check crankcase oil daily and maintain at oil level check plug. Fill as needed with EP 90 weight gear oil. Total oil capacity is approximately ¾ pint.

Refer to operator and instruction manual supplied with pump and flow divider for more information.

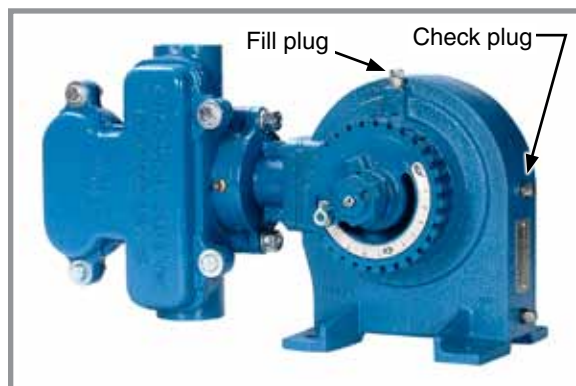

Piston pump oil fill and check plug locations

**GREASE FITTINGS**

**⚠ WARNING**

Uncontrolled machine movement can crush or cause loss of control resulting in death, serious injury, or damage to property and equipment. Install all safety lockup devices before working under or transporting this equipment.

Parts equipped with grease fittings should be lubricated at frequency indicated with an SAE multipurpose grease. Clean fitting thoroughly before using grease gun. Frequency of lubrication recommended is based on normal operating conditions. Severe or unusual conditions may require more frequent attention.

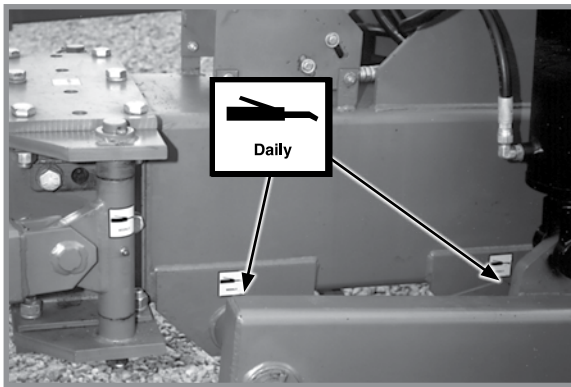

**Axle and automatic safety lock pivots (7)**

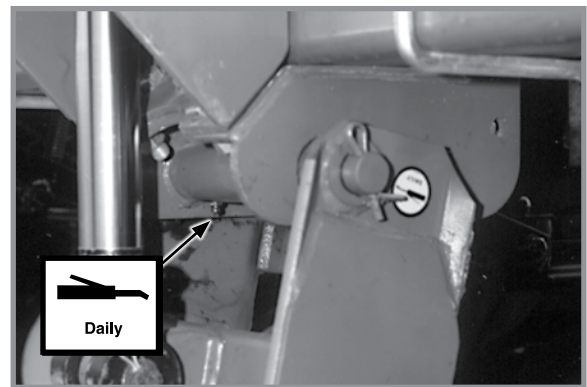

**Ground drive wheel pivot (2 per wheel module)**

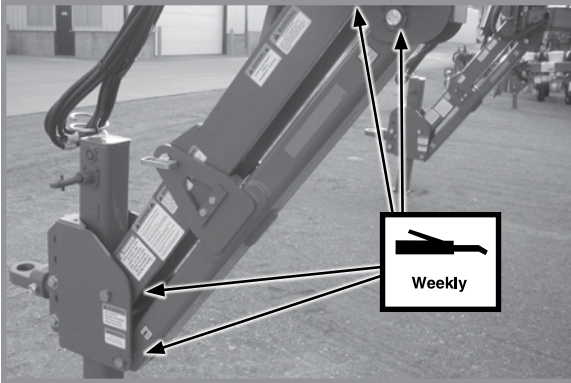

**Upper and lower hitch linkage (2 per link)**

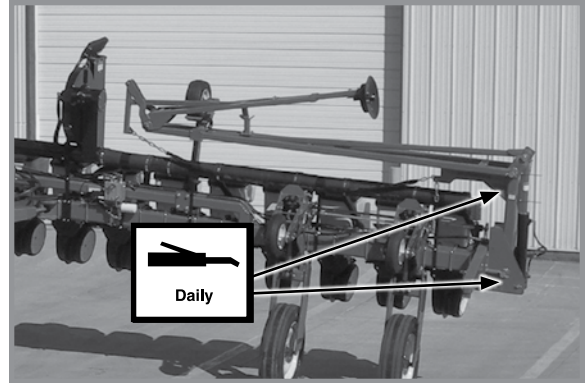

**Row Marker Assemblies (11 per side)**

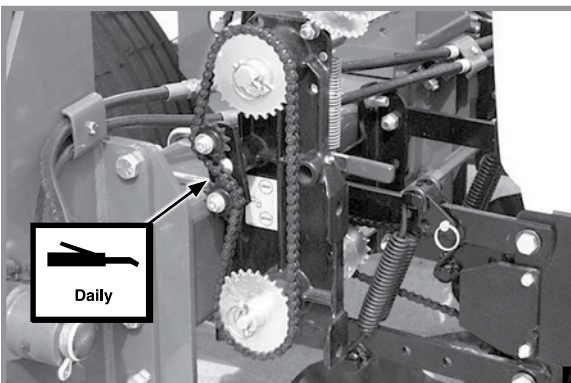

**Seed rate transmission assembly idler pivot (1 per assembly)**

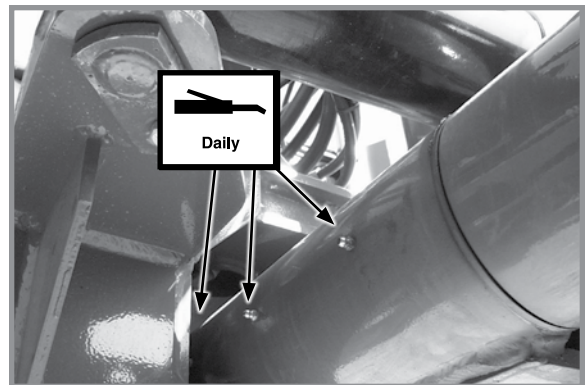

**Wing pivot knuckle (3 per knuckle on horizontal shaft)**

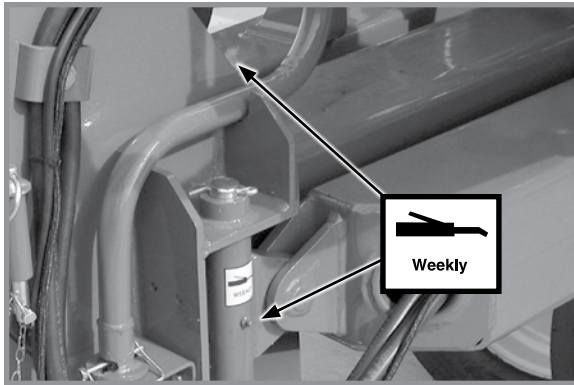

Link assemblies (1 per assembly)  
Front wear pads (4)

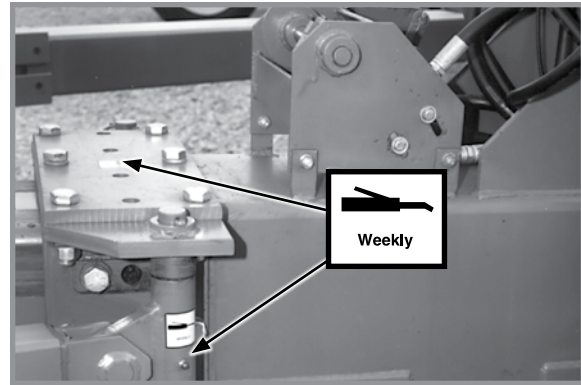

Axle link assemblies (1 per assembly)  
Rear wear pads (2 sets - 16)

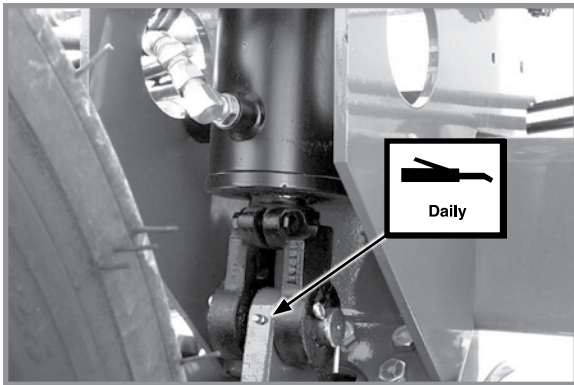

Wheel module lift cylinder mount  
(1 per wheel module)

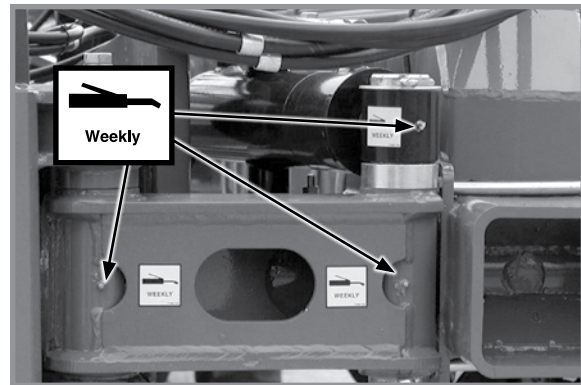

Wing pivot knuckle - 1 per knuckle on shaft  
Helper cylinders (1 per cylinder)

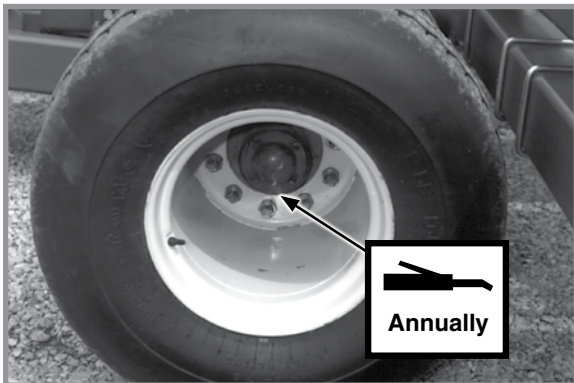

Transport wheel bearing (1 per wheel hub)

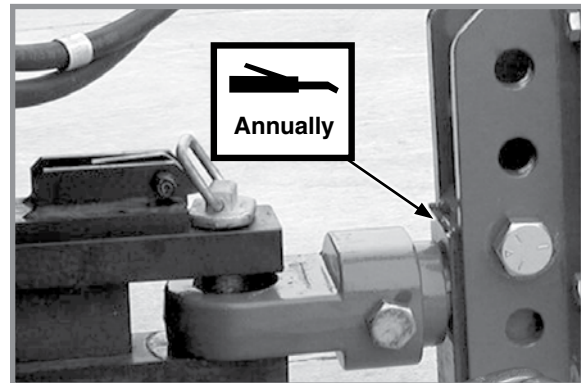

Swivel block (1)

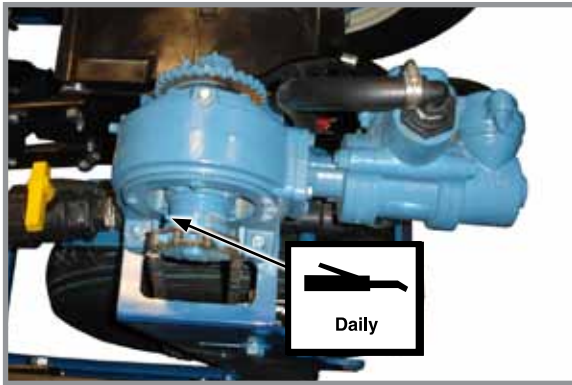

**Piston pump L.H. side (1)**

Fill until grease seeps out of bottom drain hole.

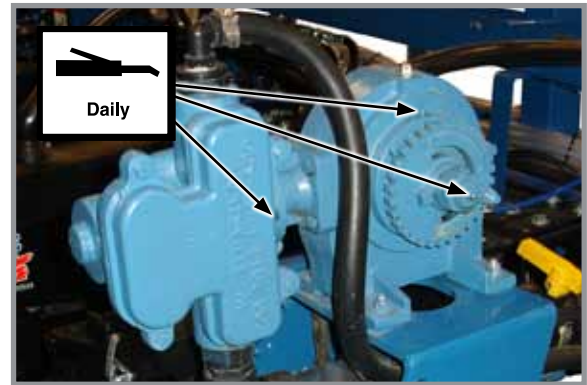

**Piston pump R.H. side (3)**

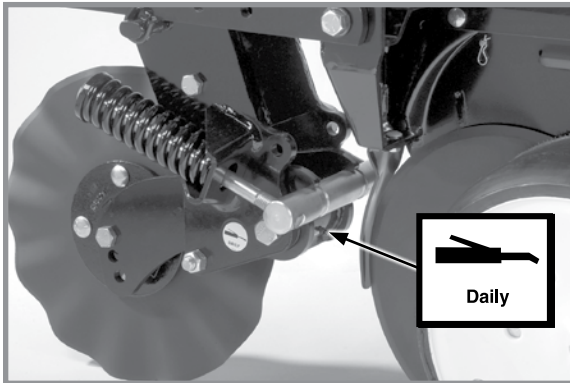

**Frame Mounted Coulter (1 per arm)**



**Notched single disc opener (1 per arm)**

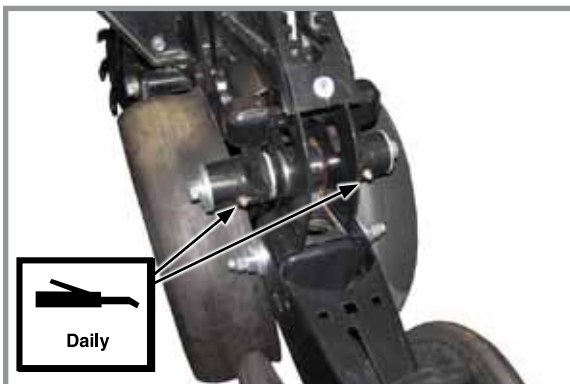

**Gauge wheel arms (2)**

Seals in gauge wheel arm are installed with lip facing out to allow grease to purge dirt away from seal. Pump grease into arm until fresh grease appears between washers and arm.

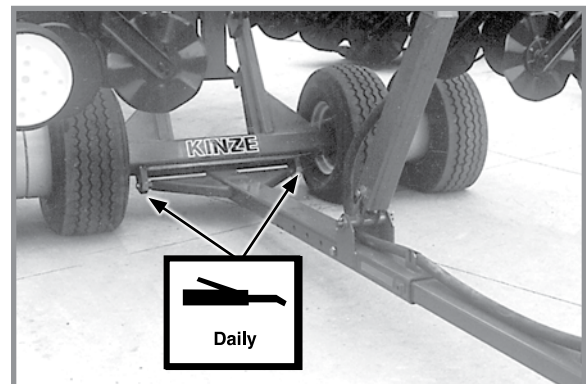

**Rear trailer hitch pivot (2)**

**MOUNTING BOLTS AND HARDWARE**

Before operating planter for the first time, check all hardware is tight. Check all hardware again after first 50 hours of operation and beginning of each planting season.

All hardware used on the Kinze planter is Grade 5 (high strength) unless otherwise noted. Grade 5 cap screws are marked with three radial lines on the head. Hardware must be replaced with equal size, strength, and thread type.

**! WARNING**

**Loose transport wheel lug nuts can result in wheel separation from planter and can result in death, serious injury, and damage to property and equipment. Check transport wheel lug nut torque before operating planter for the first time and periodically thereafter.**

**NOTICE**

Over-tightening hardware can reduce its shock load capacity and cause equipment failure.



**GRADE 2**  
No Marks



**GRADE 5**  
3 Marks



**GRADE 8**  
6 Marks

**TORQUE VALUES CHART - PLATED HARDWARE**

Diameter	Grade 2		Grade 5		Grade 8	
	Coarse	Fine	Coarse	Fine	Coarse	Fine
1/4"	50 in-lb	56 in-lb	76 in-lb	87 in-lb	9 ft-lb	10 ft-lb
5/16"	8 ft-lb	9 ft-lb	13 ft-lb	14 ft-lb	18 ft-lb	20 ft-lb
3/8"	15 ft-lb	17 ft-lb	23 ft-lb	26 ft-lb	33 ft-lb	37 ft-lb
7/16"	25 ft-lb	27 ft-lb	37 ft-lb	41 ft-lb	52 ft-lb	58 ft-lb
1/2"	35 ft-lb	40 ft-lb	57 ft-lb	64 ft-lb	80 ft-lb	90 ft-lb
9/16"	50 ft-lb	60 ft-lb	80 ft-lb	90 ft-lb	115 ft-lb	130 ft-lb
5/8"	70 ft-lb	80 ft-lb	110 ft-lb	125 ft-lb	160 ft-lb	180 ft-lb
3/4"	130 ft-lb	145 ft-lb	200 ft-lb	220 ft-lb	280 ft-lb	315 ft-lb
7/8"	125 ft-lb	140 ft-lb	320 ft-lb	350 ft-lb	450 ft-lb	500 ft-lb
1"	190 ft-lb	205 ft-lb	480 ft-lb	530 ft-lb	675 ft-lb	750 ft-lb
1 1/8"	265 ft-lb	300 ft-lb	600 ft-lb	670 ft-lb	960 ft-lb	1075 ft-lb
1 1/4"	375 ft-lb	415 ft-lb	840 ft-lb	930 ft-lb	1360 ft-lb	1500 ft-lb
1 3/8"	490 ft-lb	560 ft-lb	1100 ft-lb	1250 ft-lb	1780 ft-lb	2030 ft-lb
1 1/2"	650 ft-lb	730 ft-lb	1450 ft-lb	1650 ft-lb	2307 ft-lb	2670 ft-lb

**NOTE: Torque unplated hardware and bolts with lock nuts approximately 1/3 higher than above values. Torque bolts lubricated prior to installation to 70% of value shown in chart.**

**TORQUE VALUES- ALUMINUM**

Diameter	Torque Value
1/8"	180-220 in-lb
3/8"	350-380 in-lb
1/2"	350-400 in-lb
3/4"	350-400 in-lb

**NOTE: Use these torque values with pneumatic down pressure components.**

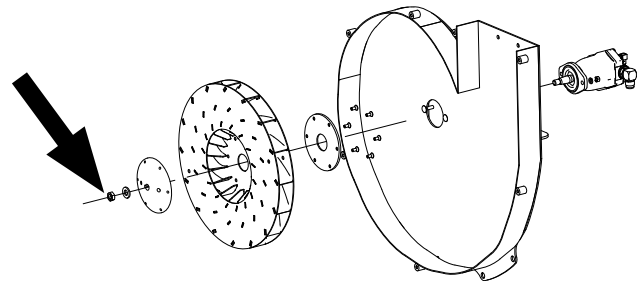

**NOTE: Torque EdgeVac fan impeller assembly to motor shaft 5/8"-18 hex jam nut 50 ft-lb (67.8 N-m).**

**TIRE PRESSURE**

**! WARNING**

**Explosive separation of rim and tire can cause death or serious injury. Overinflation, rim and tire servicing, improper use of rims and tires, worn, or improperly maintained tires could result in a tire explosion.**

- Maintain proper tire pressure. Inflating a tire above or below the recommended pressure can cause tire damage.
- Mount tires only by properly trained personnel using proper equipment.
- Replace tires with cuts or bubbles. Replace damaged rims. Replace missing lug bolts and nuts.
- Do not weld or heat wheel assembly. Heating increases tire pressure.

**TRANSPORT TIRES**

**! WARNING**

**Over-inflation of tires can result in explosive separation of rim and tire and cause death or serious injury. Different size rims are designed for different tire pressures. Inflate to correct pressure for specific rim size.**

Do not exceed following maximum pressures:

- Rims stamped with “224”: 75 psi (517.1 kPa) maximum pressure.
- Rims stamped with “276”: 100 psi (689.4 kPa) maximum pressure.

**INFLATION SPECIFICATIONS**

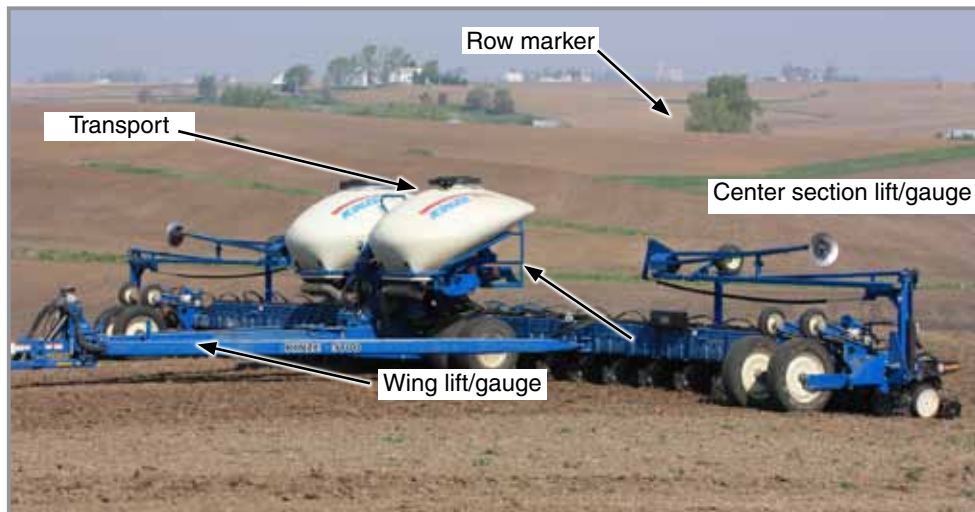

**Tire locations**

Ground drive (wings) 255-70R 22.5 .....	75 psi (517.1 kPa)
Transport - 36" x 16" x 17.5" .....	75 psi (517.1 kPa)
Contact drive - 4.80" x 8" .....	50 psi (344.7 kPa)
Row marker - 16" x 6.5" x 8" .....	14 psi (96.5 kPa)
Liquid fertilizer piston pump 4.10" x 6" .....	50 psi (344.7 kPa)

**This page left blank intentionally.**

### SINGLE AND TWO-SPEED POINT ROW CLUTCH MAINTENANCE

Point row clutch is permanently lubricated and sealed and requires no periodic maintenance. Two-speed point row clutch is similar in design and operation to standard point row clutch except for two-speed function.

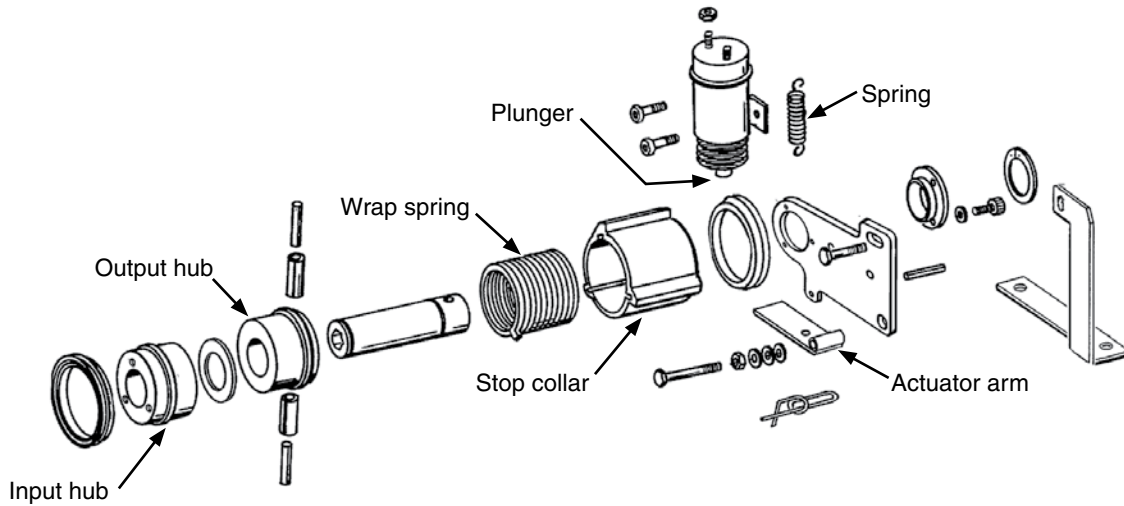

Single point row clutch main parts

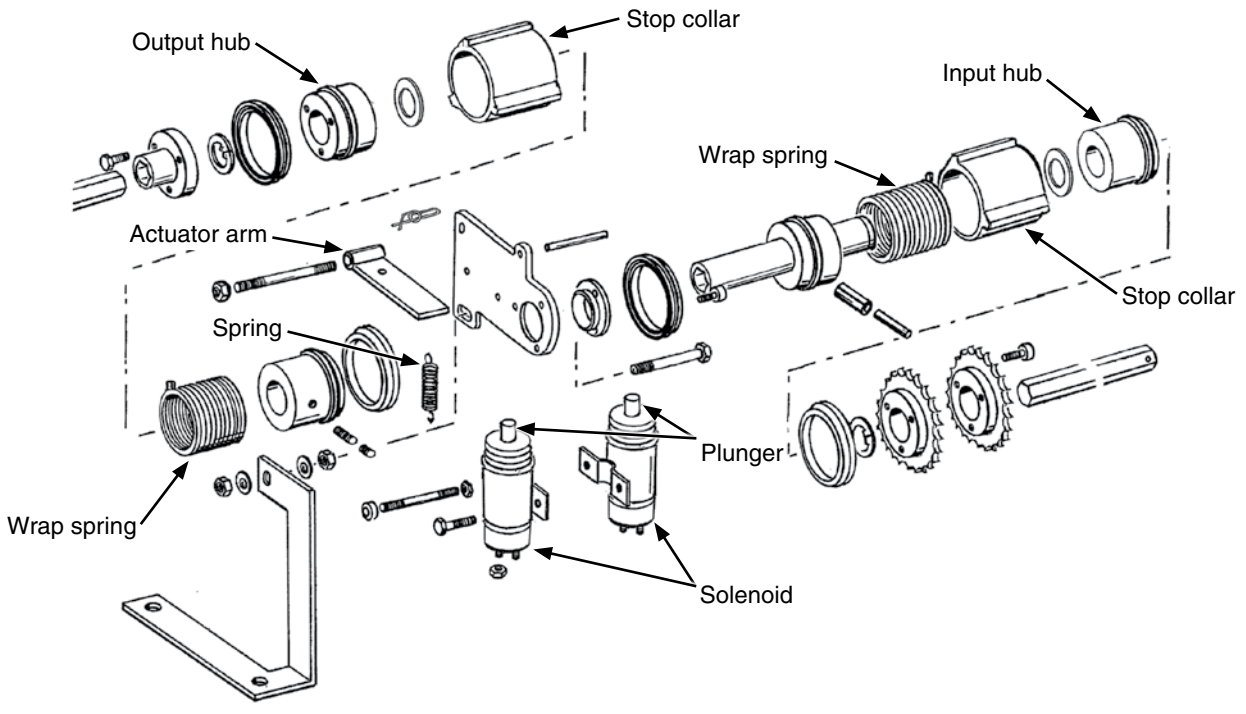

Two-speed point row clutch main parts

TESTING AND FUSE REPLACEMENT

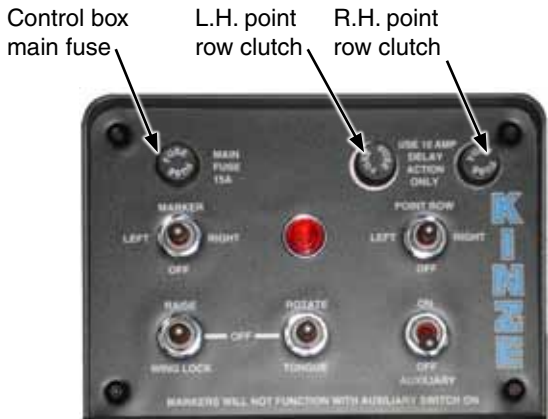

Single speed point row clutch control box (Front View)

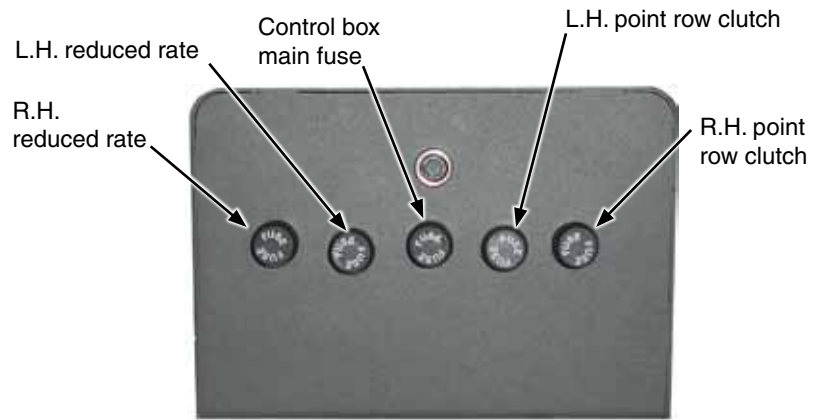

Two-speed point row clutch control box (Rear view)

**NOTE: Replace all point row fuses with MDL 10 amp slow blow fuses.**

If the clutch or clutches fail to operate, first determine if problem is electrical or mechanical.

Place operation switch in RIGHT or LEFT position. Solenoid plunger will retract causing a clicking sound if it is operating properly. Touch plunger with a metal object to check if it is electrically magnetized. Check clutch and wiring harness for power with a test light or volt meter.

**NOTE: R.H. clutch operates clockwise and L.H. clutch operates counterclockwise. Clutch parts such as the wrap spring are side specific. Use correct repair part if a clutch must be repaired.**

Also see "Point Row Clutch Troubleshooting" in Troubleshooting section.

ACTUATOR ARM ADJUSTMENT

Gap between actuator arm and stop on stop collar should be  $\frac{1}{8}$ " ( $\pm\frac{1}{32}$ ") when solenoid is NOT engaged.

Loosen nut on mounting pin and move pin in slot until there is a  $\frac{1}{8}$ " ( $\pm\frac{1}{32}$ ") gap between arm and stop on stop collar. Retighten nut.

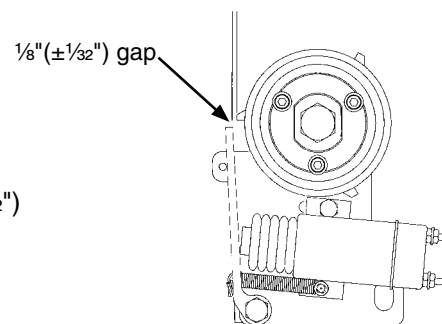

## PLANTER MOUNTED PUMP DRIVE AND OIL COOLER



Oil filter location



Oil cooler location

### NOTICE

Clean and grease PTO shaft coupling with high-pressure industrial coupling grease (Chevron® coupling grease or equivalent) meeting AGMA CG-1 and CG-2 Standards each time driveshaft is installed or premature wear and equipment failure can occur.

**NOTE: Periodically check and clean oil coolers.**

1. Replace 10-micron spin-on filters on each wing annually.
2. Fill system with SAE 10W-20 multigrade wide temperature range transmission hydraulic fluid. Reservoir capacity is approximately 10 gal (37.8L).
3. Start system and run with tractor at idle and fans turned off for 1-2 minutes. Switch fans to full speed and run with tractor at idle for 1-2 minutes.
4. Check reservoir fluid level and fill as required. Hydraulic fluid level should be within 1"-2" from top of reservoir after pump has run and hydraulic hoses have been primed to allow fluid to expand when heated.

## DIGITAL VACUUM GAUGE ADJUSTMENT

Digital vacuum gauge is factory calibrated. However, vacuum varies throughout manifold system and it may be necessary to adjust digital readout to match actual vacuum at meter.

Load seed discs with seed and compare digital vacuum gauge readouts to reading taken from analog gauges or a hand held gauge at several meters along length of planter. Elbow connections located on covers of seed meters allow testing of meter vacuum levels without removing vacuum hoses.



EdgeVac digital vacuum gauge

If there is more than 1" or 2" (H<sub>2</sub>O) difference, adjust digital gauge by inserting a small flat bladed screwdriver into opening on back of digital gauge housing and turning potentiometer until digital gauge displays vacuum present at meter. Compare readings at 10" and 20" of vacuum.

## CHECK VALVE

A check valve is located in each vacuum fan motor block assembly and operates as a return line check to prevent vacuum fan motor reverse operation. Check valves are also located in valve block on left wing and trap oil flow in planter's lift system to keep toolbar level during field operation. Another check valve is located in junction block on left wing of planter on 24 Row 30" and 36 Row 20" sizes. Remove and inspect valve. If it does not operate properly. Check for foreign material and if O-ring is leaking internally. Replace if defective.

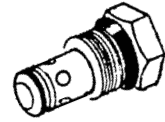

## DENTENT LEVER VALVE

Detent lever valve, located near tower assembly on R.H. side of machine, blocks oil flow from master cylinders until slave cylinders are at same height as master cylinders when planter is being lowered from transport into field position. Contact your Kinze Dealer for service.

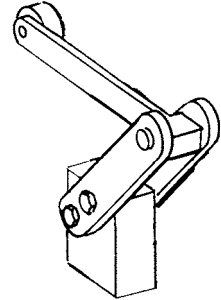

## FLOW CONTROL VALVES

Two flow control valves are located in valve block on right wing of planter. Flow control valves should be adjusted for row marker raise and lower speed as part of assembly procedure or upon initial operation. If valve fails to function properly or requires frequent adjustment, it should be removed for inspection. Check for foreign material and contamination on valve and seating areas of valve body. Replace defective components.

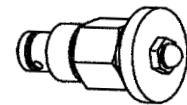

## PRESSURE RELIEF VALVES

Pressure relief valve in valve block on left wing of planter functions during lowering out of raised transport sequence. Valve is factory set and should require no additional adjustment. Pressure relief valve located in valve block on tongue functions during tongue extend cycle. This pressure relief valve ensures latch cylinder extends and releases prior to tongue extending. Valve is factory set and should require no additional adjustment. Contact your Kinze Dealer for service.

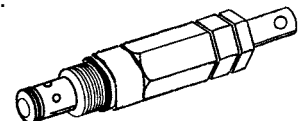
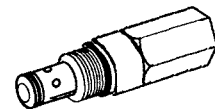

### NOTICE

**Connect hydraulic motor case drain to a case drain return line with zero pressure on tractor or hydraulic motor will be damaged. DO NOT connect hydraulic motor case drain to SCV outlet. Contact tractor manufacturer for specific details on "zero pressure return".**

## RELIEF VALVE CARTRIDGE

Pressure relief valve located in vacuum fan motor block assembly helps prevent damage to vacuum fan motor by limiting pressure in the motor case drain line. It is set to open at 35 PSI. If valve fails to function properly, it should be removed for inspection. Check for foreign material and contamination on valve and the seating area of valve body. Replace if defective.

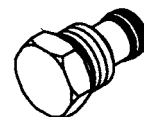

## SOLENOID VALVE

Solenoid valve consists of a chambered body with an electric coil actuated cartridge valve.

If solenoid or solenoids fail to operate, first determine if problem is electrical or hydraulic. If valve is working properly, a click will be heard when solenoid coil is energized and valve stem opens. If no sound is heard, check solenoid coil by touching top of coil housing with a metallic object such as a pliers or screwdriver. If coil is working properly, coil housing will be strongly magnetized when energized. If voltage to coil is low it will be weakly magnetized when energized and no click will be heard.

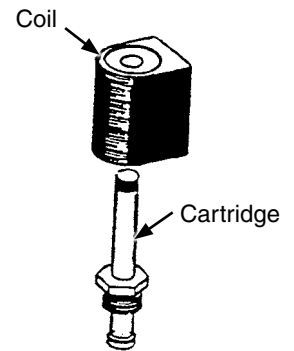

## STROKE LIMITER VALVE

Stroke limiter valve, located near tower assembly on L.H. side of machine, limits height planter will raise during turn around when planter is in field operation. Contact your Kinze Dealer for service.

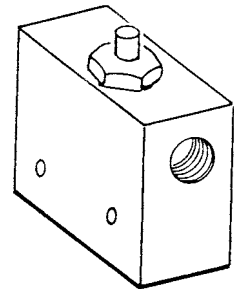

## CHAIN TENSION ADJUSTMENT

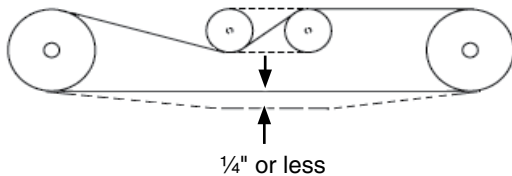

Chain link storage location (each wing)

Most drive chains have a spring loaded idler and are self-adjusting. The only adjustment needed is to shorten chain if wear stretches chain and reduces spring tension. Check idler pivot point periodically to ensure they rotate freely.

On chains with slotted idlers for adjustment, adjust so chain has 1/4" or less sag at longest span. See "Wrap Spring Wrench Assembly" for additional information.

Additional chain links can be found in the storage area located at end of planter frame on inboard side of transport hook.

## STROKE LIMITER (HEIGHT STOP) VALVE ADJUSTMENT

Field turn around height of toolbar should measure 39"-41" from ground if stroke limiter valve is correctly adjusted.

1. Lower planter to ground and hold hydraulic lever for 15-20 seconds to purge air and rephase system.

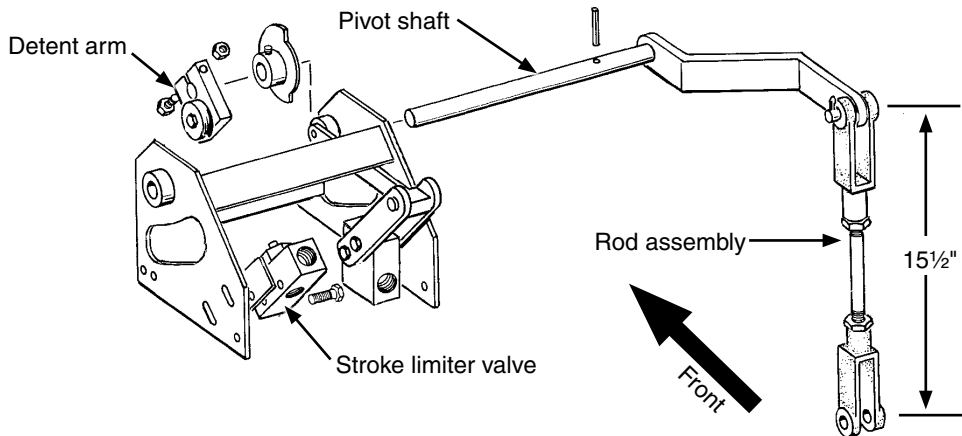

2. Check rod assembly adjustment bolt is set at  $15\frac{3}{4}$ " pin to pin when planter is fully lowered. Adjust as needed.

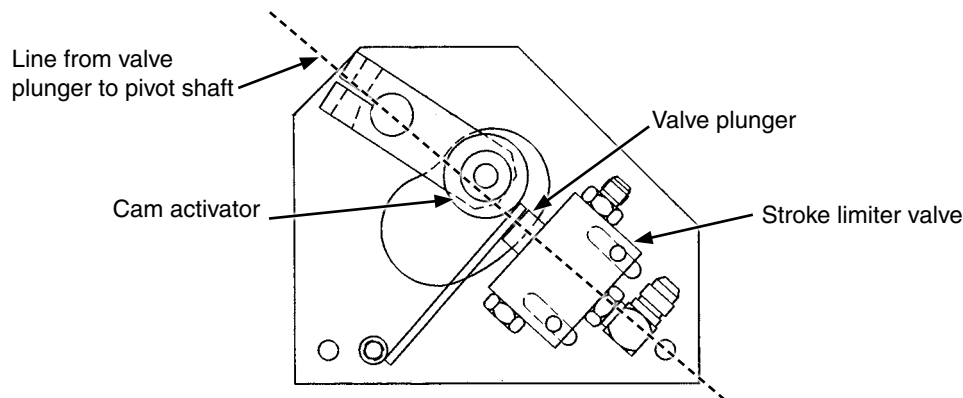

3. Check stroke limiter (height stop) valve plunger is depressed and pointing in a straight line to center of pivot shaft on cam activator.
4. Loosen detent arm (height stop assembly) clamping bolt and rotate detent arm over depressed stroke limiter valve plunger. Valve plunger should be fully depressed when detent arm is rotated over plunger arm, but must not bind. If binding occurs, move valve assembly away from detent arm while keeping valve plunger aligned with pivot shaft. Slide stroke limiter valve up or down in slotted mounting holes as needed to adjust. Tighten stroke limiter valve mounting bolts and recheck adjustment. Be sure detent arm is positioned as shown and tighten detent arm clamping bolt.
5. Raise planter until stroke limiter valve (height stop assembly) halts lift cylinder. Toolbar should measure 39"-41" from ground. If adjustment is needed, loosen detent arm clamping bolt and rotate detent arm counterclockwise to reduce and clockwise to increase lift height. Tighten clamping bolt and mark a line on detent arm and cam activator shaft for easier alignment later.

**NOTE: When lowering from transport position, planter toolbar should level out to a height of 39"-41" from ground at field turn around. If it doesn't, rephase and/or remove air from the hydraulic lines and recheck toolbar height. Repeat above adjustments as needed.**

## DETENT LEVER (LOWERING CONTROL) VALVE ADJUSTMENT

Center of planter should drop until toolbar is level and then entire planter should lower evenly when lowering planter for field operation from transport position if detent lever valve is correctly adjusted.

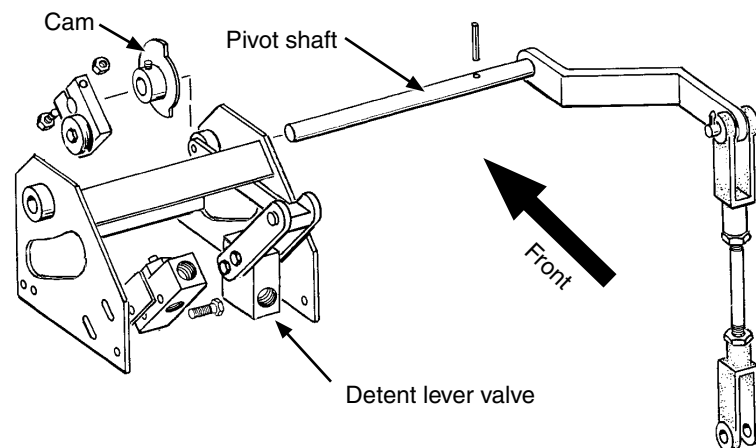

1. Lower planter to field turn around position and check toolbar height is 39"-41". Adjust following procedure for stroke limiter valve adjustment. Stroke limiter (height stop) valve must be correctly adjusted prior to adjusting detent lever (lowering control) valve.

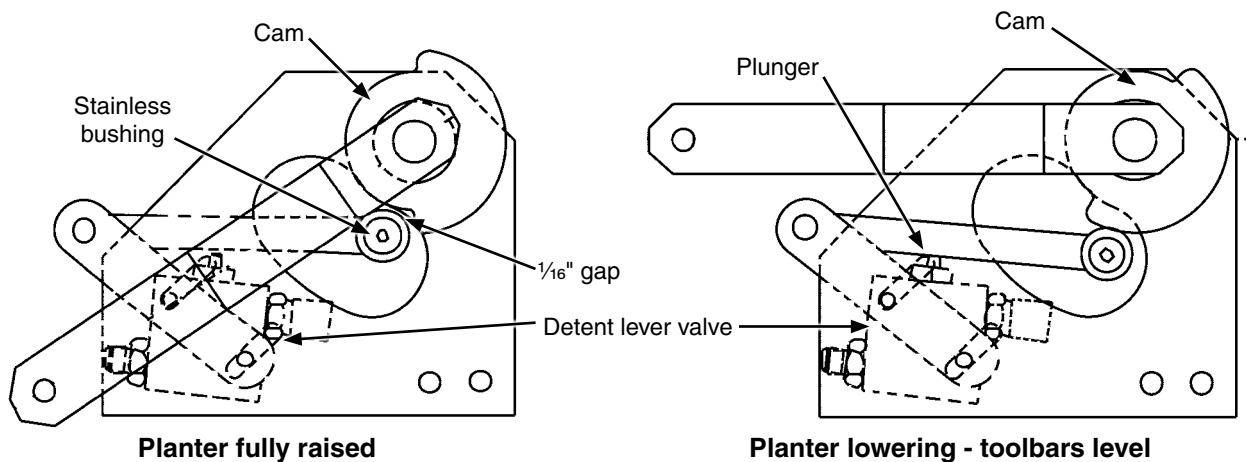

2. Raise planter to fully raised position. With cam positioned as shown, adjust detent lever (lowering control) valve in its mounting slots so there is  $\frac{1}{16}$ " gap between stainless bushing and cam. Lower edge of cam must be above pivot point of stainless bushing.

**NOTE: While lowering planter, center cylinders should begin to retract while wing cylinders stay extended. When toolbar becomes level, large radius of cam should cause arm to depress plunger on detent lever valve allowing wing cylinders to start retracting.**

3. Lower planter. If center of planter drops lower than wings, loosen set screws and rotate cam clockwise. If wing cylinder begins to retract too early and wings drop lower than center of planter, rotate cam counterclockwise. Adjust cam with planter in raised position.
4. After final adjustment, remove one set screw and drill a depression in cam activator shaft with a  $\frac{1}{4}$ " drill bit. Replace set screw and repeat with second set screw.

## ROW MARKER BEARING LUBRICATION OR REPLACEMENT

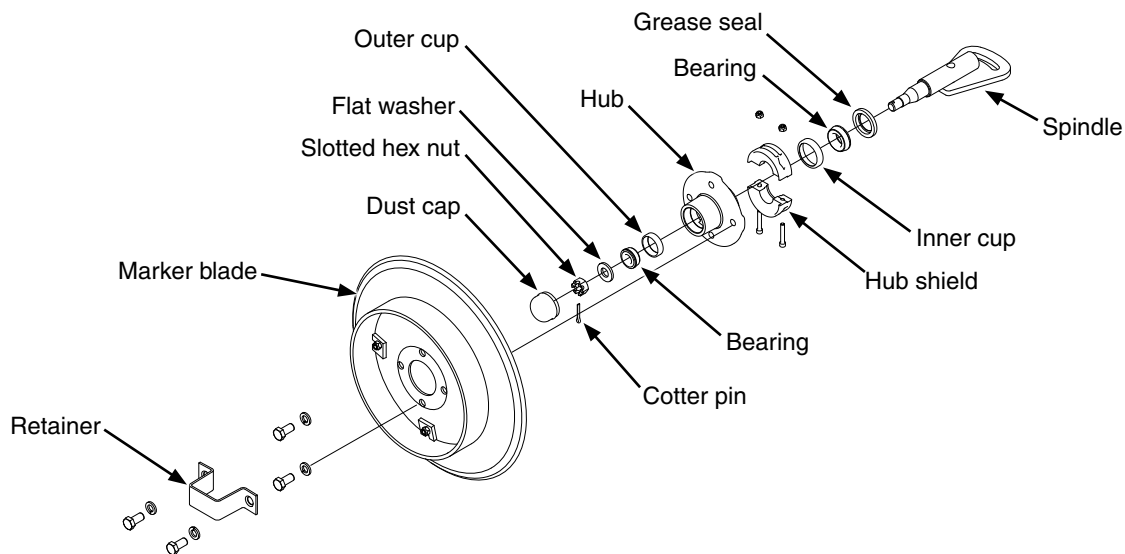

1. Remove retainer and marker blade.
2. Remove dust cap from hub.
2. Remove hub shield. Note direction of installation.
3. Remove cotter pin, slotted hex nut, and washer.
4. Slide hub from spindle.
5. Remove bearings and cups and discard if bearings are being replaced. Clean hub and dry. Remove bearings only and not cups if repacking.
6. Press in new bearing cups with thickest edge facing in. (Bearing replacement procedure only.)
7. Pack bearings with heavy duty wheel bearing grease thoroughly forcing grease between roller cone and bearing cage. Fill the space between the bearing cups in the hub with grease.
8. Install rubber seal into grease seal. Place inner bearing in place and press in new rubber seal/grease seal.
9. Clean spindle and install hub.
10. Install outer bearing, washer and slotted hex nut. Tighten slotted hex nut while rotating hub until there is some drag. This ensures all bearing surfaces are in contact. Back off slotted nut to nearest locking slot and install cotter pin.
11. Fill dust caps approximately  $\frac{3}{4}$  full of wheel bearing grease and install on hub.
12. Install hub shield.
13. Install marker blade and retainer on hub. Tighten hardware evenly.

**This page left blank intentionally.**

**! WARNING**

Uncontrolled machine movement can crush or cause loss of control resulting in death, serious injury, or damage to property and equipment. Install all safety lockup devices before working under or transporting this equipment.

**LIFT/GROUND DRIVE WHEEL BEARING REPACK OR REPLACEMENT**

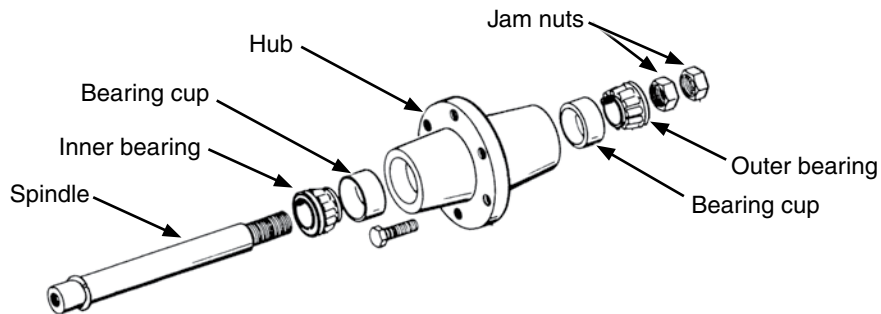

1. Raise tire clear of ground and remove wheel.
2. Remove double jam nuts and slide hub from spindle.
3. Remove bearings and cups and discard if bearings are being replaced. Clean hub and dry. Remove bearings only and not cups if repacking.
4. Press in new bearing cups with thickest edge facing in. (Bearing replacement procedure only.)
5. Pack bearings with heavy duty wheel bearing grease thoroughly forcing grease between roller cone and bearing cage. Fill space between bearing cups and hub with grease.
6. Place inner bearing in place.
7. Clean spindle and install hub.
8. Install outer bearing and jam nut. Tighten jam nut while rotating hub until there is some drag. This ensures all bearing surfaces are in contact. Back off jam nut ¼ turn or until there is only slight drag when rotating hub. Install second jam nut to lock against first.
9. Install wheel on hub. Tighten hardware evenly.

**⚠ WARNING**

Uncontrolled machine movement can crush or cause loss of control resulting in death, serious injury, or damage to property and equipment. Install all safety lockup devices before working under or transporting this equipment.

## TRANSPORT WHEEL BEARING REPLACEMENT

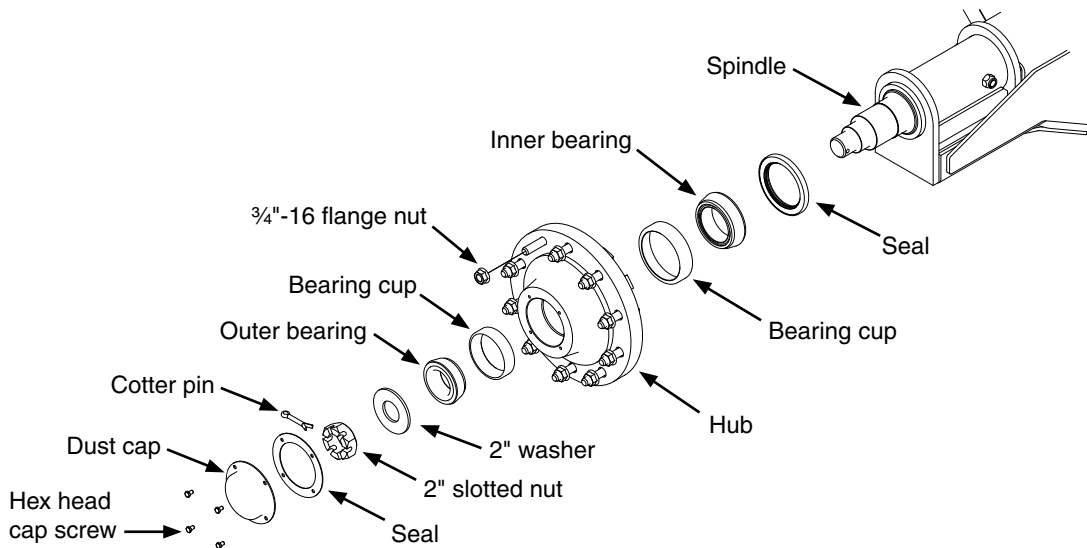

1. Raise tires clear of ground and support with jack stand. Remove wheels.
2. Remove dust cap attachment hardware and cap from wheel hub.
3. Remove cotter pin, slotted nut, and 2" washer.
4. Slide hub from axle spindle. Use a hub puller if necessary.
5. Remove bearings and cups from hub and discard. Thoroughly clean and dry wheel hub.
6. Press in new bearing cups with thickest edges facing in.
7. Pack bearing with heavy-duty wheel bearing grease. Thoroughly force grease between roller cone and bearing cage. Fill space between bearing cups and hub with grease.
8. Place inner bearing in hub and press in new grease seal with lip pointing towards bearing.
9. Clean axle spindle and install hub.
10. Install outer bearing, 2" washer, and slotted nut. Tighten slotted nut while rotating hub until there is some drag. This ensures all bearing surfaces are in contact. Back off slotted nut to nearest locking slot and install cotter pin. Check bearing endplay.
11. Fill dust cap half full of wheel bearing grease and install on hub with four hex head cap screws.
12. Install wheels and remove jack stand. Torque  $\frac{3}{4}$ " flange nuts to 280 ft-lb (379.6 N-m).

## FERTILIZER CHECK VALVE CLEANING AND REPAIR

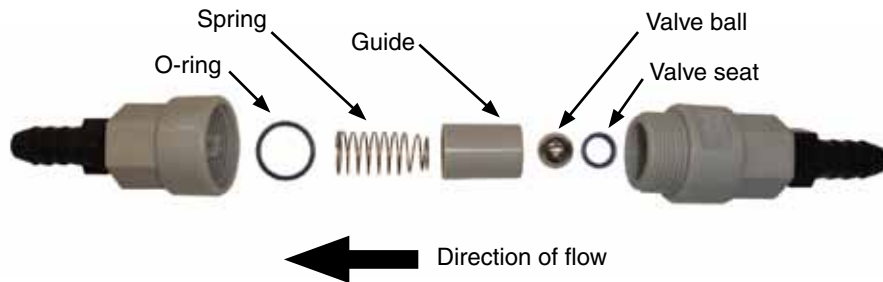

1. Unscrew valve body and separate halves. Note direction and location of parts.
2. Clean and inspect parts. Flush with clean water. Replace damaged parts.
3. Reassemble exactly as shown. O-ring and valve seat must be firmly in place inside each half of valve body.

## PISTON PUMP STORAGE

### **NOTICE**

**Entrance of air into pump will cause rapid and severe corrosion.  
KEEP AIR OUT OF PUMP!**

**NOTE: SUSPENSION FERTILIZER must be flushed from pump for ANY storage period.**

1. Flush pump with 5 to 10 gallons of fresh water and circulate until all corrosive salts are dissolved in pump.
2. Set pump on 10. Draw in a mixture of half diesel fuel and 10 weight oil until discharge is clean. Plug inlet and outlet.

## PREPARATION FOR STORAGE

Store planter in a dry sheltered area if possible.

Remove all trash wrapped on sprockets or shafts and remove dirt that can draw and hold moisture.

Clean all drive chains and coat with a rust preventative spray, or remove chains and submerge in oil.

Lubricate planter and row units at all lubrication points.

Inspect planter for parts that in need of replacement and order during “off” season.

Make sure all seed and granular chemical hoppers are empty and clean.

Remove seed discs from seed meters, clean and store meters in a rodent-free, dry area with discs removed. Store seed discs vertically on a dowel or pipe.

Remove vacuum hose from each seed meter. Operate vacuum fan at full hydraulic flow from tractor for two minutes to clear manifolds, hoses and fittings of dust and debris.

Clean breather on analog vacuum and pressure gauges.

Disassemble, clean and grease all U-joint slides.

Grease or paint disc openers/blades and row marker disc blades to prevent rust.

Flush liquid fertilizer tanks, hoses and metering pump with clean water. See “Piston Pump Storage” if applicable.

Empty dry fertilizer hoppers. Clean hoppers. Disassemble and clean metering augers. Reassemble, coating all metal parts with rust preventative.

ASD System:

- Clean out ASD hopper, entrainment assembly, and delivery hoses.
- Disconnect delivery hoses from entrainer ports. Install small orange caps onto ports. Attach hoses to caps.
- Disconnect delivery hoses from air dissipator at each row unit. Install large orange caps. Attach hoses to caps.
- Check all bolts and fasteners used to assemble and attach entrainment device are tight (if applicable).
- Loosen knobs on entrainer cleanout doors to remove pressure from door gaskets.
- Inspect all seed delivery hoses and replace any that are worn, cut, or cracked.

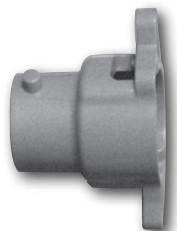

**Entrainer cap**

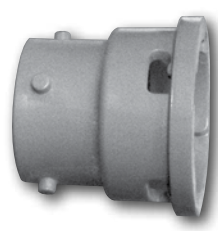

**Air dissipator cap**

**This page intentionally left blank.**

**ELECTRICAL WIRING DIAGRAM FOR LIGHT PACKAGE**

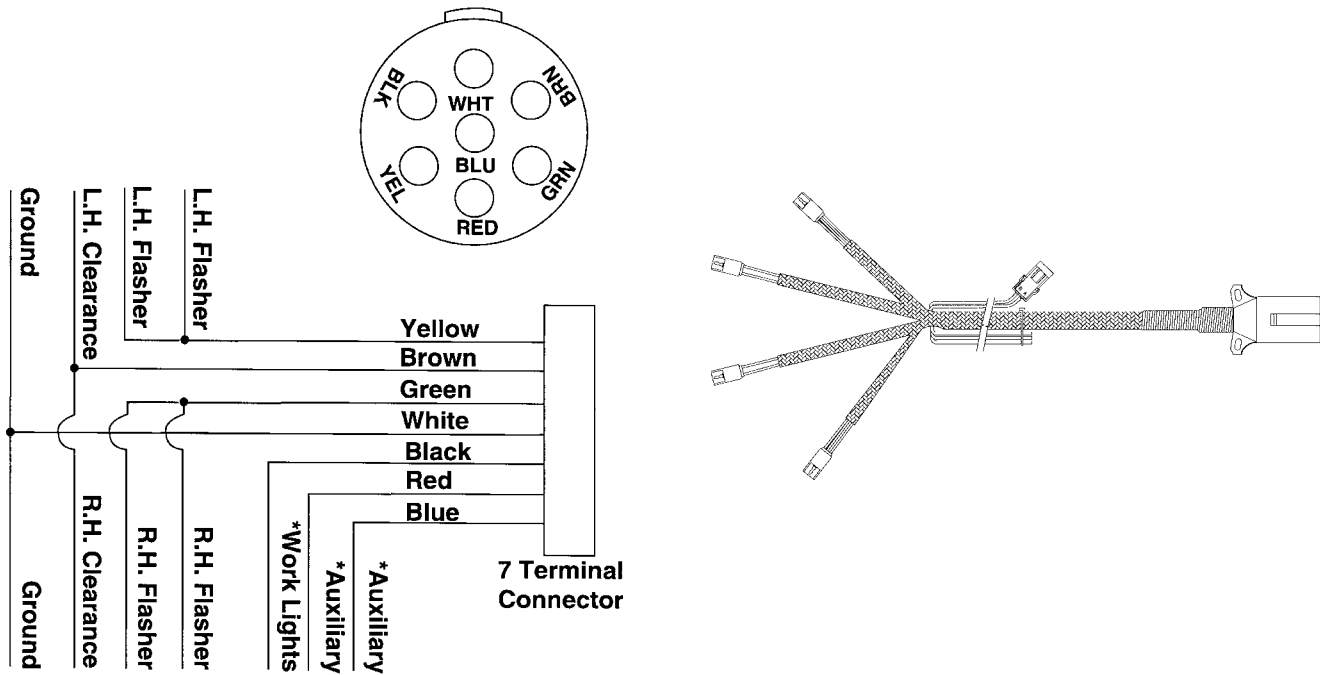

Light packages supplied on Model 3700 Front Folding Planters meet ASABE Standards. Check with tractor manufacturer for correct wiring harness to be wired into lights on your tractor, .

**\*Optional customer-supplied auxiliary lights and wires may be wired into existing plug terminals.**

**ELECTRICAL CONTROL CONSOLE SCHEMATIC**

**NOTICE**

Disconnect control console from tractor battery before doing any electrical work or shorting will damage equipment. Keep wiring harnesses away from high temperature areas or sharp edges. **DO NOT** route wiring harnesses along battery cables. Use cable ties to keep wire harness away from moving parts on tractor and planter. Ground connections to tractor frame must be clean to provide good electrical contact.

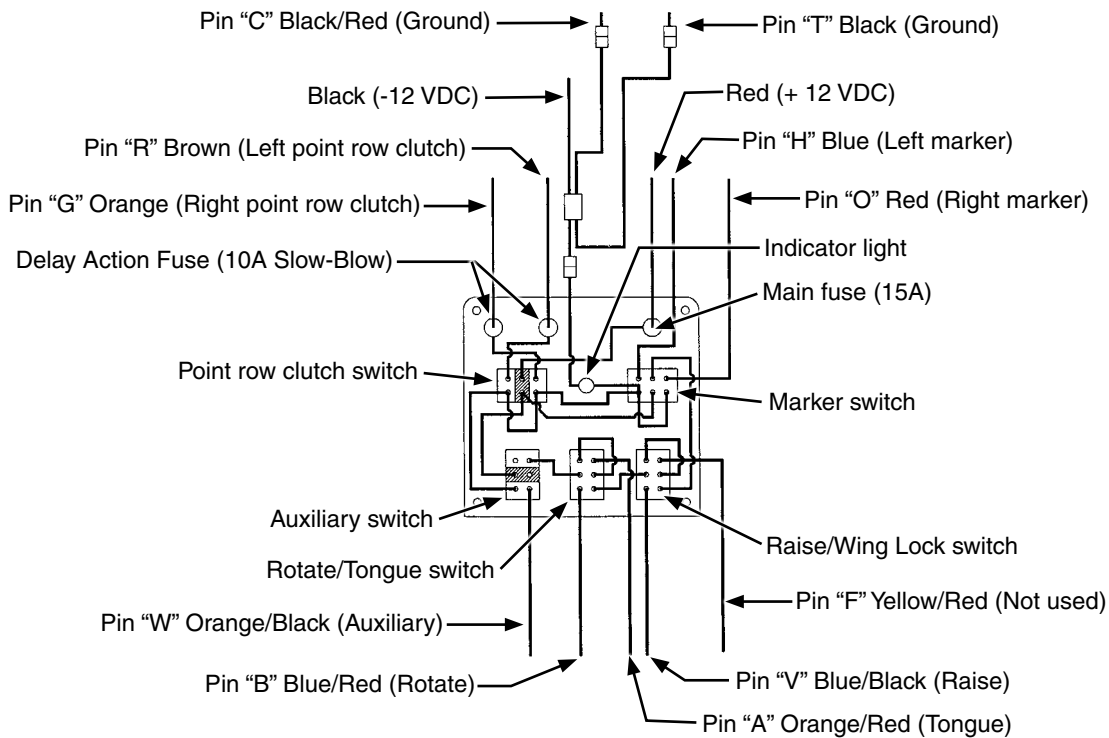
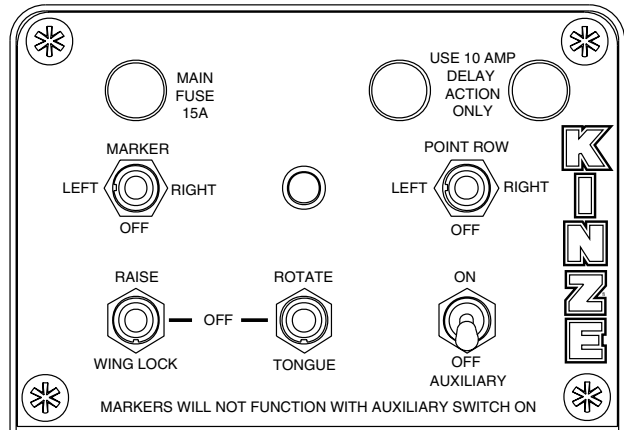

**NOTE:**

1. Operating row marker or point row switch in either direction lights panel light.
2. Point row clutch switch operates independently from rest of control box.
3. Power to row marker switch is fed through auxiliary switch and two transport function switches. Operating any switch in lower row disables row marker function and turns off panel light. (If point row clutch switch is "OFF".)
4. See page 6-41 for two-speed point row clutch electrical control console and wiring harness schematics.

**ELECTRICAL WIRING HARNESS SCHEMATIC (ON TRACTOR)**

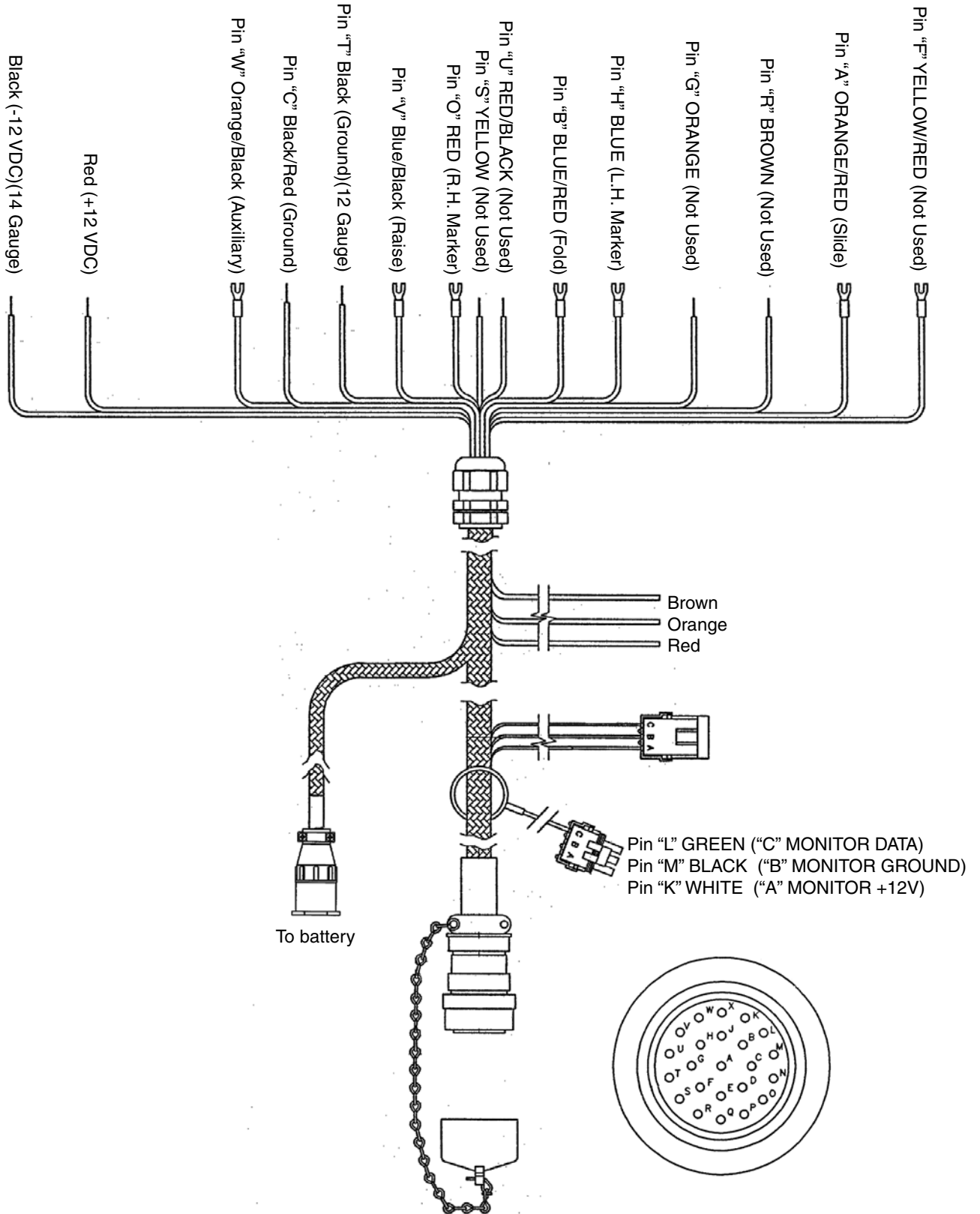

**ELECTRICAL WIRING HARNESS SCHEMATIC (ON PLANTER)**

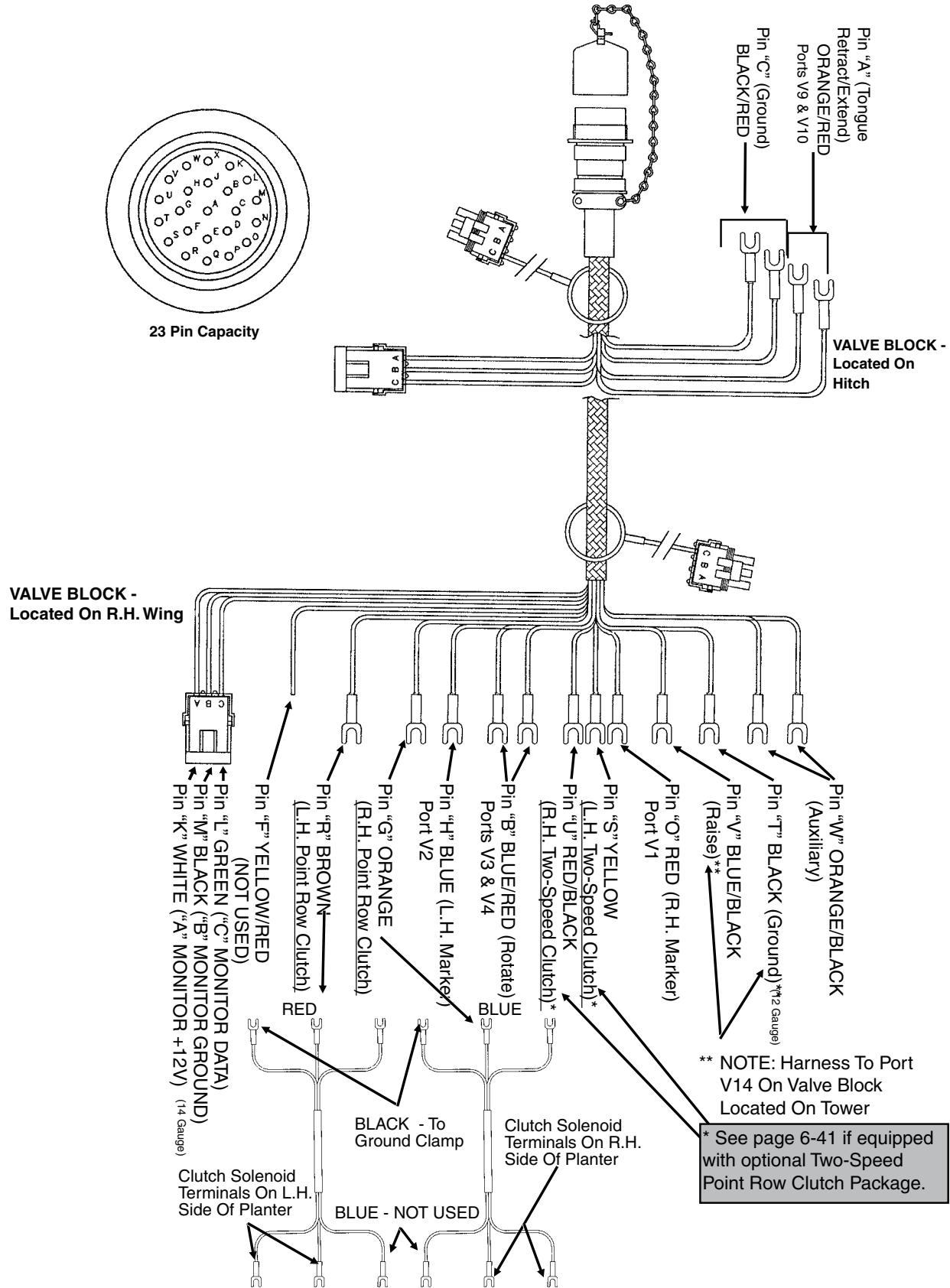

## VALVE BLOCK - LOCATED ON HITCH

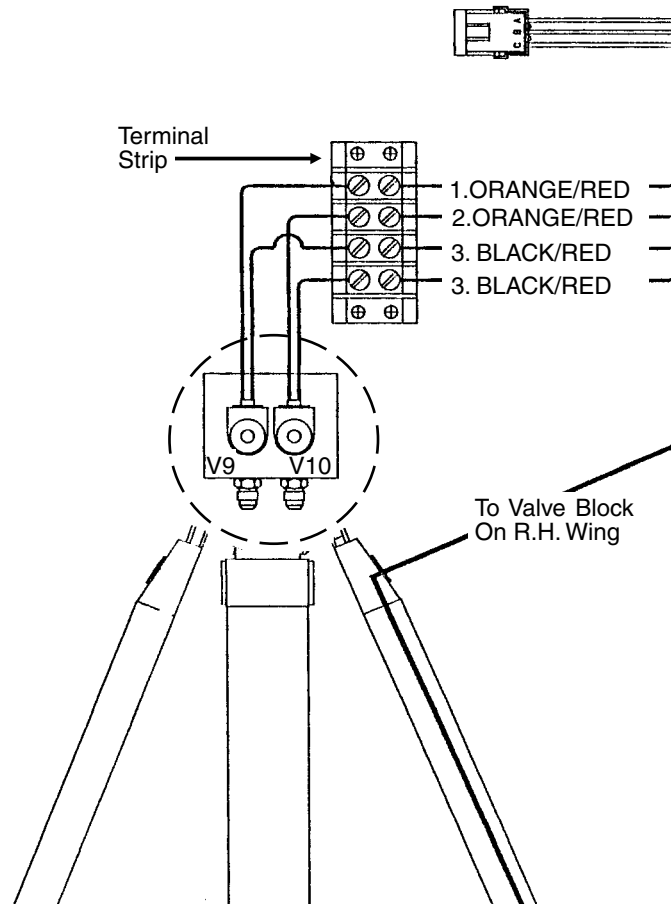

1. ORANGE/RED - Pin "A" (Tongue Retract/Extend) - Port V9
2. ORANGE/RED - Pin "A" (Tongue Retract/Extend) - Port V10
3. BLACK/RED - Pin "C" (Ground)

**VALVE BLOCKS - LOCATED ON TOWER AND R.H. WING**

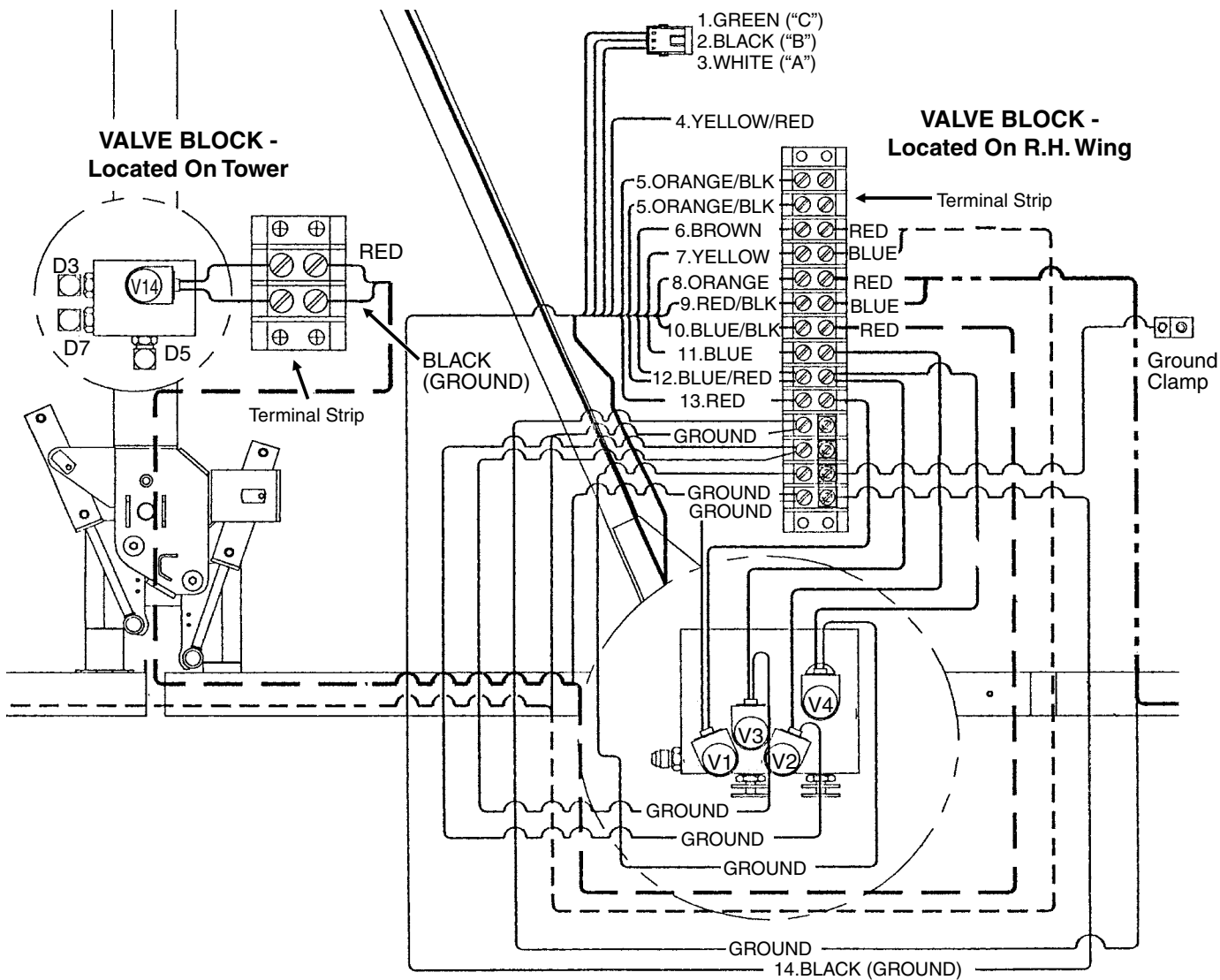

1. GREEN - Pin "L" ("C" MONITOR DATA)
2. BLACK - Pin "M" ("B" MONITOR GROUND)
3. WHITE - Pin "K" ("A" MONITOR +12V)
4. YELLOW/RED - Pin "F" (NOT USED)
5. ORANGE/BLACK - Pin "W" (Auxiliary)
6. BROWN - Pin "R" (L.H. Point Row Clutch)
7. YELLOW - Pin "S" (L.H. Two-Speed Clutch)\*
8. ORANGE - Pin "G" (R.H. Point Row Clutch)
9. RED/BLACK - Pin "U" (R.H. Two-Speed Clutch)\*
10. BLUE/BLACK - Pin "V" (Raise)
11. BLUE - Pin "H" (L.H. Marker) - Port V2
12. BLUE/RED - Pin "B" (Rotate) - Ports V3 And V4
13. RED - Pin "O" (R.H. Marker) - Port V1
14. BLACK - Pin "T" (Ground)

\* See page 6-41 if equipped with optional Two-Speed Point Row Clutch Package.

**CONTROL CONSOLE SCHEMATIC (OPTIONAL TWO-SPEED POINT ROW CLUTCHES)**

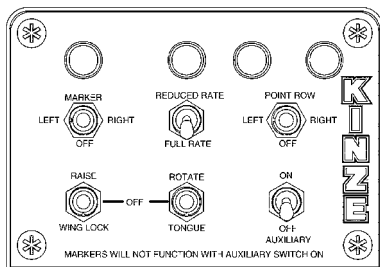
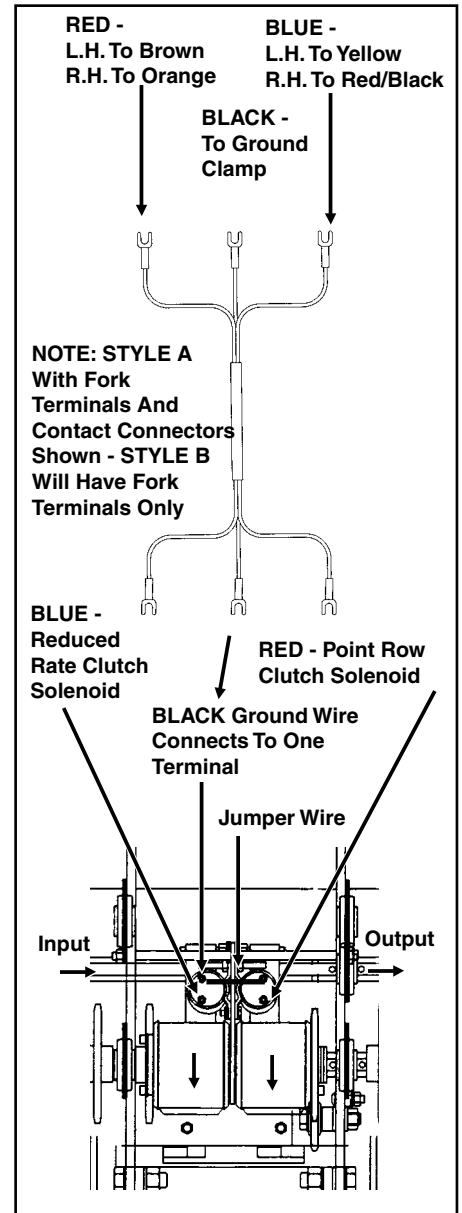
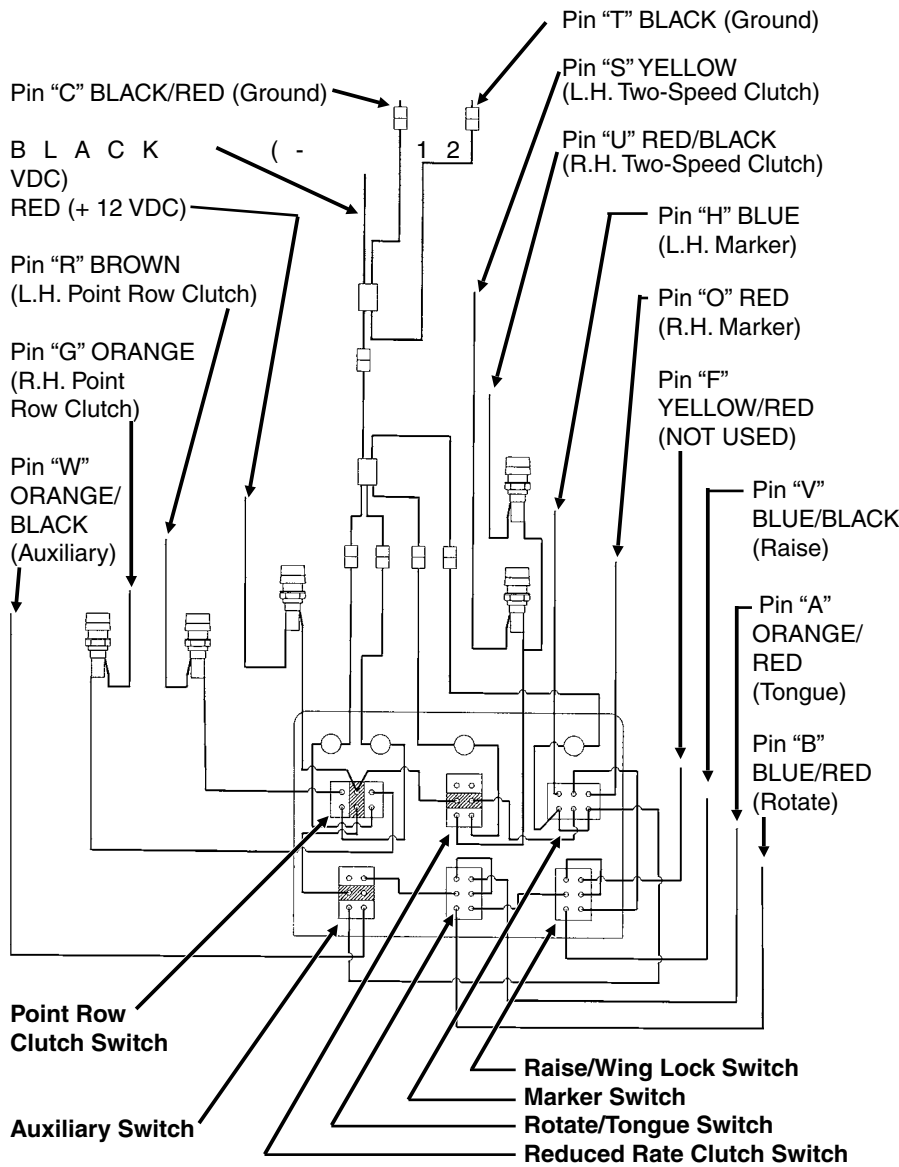

**NOTE:**

1. Point row and reduced rate clutch switches operate independently from rest of control console.
2. Power to marker switch is fed through auxiliary switch and two transport function switches. Operating any switch in lower row disables marker function and turns off panel light for markers.

**NOTICE**  
 Disconnect control console from tractor battery before doing any electrical work or shorting will damage equipment. Keep wiring harnesses away from high temperature areas or sharp edges. **DO NOT** route wiring harnesses along battery cables. Use cable ties to keep wire harness away from moving parts on tractor and planter. Ground connections to tractor frame must be clean to provide good electrical contact.

**ELECTRICAL WIRING HARNESS SCHEMATIC (VACUUM FAN CONTROL)**

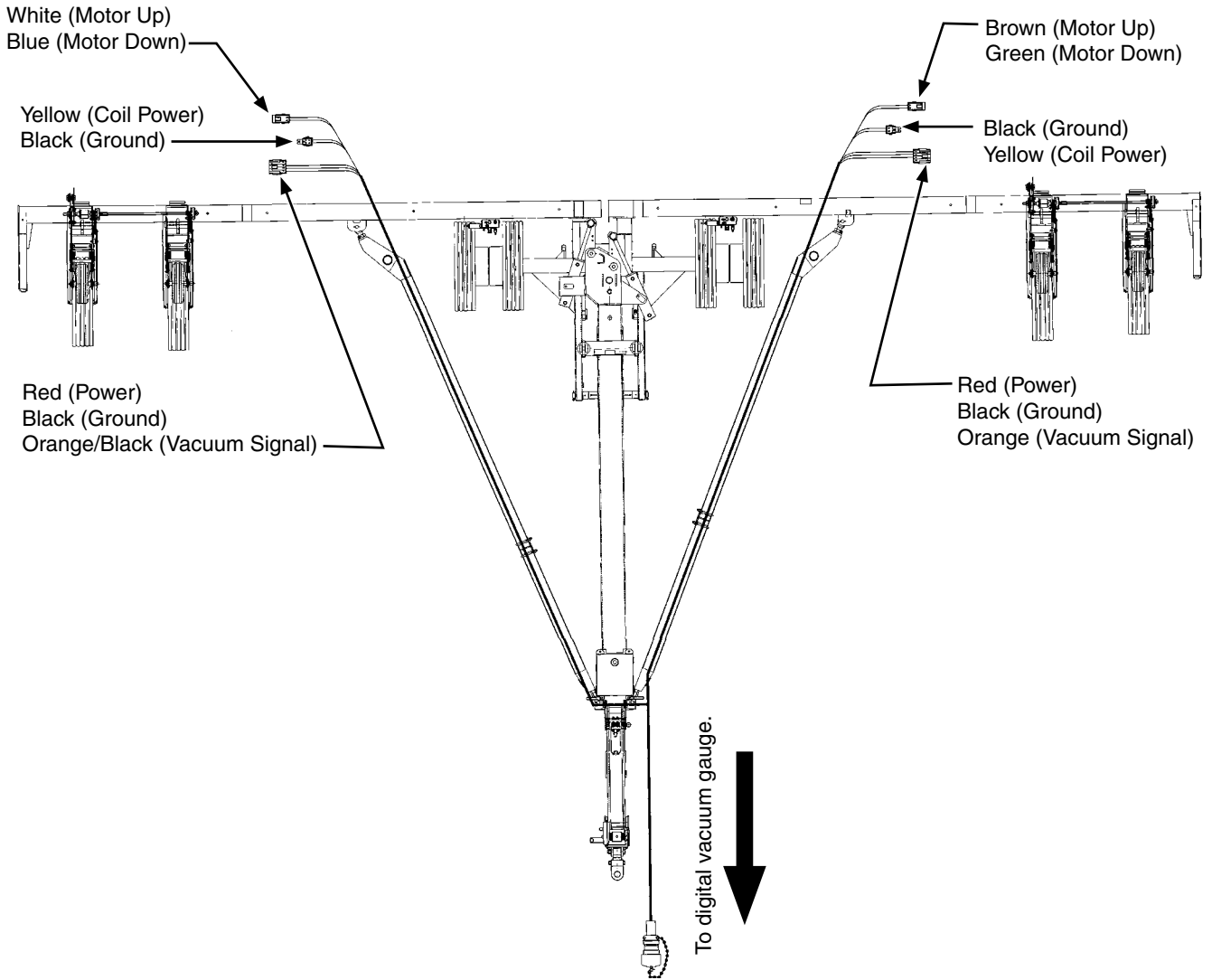

**HYDRAULIC SCHEMATIC (ASD SYSTEM)**

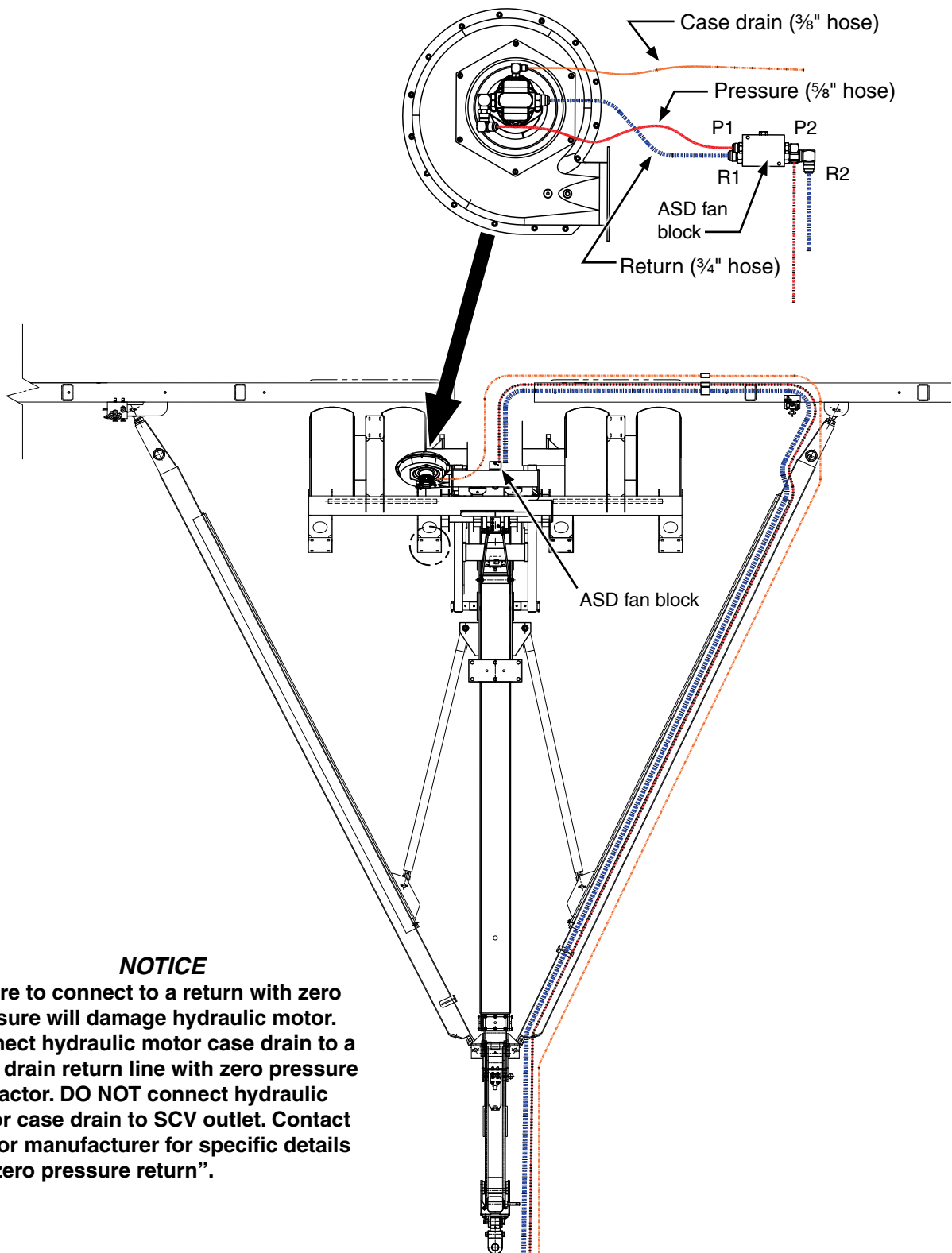

**HYDRAULIC SCHEMATIC (VACUUM FAN SYSTEM)**

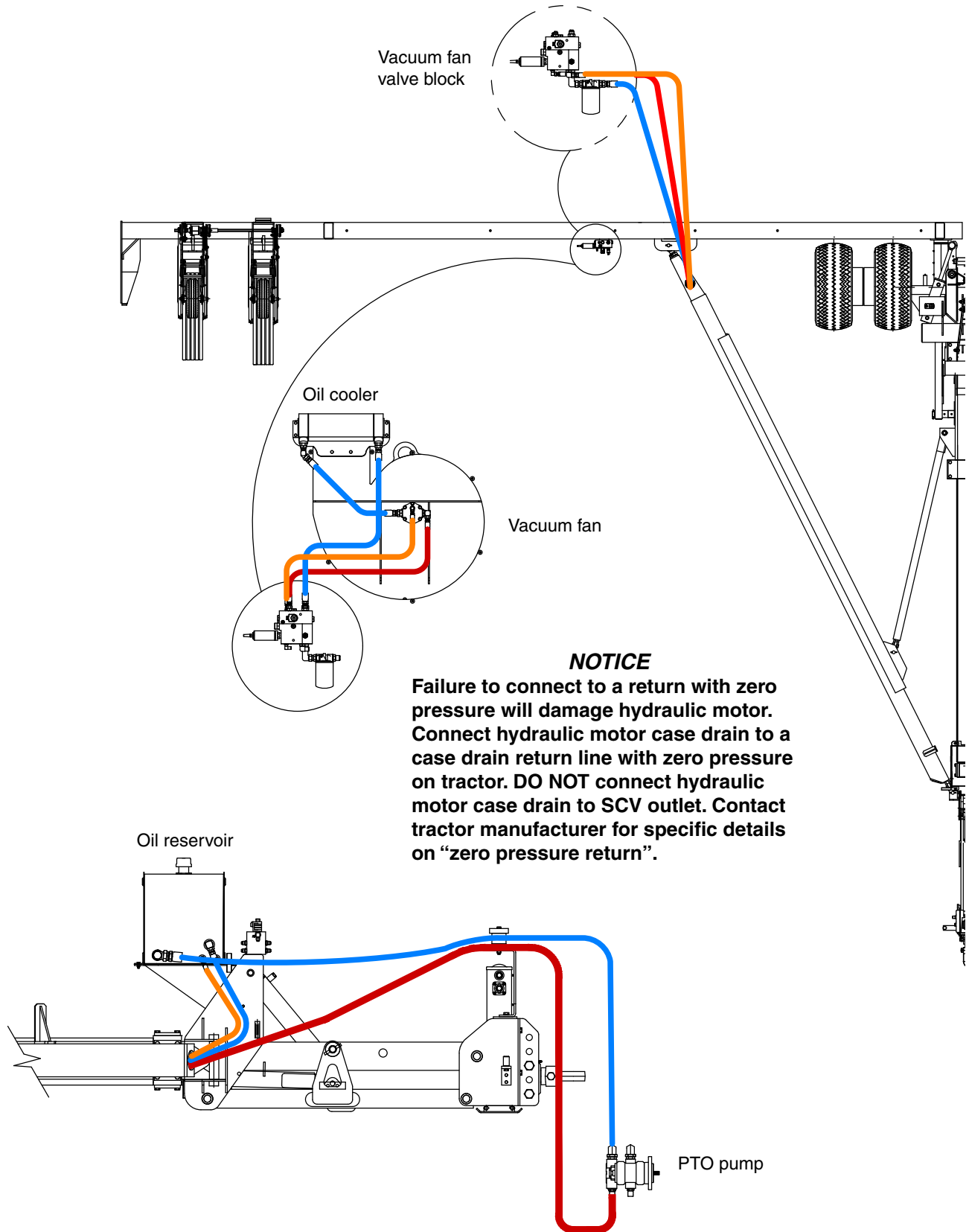

**NOTICE**

Failure to connect to a return with zero pressure will damage hydraulic motor. Connect hydraulic motor case drain to a case drain return line with zero pressure on tractor. DO NOT connect hydraulic motor case drain to SCV outlet. Contact tractor manufacturer for specific details on "zero pressure return".

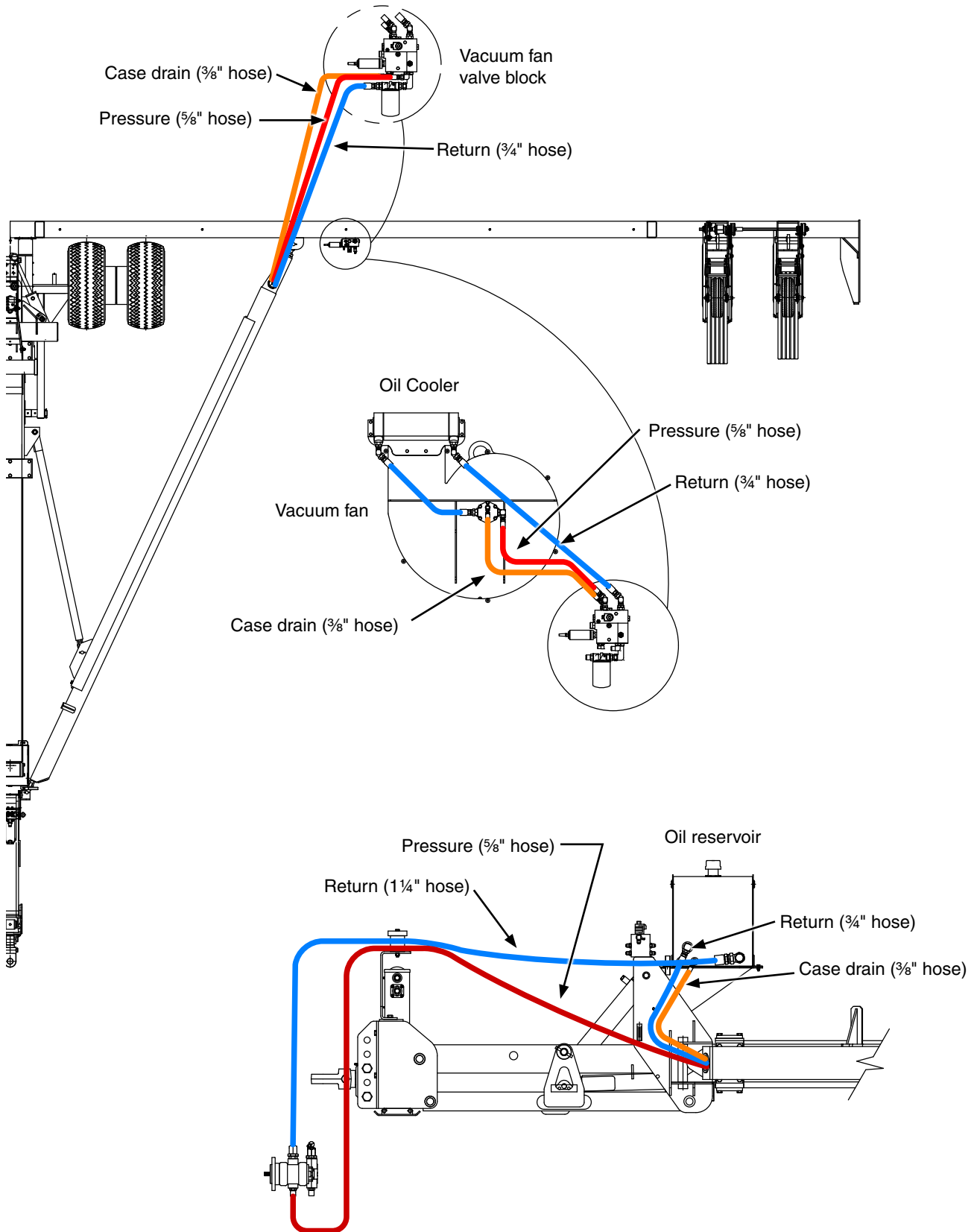

HYDRAULIC SYSTEM SCHEMATIC (24 ROW 20"/30")

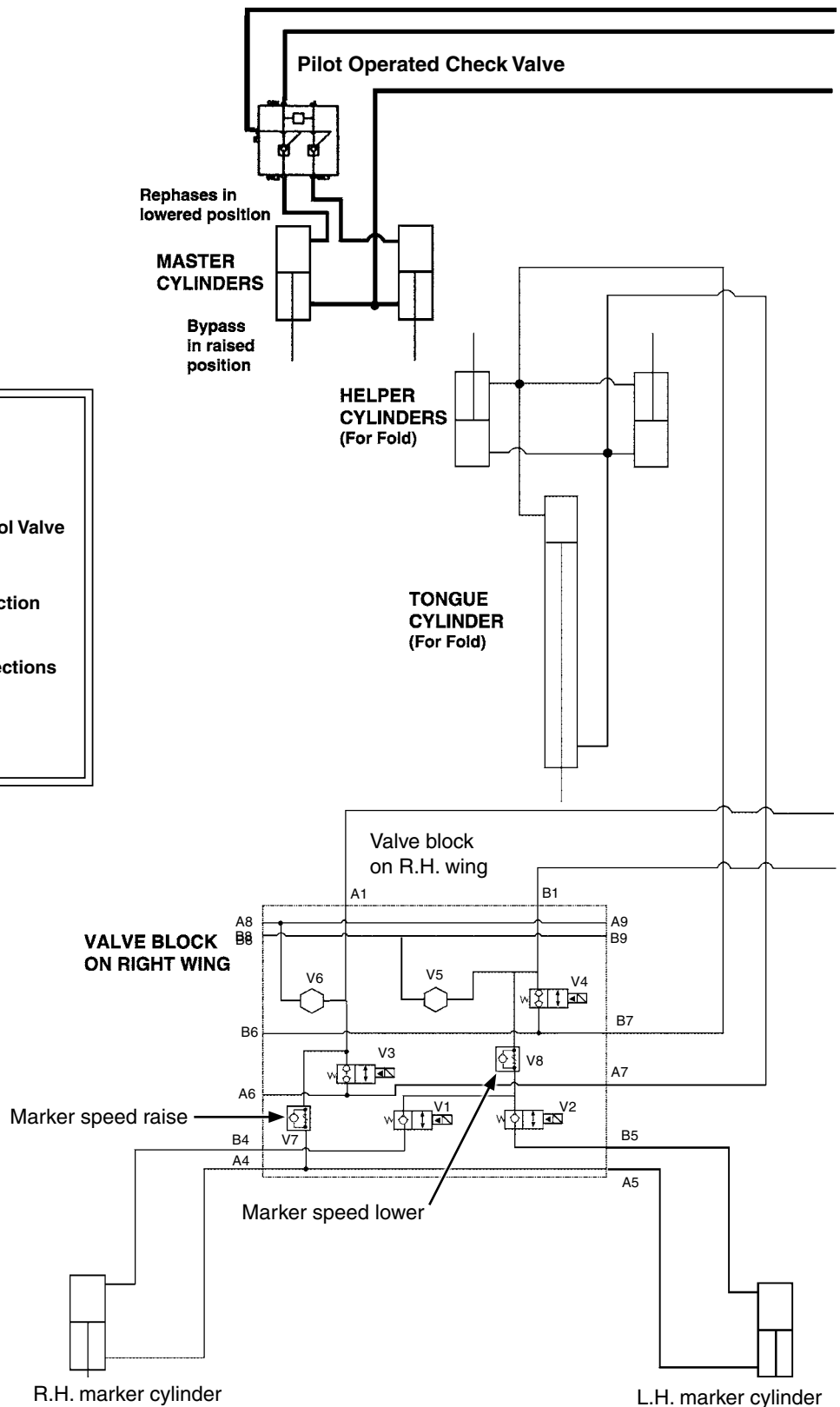
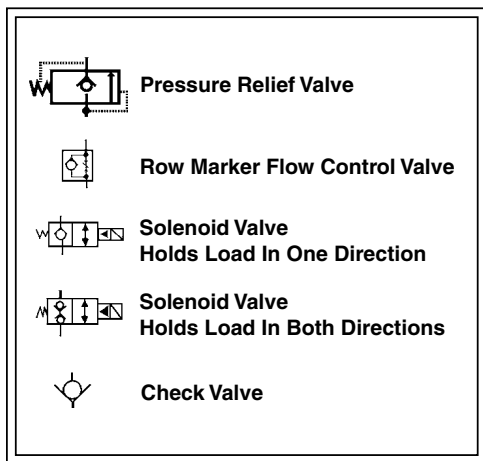

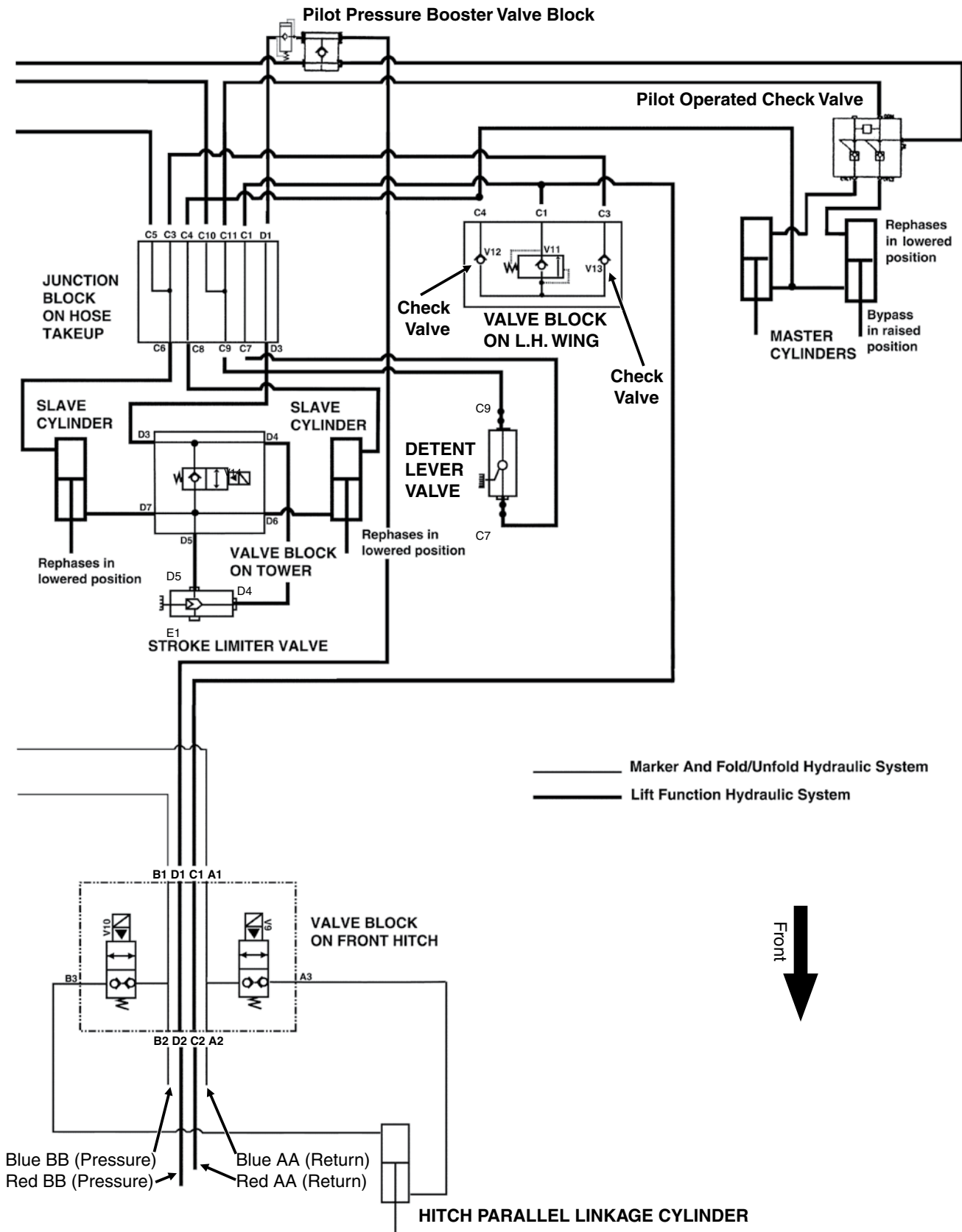

HYDRAULIC SYSTEM SCHEMATIC (36 ROW 20")

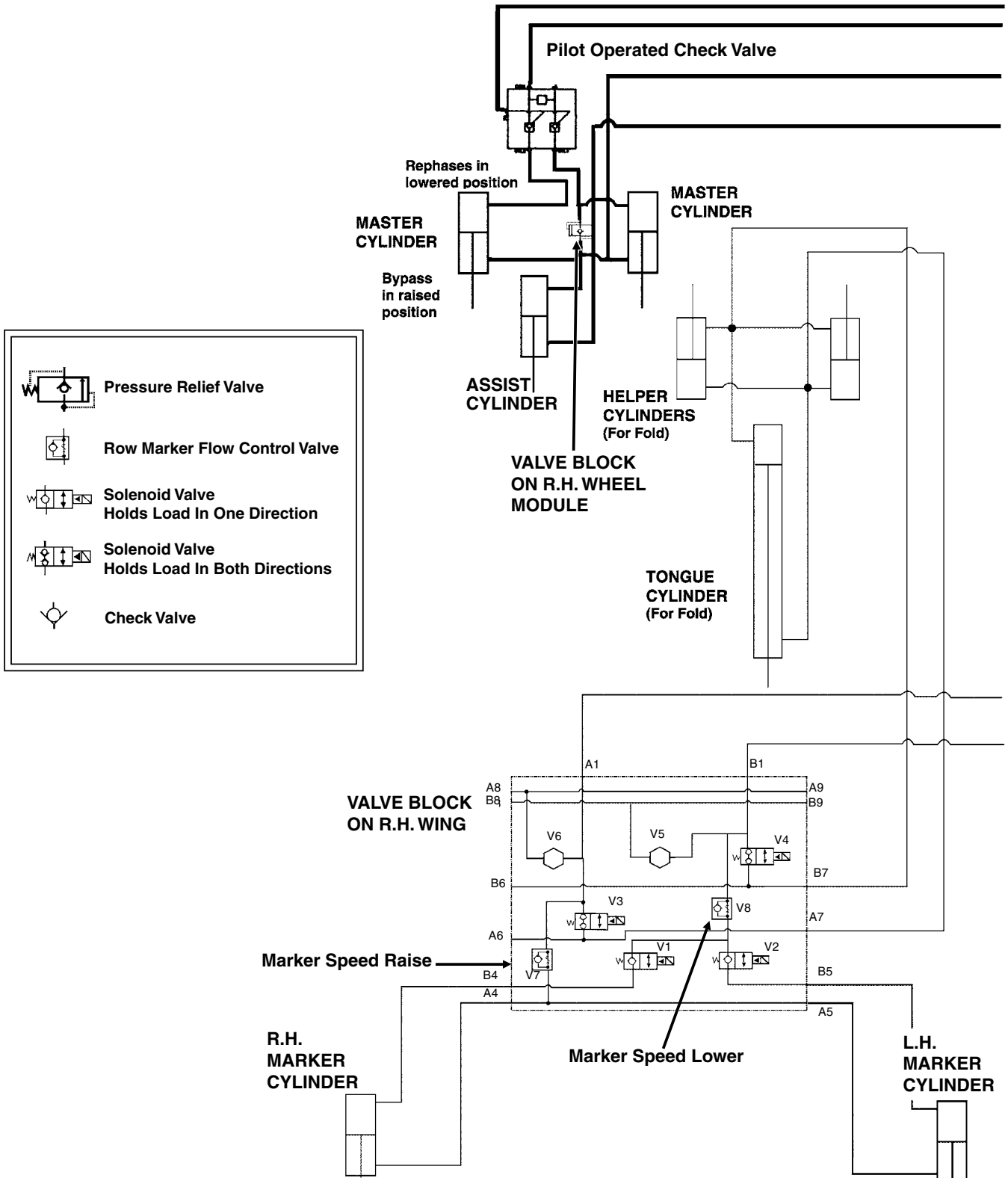

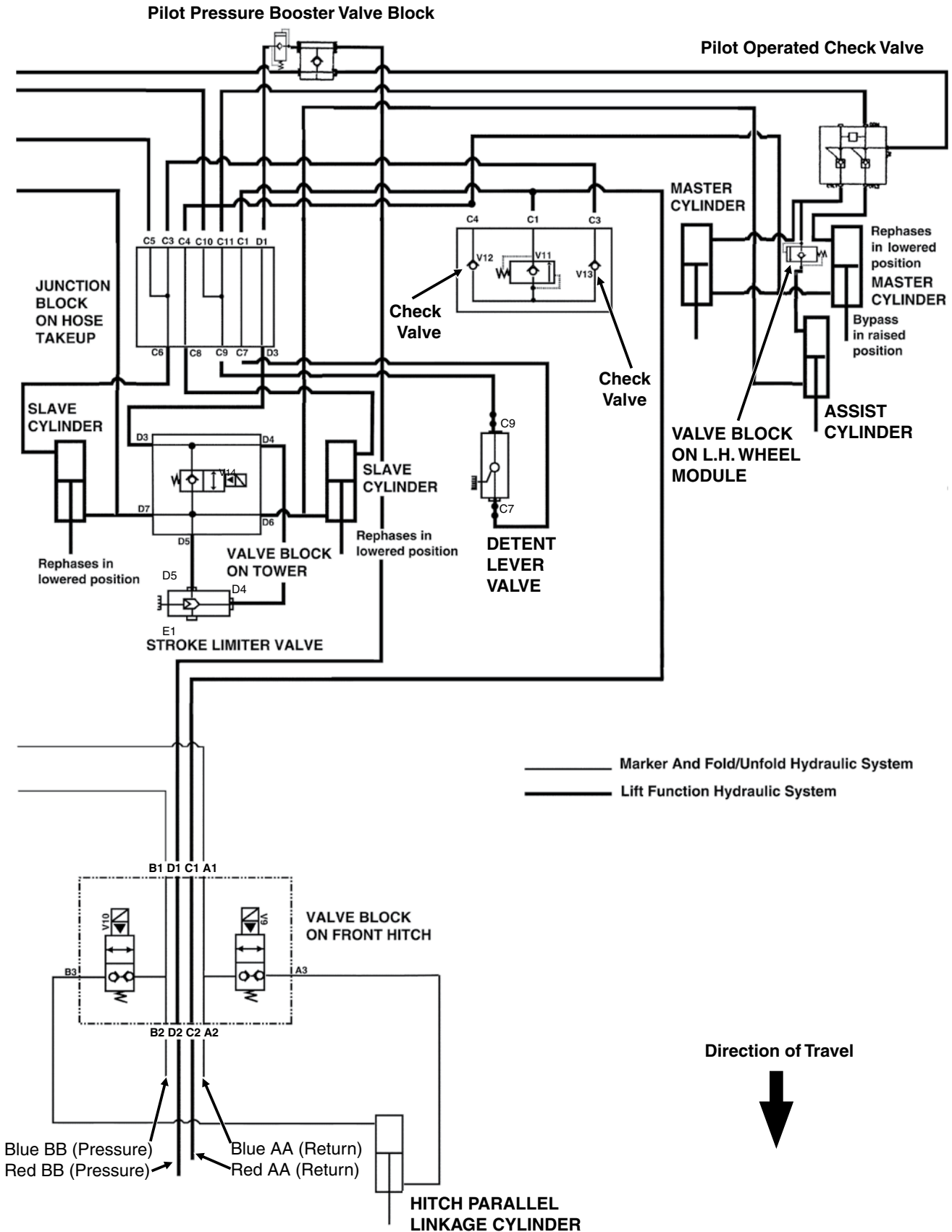

HYDRAULIC VALVE BLOCK LOCATIONS

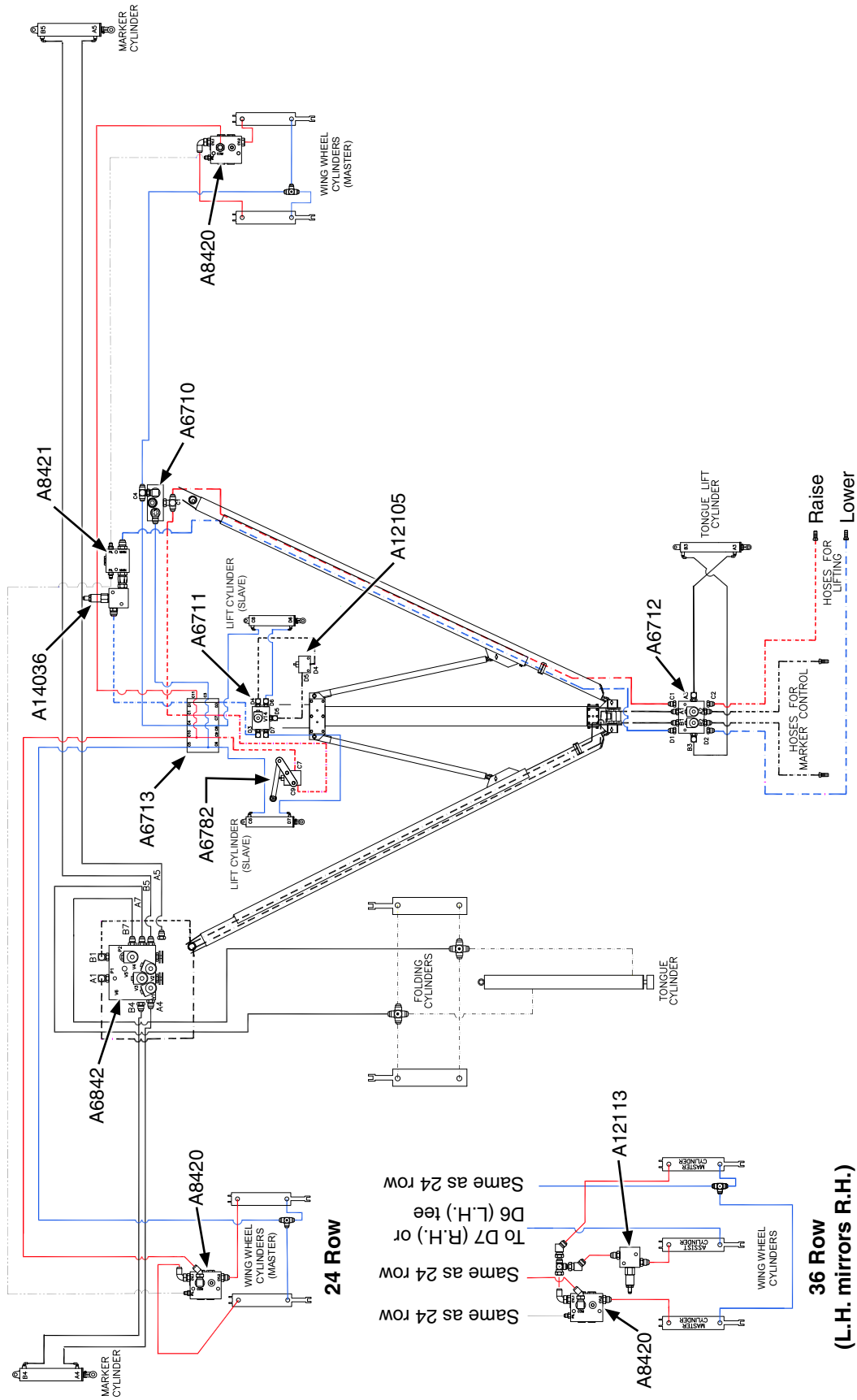

## HYDRAULIC VALVE BLOCK FUNCTIONS

### **A6710 Valve Block On L.H. Wing**

1500 psi relief valve. Allows lower from transport.

### **A6711 Valve Block On Tower**

Oil enters D3 and flows past V14 to rod end of slave cylinders when lowering planter.

Oil from rod side of slave cylinders goes in D6 and D7 when raising planter. V14 is closed so oil goes out D5 to height stop plunger and comes back in on D4 to tractor.

Oil flows directly to tractor when V14 is energized and allows planter to raise to transport height.

### **A6712 Valve Block On Front Hitch**

Controls tongue lift cylinder and routes hydraulic hoses to left and right side drag links.

### **A6713 Junction Block On Hose Take-Up**

Planter lift circuit junction block. Routes hydraulic flow to all planter lift related valves.

### **A6782 Detent Lever Valve**

Blocks oil from exiting wing cylinders when lowering until center of planter reaches a predetermined height (level toolbars) and then is mechanically opened.

### **A6842 Valve Block on R.H. Wing**

Controls markers and marker speed. Routes hydraulic flow to tongue and fold cylinders.

### **A8420 Pilot Operated Check Valve**

Traps oil in butt ends of wing cylinders until pilot pressure from A8421 opens check valves and allows cylinders to retract.

If L.H. side raises slowly or is erratic, check P2 to ensure O-ring and backups are removed.

### **A8421**

Opens pilot operated check valves in A8420 when lowering.

### **A12105 Stroke Limiter Valve**

Shuts off hydraulic flow to limit field turn height.

### **A12113 (36 row 20 only) Valve Block on L.H. and R.H. Wheel Module**

Blocks flow from port 2 to 1 until pressure exceeds valve set pressure (1000 psi). Allows free reverse flow from 1 to 2 if pressure at 1 is at least 10 psi greater than pressure at 2.

### **A14036 Pilot Pressure Booster Valve Block**

Located on inboard side of A8421 to create 1000 psi pressure on pilot lines to make wing wheels lower together.

**AIR CLUTCH AIRLINE SCHEMATIC**

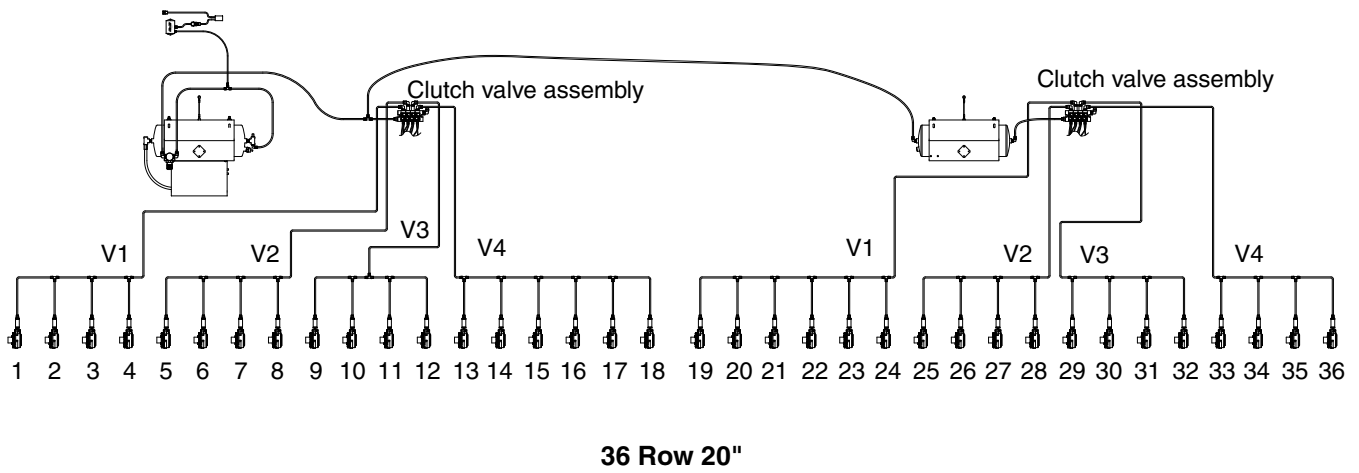
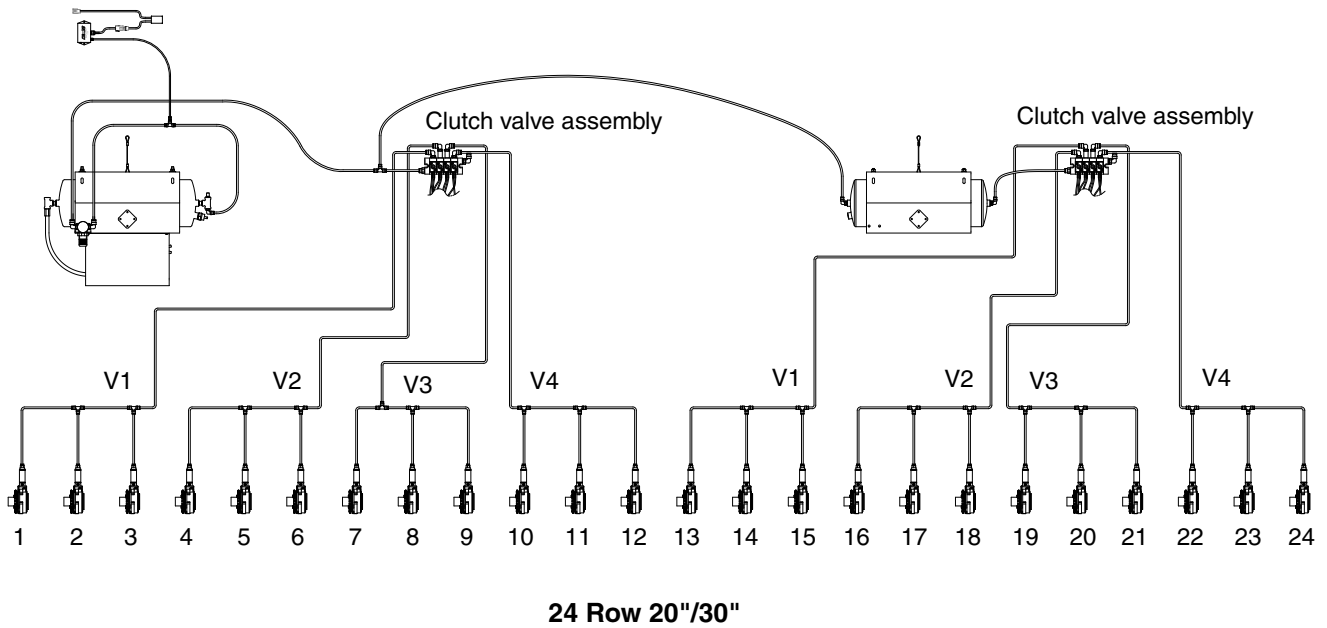

**This page left blank intentionally.**

**KPM III ELECTRONIC SEED MONITOR**

<b>PROBLEM</b>	<b>POSSIBLE CAUSE</b>	<b>SOLUTION</b>
Single sensor communication alarm comes on.	Faulty seed tube sensor.	Replace sensor.
	Break in the harness just before the seed tube sensor.	Inspect for break in harness and repair. If break can't be found, replace harness section.
	Dirty or corroded connector.	Clean connector.
Sensor communication alarms come on for all sensors.	Faulty monitor.	Repair/Replace monitor.
	Break in the harness just after the monitor.	Inspect for break in harness and repair. If break can't be found, replace harness section.
	Dirty or corroded connector.	Clean connector.
Sensor communication alarms come on for some sensors.	Break in the harness.	Inspect for break in harness and repair. If break can't be found, replace harness section corresponding with alarming sensors.
	Dirty or corroded connector.	Clean connector.
Faulty monitor values (such as speed, area, etc.) being displayed.	Incorrect monitor settings.	Change settings to properly correspond to the system.
	Faulty radar/magnetic distance sensor.	Replace sensor.
	Improperly mounted radar sensor.	Properly mount sensor.
Underplanting or no planting alarm on a single sensor when planting (alarm on with a single bargraph segment on and a flashing row number on a single row.	Seed tube sensor is blocked.	Clean sensor.
	Faulty seed tube sensor.	Replace sensor.
	Meter not planting or underplanting.	Repair/replace meter.
	Chain broken or off sprocket.	Repair as necessary.
Seed tube sensor dirty or blocked warning comes on.	Seed tube sensor is dirty.	Clean sensor.
	Faulty seed tube sensor.	Replace sensor.
LED on seed tube sensor will not come on.	Faulty seed tube sensor.	Replace sensor.
	Dirty or corroded connector.	Clean connector.
	Break in the harness just before the sensor.	Repair harness.
Erroneous MPH readings at idle. (Radar Distance Sensor Only)	Radar sensor not located in a stable location.	Relocate to a more stable location.

**LIFT CIRCUIT**

<b>PROBLEM</b>	<b>POSSIBLE CAUSE</b>	<b>SOLUTION</b>
Field turn around toolbar height is not 39"-41".	Stroke limiter valve is out of adjustment.	Consult your Kinze Dealer for service.
Planter not leveling out when lowering from transport.	Detent lever valve out of adjustment.	Consult your Kinze Dealer for service.
Planter settles.	Lift cylinder leaking.	Repair or replace cylinder.

**PISTON PUMP**

<b>PROBLEM</b>	<b>POSSIBLE CAUSE</b>	<b>SOLUTION</b>
Pump hard or impossible to prime.	Valves fouled or in wrong place.	Inspect and clean valves.
	Air leak in suction line.	Repair leak.
	Pump set too low.	Adjust pump setting.
	Packing washers worn out.	Replace.
Low metering.	Valves fouled or in wrong place.	Inspect and clean valves.
	Air leak in suction line.	Repair leak.
	Pump set too low.	Adjust pump setting.
	Broken valve spring.	Replace spring.
Over meters.	Broken discharge valve spring.	Replace spring.
	Trash under valves.	Inspect and clean valves.
	Improper rate setting.	Adjust pump setting.
Leaks through when stopped.	Broken discharge valve spring.	Replace spring.
	Trash under valves.	Inspect and clean valves.
Fertilizer solution leaking under stuffing box.	Packing washers worn out.	Replace.
Pump using excessive oil.	Oil seals or O-ring worn and leaking.	Replace.
Pump operates noisily.	Crankcase components worn excessively.	Inspect and replace if necessary.

## POINT ROW CLUTCH

PROBLEM	POSSIBLE CAUSE	SOLUTION
No clutches disengage.	Main fuse blown in control console.	Replace defective fuse.
	Poor terminal connection in wiring harness.	Repair or replace.
	Wiring damage in wiring harness.	Repair or replace.
	Low voltage at coil. (12 volts required)	Check battery connections.
One section of planter will not re-engage.	Shear pin at seed drive transmission(s) sheared.	Replace pin with one of equal size and grade.
One clutch will not engage.	Fuses blown.	Replace defective fuses.
	Actuator arm and plunger stuck in disengaged position.	Remove, free up, and reinstall.
	Actuator arm out of adjustment.	Adjust actuator arm mounting pin in slot so that actuator arm clears stop on stop collar by approximately " when clutch is rotated.
	Wrap spring broken or stretched.	Disassemble clutch and replace spring.
	Something touching the stop collar.	Check to ensure collar is free to turn with clutch.
	Clutch assembled incorrectly.	Check clutch and diagram for correct assembly.
Clutch slipping.	Wrap spring stretched.	"Lock" clutch output shaft from turning. Place torque wrench on input shaft and rotate in direction of drive. After input shaft has rotated a short distance the wrap spring should tighten onto the input hub. If slippage occurs at less than 100 ft. lbs. replace spring. If spring still slips after installing new spring, replace input hub.
Planter section does not re-engage while planter is moving forward.	Spring in actuator arm not strong enough to push arm operational switch is turned to the ON position.	Remove spring from inside solenoid and stretch spring slightly or replace. Reinstall spring. If that fails, file the away from stop collar when stop on the stop collar slightly so that the stop is not as aggressive.
Frequent solenoid burnout.	Fuses too large.	Replace fuses on front panel with 10 amp slow blow fuses.
Frequent fuse burnout.	Low voltage (12 volts required).	Check power source voltage for partially discharged battery, etc.
	Damage to wiring harness.	Repair or replace harness.
Clutch or clutches will not disengage.	Input and output shafts out of alignment.	Align input and output shafts to prevent drag.
	Input or output shaft is pushed in too far creating a coupler.	Reposition input and output shafts.

**PTO PUMP DRIVE AND OIL COOLER OPTION**

<b>PROBLEM</b>	<b>POSSIBLE CAUSE</b>	<b>SOLUTION</b>
Pump is squealing.	Lack of oil to pump.	Check for plugged suction strainer. Check oil level.
Oil temperature high.	Low oil level.	Check oil level and add as required.
Desired fan speed cannot be achieved.	Low oil level.	Check oil level and add as required.
	Plugged filter.	Check and change as required.
Vacuum level not displayed.	Digital vacuum gauge console power OFF.	Turn ON.
	Cable not plugged in.	Check connection.
	Digital vacuum gauge console has no power.	Check fuse.

### ROW MARKER OPERATION

PROBLEM	POSSIBLE CAUSE	SOLUTION
Right marker lowering slower than left marker.	Solenoid valve cartridge in port V1 not opening completely.	Switch with cartridge in port V2. If problem repeats, replace cartridge.
	Hose pinched or collapsed.	Inspect hose routing. Replace or repair hoses as required.
Left marker lowering slower than right marker.	Solenoid valve cartridge in port V2 not opening completely.	Switch with cartridge in port V1. If problem repeats, replace cartridge.
	Hose pinched or collapsed.	Inspect hose routing. Replace or repair hoses as required.
Both markers lowering.	Solenoid valve cartridge stuck open. If left marker switch is selected, right cartridge (V1) is defective. If right marker switch is selected, left cartridge (V2) is defective.	Replace solenoid valve cartridge.
Neither marker lowers.	Blown fuse.	Check red light on control console. It should be on if switch is on. If light is not on, switch to opposite marker position. If light comes on, switch may be defective. Replace switch. Otherwise replace fuse.
	Coils at V1 and V2 not energized.	Poor ground on wire, bad wire connection or damaged wire. Repair as required.
	Marker flow control valve closed too far.	See "Row Marker Speed Adjustment".
Neither marker will raise.	Marker flow control valve closed too far.	See "Row Marker Speed Adjustment".
Right marker will not lower.	Solenoid coil in port V1 not energized.	Check switch on control console. Replace if defective. Check coil ground wire. Check for poor connection or damaged wire.
	Solenoid cartridge in port V1 stuck closed.	Switch cartridge with one on the planter you know is operating properly. If right marker lowers, replace defective cartridge.
Left marker will not lower.	Solenoid coil in port V2 not energized.	Check switch on control console. Replace if defective. Check coil ground wire. Check for poor connection or damaged wire.
	Solenoid cartridge in port V2 stuck closed.	Switch cartridge with one on the planter you know is operating properly. If left marker lowers, replace defective cartridge.
Markers traveling too fast and damaging rubber stop on transport stands and/or damaging pivot at rod end of marker cylinders.	Marker transport stand not adjusted correctly to allow marker cushion cylinders to operate as designed.	See "Row Marker Transport Stand Adjustment".
	Adjust row marker flow control valve.	See "Row Marker Speed Adjustment".

**SOLENOID VALVE**

<b>PROBLEM</b>	<b>POSSIBLE CAUSE</b>	<b>SOLUTION</b>
No solenoids operate.	Low voltage.	Must be connected to 12 volt DC only. Negative ground.
	Blown fuse.	Replace control console fuse with AGC-15 amp.
	Battery connection.	Clean and tighten.
	Wiring harness damaged.	Repair or replace.
One solenoid valve will not operate.	Bad switch.	Replace on control panel.
	Cut wire in harness.	Locate and repair.
	Bad coil.	Replace.
	Poor connection at coil.	Check.
Valve operating when not energized.	Valve stem stuck open.	Replace cartridge.
	O-ring leaking.	Install new O-ring kit.
	Foreign material under poppet.	Remove and clean cartridge.

**STROKE LIMITER VALVE**

<b>PROBLEM</b>	<b>POSSIBLE CAUSE</b>	<b>SOLUTION</b>
Planter will not raise.	Poppet not moving freely in adapter and mechanical stop has poppet pushed completely in with no air gap.	Remove adapter from valve block. Check movement of poppet in adapter. It should move freely. If not, remove poppet from adapter and clean seal area. Inspect poppet stem for damage.
Planter will not stop at the raised field position.	Mechanical stop arm not adjusted correctly.	Adjust mechanical stop arm.
External leak.	Worn or damaged O-rings.	Install seal kit.

**This page intentionally left blank.**

# MODEL 3700 FRONT FOLDING PLANTER PARTS MANUAL

**M0233-02**

**Rev. 9/11**

This manual applies to:            Model: 3700 and 3700 ASD Front Folding Planters  
2010 Production and on

Record the model number and serial number of your planter along with date purchased:

Serial Number \_\_\_\_\_

Date Purchased \_\_\_\_\_

Information in this manual was current at time of printing. However, due to Kinze's ongoing product improvement, production changes may cause your machine to appear slightly different in detail. Kinze Manufacturing, Inc. reserves the right to change specifications or design without notice and without incurring obligation to install the same on machines previously manufactured.

Right hand (R.H.) and left hand (L.H.), as used throughout this manual, are determined by facing in the direction the machine will travel when in use, unless otherwise stated.

**ROW UNIT**

Shank Assembly, Seed Tube, and Depth Adjustment . . . . P1  
 Pneumatic Down Pressure Package Option . . . . . P3  
 Air Clutch, Pull Row Unit . . . . . P5  
 Parallel Arms, Mounting Support Plate, and Quick Adjustable Down Forces Springs Option. . . . . P7  
 15" Seed Opener Disc Blade/Bearing Assembly and Scrapers . . . . . P9  
 Gauge Wheels . . . . . P11  
 "V" Closing Wheels . . . . . P13  
 Hopper Support and Meter Drive. . . . . P15  
 Seed Hopper and Lid. . . . . P17  
 Finger Pickup Seed Meter . . . . . P19  
 Brush-Type Seed Meter. . . . . P21  
 EdgeVac Seed Meter. . . . . P23  
 Granular Chemical Hopper and Hopper Panel Extension . . . . . P25  
 Granular Chemical Meter and Meter Drive . . . . . P27  
 Granular Chemical Banding Options . . . . . P29  
 Spring Tooth Incorporator . . . . . P31  
 Row Unit Mounted No Till Coulter . . . . . P32  
 Row Unit Mounted Disc Furrower . . . . . P33  
 Row Unit Mounted Residue Wheel . . . . . P35  
 Coulter Mounted Residue Wheels . . . . . P37  
 Frame Mounted Coulter W/Residue Wheels . . . . . P39

**EDGEVAC SYSTEM**

Vacuum System. . . . . P41  
 Vacuum Fan Hydraulic Components . . . . . P43  
 Vacuum Fan Reservoir Assembly . . . . . P44  
 Reservoir Hose Supports/Clamps on Hitch . . . . . P45  
 Vacuum Fan Hydraulic Motor Assembly . . . . . P46  
 Vacuum Fan Motor Valve Block Assembly . . . . . P47  
 Manifolds and Distribution Hoses, 24 Row 30" . . . . . P49  
 Manifolds and Distribution Hoses, 36 Row 20" . . . . . P51  
 Vacuum Fan/Manifold Mounting Supports and Hardware . . . . . P53  
 PTO Pump Assembly. . . . . P55

**AIR SEED DELIVERY SYSTEM (ASD)**

ASD Fan System . . . . . P57  
 ASD Hydraulic Schematic . . . . . P59  
 ASD Hoses, 24 Row 30" . . . . . P61  
 ASD Hoses, 36 Row 20" . . . . . P63  
 ASD Manifolds and Distribution Hoses . . . . . P65  
 ASD Entrainer Assembly, 24 Row 30" . . . . . P67  
 ASD Entrainer Assembly, 36 Row 20" . . . . . P69  
 ASD Tank Assembly. . . . . P71

ASD Scale Package. . . . . P73  
 ASD Mechanical Row Unit. . . . . P75  
 ASD Catwalk, 24 Row 30" . . . . . P77  
 ASD Catwalk, 36 Row 20" . . . . . P79  
 ASD Stair, 24 Row 30" . . . . . P81

**BASE MACHINE**

Front Hitch Assembly/Safety Chain . . . . . P83  
 Hitch and Linkage Assembly, 24 Row 20" . . . . . P86  
 Hitch and Linkage Assembly, 24 Row 30" and 36 Row 20" . . . . . P87  
 Front Hitch Assembly (Rear Section). . . . . P89  
 Front Wear Pads . . . . . P90  
 Tower Assembly, 24 Row 20" . . . . . P92  
 Tower Assembly, 24 Row 30" and 36 Row 20" . . . . . P93  
 Stroke Limiter/Detent Valve Assembly and Linkage. . . . . P95  
 Hinge and Wing Assemblies . . . . . P97  
 Hinge and Wing Assemblies . . . . . P98  
 Wing Frame, 24 Row 30" . . . . . P99  
 Wing Frame, 36 Row 20" . . . . . P101  
 Hose Take-Up . . . . . P103  
 Axle and Transport Lockup . . . . . P105  
 Transport Wheel and Hub Assembly . . . . . P106  
 Wheel Module Assembly . . . . . P107  
 Ground Drive Tire Assembly . . . . . P110  
 Contact Wheel Assembly. . . . . P111  
 Point Row Clutch . . . . . P113  
 Two-Speed Point Row Clutch. . . . . P115  
 Two-Speed Point Row Clutch Wheel Module Extensions. . . . . P117  
 Airline Fittings and Hoses, 24 Row 30" . . . . . P119  
 Airline Fittings and Hoses, 36 Row 20" . . . . . P120  
 Air Compressor and Dual Solenoid Assembly. . . . . P123  
 Accumulator Assembly . . . . . P125  
 Seed Rate Transmission and Driveline . . . . . P127  
 Ratchet/Sprocket Assembly. . . . . P129  
 Row Marker Assembly. . . . . P130  
 Row Marker Spindle/Hub/Blade. . . . . P133

**HYDRAULICS**

Slave Cylinders . . . . . P135  
 Master Cylinder . . . . . P135  
 Hitch Paralled Linkage Cylinder. . . . . P136  
 Assist Cylinder, 36 Row 20" . . . . . P137  
 Row Marker (Cushion) Cylinder. . . . . P138  
 Helper Cylinder, All Sizes. . . . . P139  
 Tongue Cylinder, 24 Row 20" . . . . . P140

Tongue Cylinder, 24 Row 30" and 36 Row 20" . . . . .	P141
Valve Block on Front Hitch . . . . .	P143
Valve Block on Tower Assembly . . . . .	P144
Valve Block on R.H. Wing . . . . .	P145
Valve Block on L.H. Wing . . . . .	P147
Pilot Pressure Booster Valve Block . . . . .	P148
Valve Block on L.H. and R.H. Wheel Module . . . . .	P148
Junction Block on Hose Take-Up . . . . .	P149
Detent Lever Valve . . . . .	P150
Junction Block - Located on L.H. Wing . . . . .	P150
Stroke Limiter Valve . . . . .	P151
Pilot Operated Check Valve . . . . .	P151
Solenoid Valve (G1K276) . . . . .	P152
Solenoid Valve (G1K275) . . . . .	P152
Pressure Relief Valves . . . . .	P153
Check Valve . . . . .	P153
Flow Control Valve . . . . .	P153
Clutch Valve Assembly . . . . .	P154
ASD Valve Block . . . . .	P155
Hydraulic System, 24 Row 20" . . . . .	P157
Hydraulic System, 24 Row 30" . . . . .	P159
Hydraulic System, 36 Row 20" . . . . .	P161

## ELECTRONICS

Electrical Components . . . . .	P163
Light/Reflective Decal Brackets and Extensions . . . . .	P166
KPM III Electronic Seed Monitor . . . . .	P167
Planter Monitor Module (PMM) . . . . .	P171
Kinze Cobalt Display . . . . .	P173
Kinze Vision Display . . . . .	P175
Integra Display . . . . .	P177

## FERTILIZER

Liquid Fertilizer Piston Pump Drive . . . . .	P179
Liquid Fertilizer Piston Pump Mount and Ground Drive Wheel . . . . .	P181
Liquid Fertilizer Hoses and Fittings . . . . .	P183
Liquid Fertilizer Piston Pump, NGP-6055 . . . . .	P185
Liquid Fertilizer Piston Pump, NGP-7055 . . . . .	P187
Liquid Fertilizer Piston Pump Flow Divider . . . . .	P189
Rear Trailer Hitch . . . . .	P191

<b>DECALS, PAINT, AND MISCELLANEOUS . . . . .</b>	<b>P193</b>
<b>NUMERICAL INDEX . . . . .</b>	<b>P206</b>

(A11692/A11156/GR1736/A10765/A11158/A11699/A7856/A11155/A8329/A11757)

**Vacuum Fan Assembly**

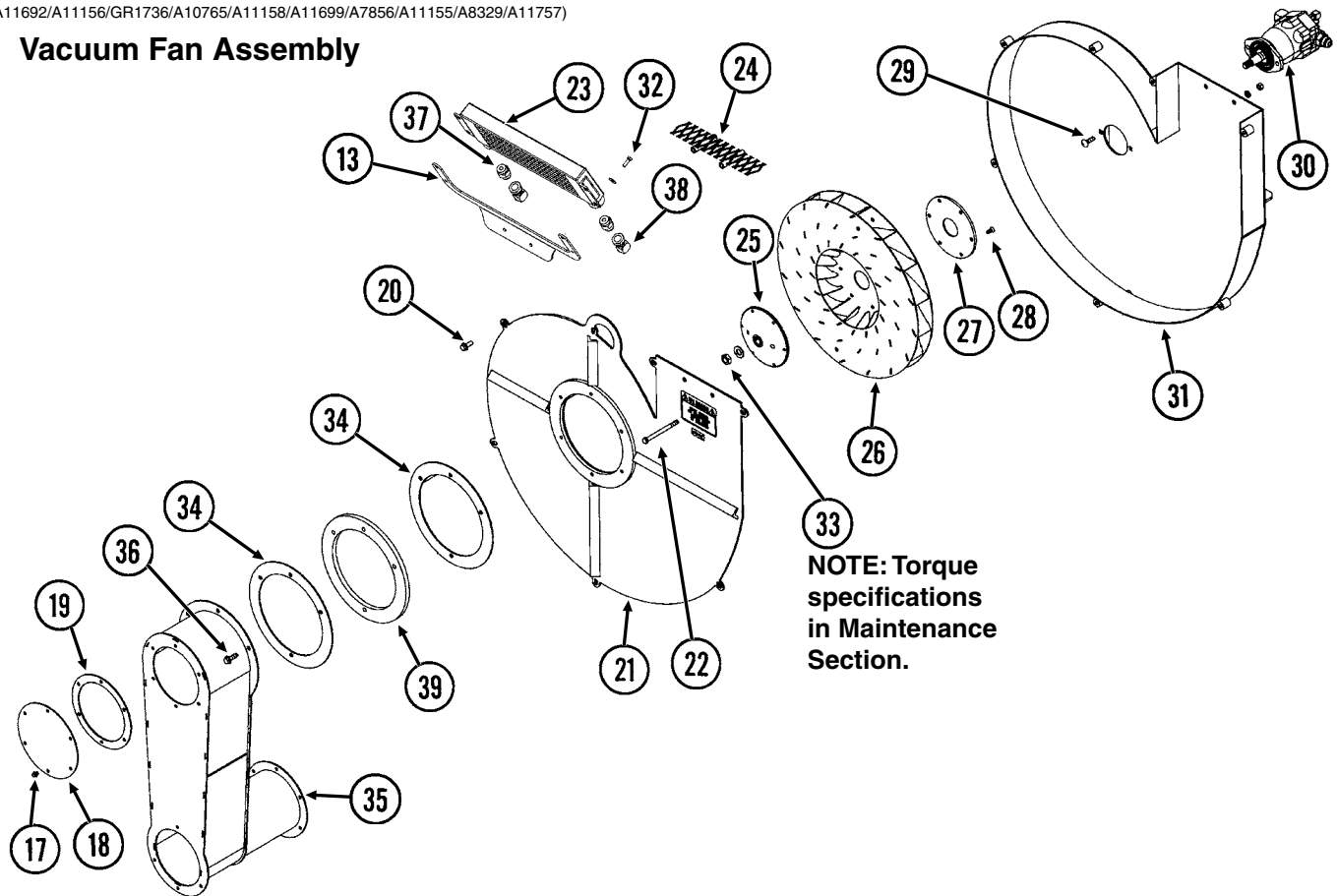

ITEM	PART NO.	QTY.	DESCRIPTION
1	G8081X	1	Backlite Control Console Assembly W/Mounting Brackets, Harness W/Dust Cap And Power Cable
	GD14640	-	Mounting Bracket
	GA6975	-	Knob
	GD2829	-	Fuse, 15 Amp, Type AGC
2	GA11156	1	Sending Unit W/¼" Tubing And Harness
	GD16324-01	-	Tubing, ¼" x 45"
	GA9964	-	Strain Relief
3	GR1736	1	Hose Barb, ⅛" Male NPT To Barb
4	GD15849-02	1	Clear Tube, ⅝" O.D. x ⅜" I.D. x 120"
5	GA10765	1	Analog Vacuum Gauge W/Hose Barb
	GR1777	-	Hose Barb, ⅛" Male NPT To 3/16" Barb
6	GA10799	1	Breather, ⅛" Male NPT
7	G10001	1	Hex Head Cap Screw, ⅜"-16 x 1"
	G11387	1	Flat Washer, ⅜" SAE
	G10108	1	Lock Nut, ⅜"-16
8	G11215	3	Hex Socket Head Cap Screw, No. 6-32 x ⅜", Grade 8
9	GD15804	1	Mount
10	GD15803	1	Support
11	G1K321	-	2-Pin Female Connector Kit (Black), Includes: (3) 2-Pin Female Housings, (6) Pin Contacts, (6) Seals
12	G1K320	-	2-Pin Male Connector Kit (Black), Includes: (3) 2-Pin Male Housings, (6) Socket Contacts, (6) Seals
13	GD16608	1	Bracket
14	GA11691	-	Harness, 519", 24 Row 30" And 36 Row 20"
15	GA8328	-	4-Pin Female Connector Kit, Includes: (1) 4-Pin Female Housing, (4) Seals, (4) Pin Contacts
16	GA8329	-	4-Pin Male Connector Kit, Includes: (1) 4-Pin Male Housing, (4) Seals, (4) Sockets

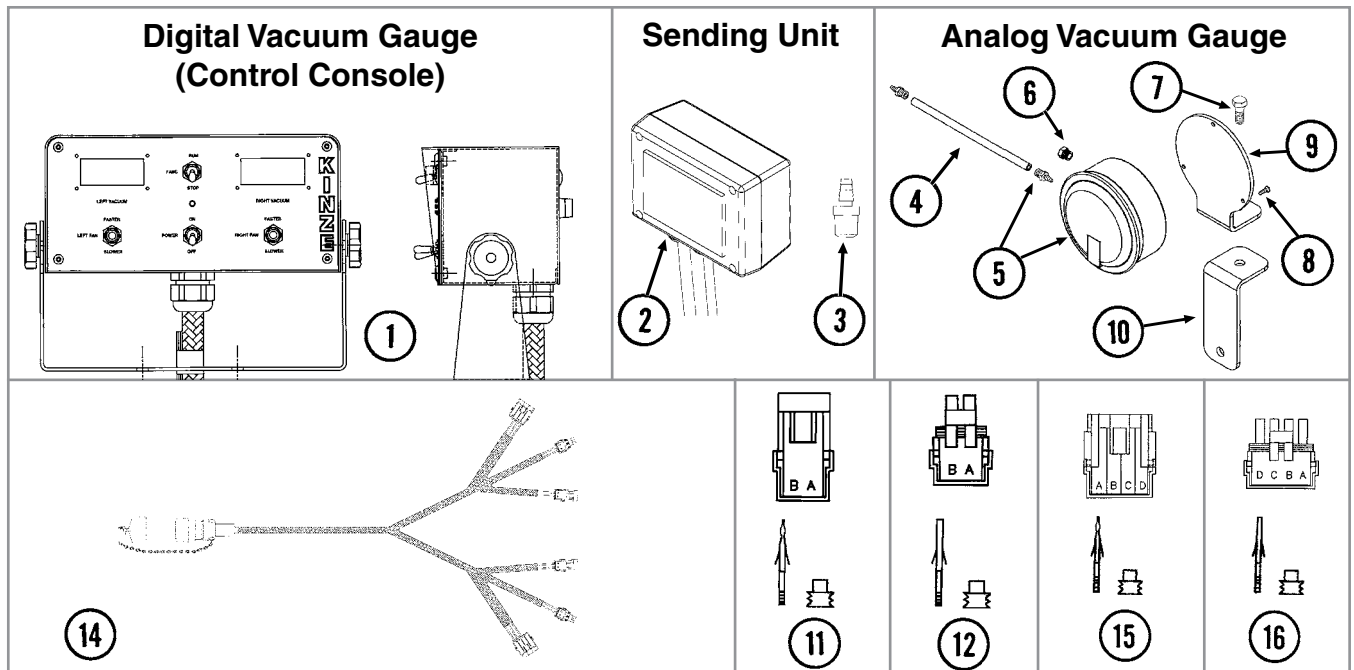

ITEM	PART NO.	QTY.	DESCRIPTION
17	G11166	6	Whiz Lock Bolt, 1/4"-20 x 3/4"
18	GD16840	1	Cover
19	GD16991	1	Cover Gasket, 1/8" x 8 3/8" (6 1/2" I.D.)
20	G11124	7	Whiz Lock Bolt, 3/8"-18 x 1"
21	GA10752	1	Cover
22	G10063	2	Hex Head Cap Screw, 3/8"-16 x 4"
	G11387	2	Flat Washer, 3/8" SAE
	G10108	2	Lock Nut, 3/8"-16
23	GA10917	1	Oil Cooler
24	GA11987	2	Screen
25	GD15790	1	Hub
26	GA10635	1	Impeller
27	GD15789	1	Backing Plate
28	G11133	6	Hex Socket Head Cap Screw, 5/16"-18 x 3/4", Grade 8
29	G10599	2	Carriage Bolt, 3/8"-16 x 1 1/4"
	G10229	2	Lock Washer, 3/8"
	G10101	2	Hex Nut, 3/8"-16
30	---	-	<a href="#">See "Vacuum Fan Hydraulic Motor Assembly" on page P46</a>
31	GA10148	1	Shroud
32	G10019	4	Hex Head Cap Screw, 5/16"-18 x 1"
	G11386	4	Flat Washer, 5/16" SAE
	G10109	4	Lock Nut, 5/16"-18, Grade B
33	G11391	1	Flat Washer, 3/8" SAE
	G10499	1	Hex Jam Nut, 5/8"-18, Grade 2
34	GD16992	2	Gasket, 1/8" x 11 7/8"
35	GA11651	1	Outlet, 31 11/16"
	GA12457	-	Outlet, 35 11/16"
36	GD19246-01	4	Stud, 3/8"-16
	G10901	4	Lock Nut, 3/8"-16
	G11387	4	Flat Washer, 3/8" SAE
37	G6400-12	2	Connector W/O-Ring, 1 1/16"-12 Male JIC To O-Ring
	GR1467	-	O-Ring
38	G6502-12	1-2	Swivel Elbow, 45°, 1 1/16"-12 Male JIC To Female
39	GD16839	1	Spacer, 1/2" x 12"
A	GA11757	-	Vacuum Fan Assembly (Items 13, 20-22, 24-31, and 33)

(IP1169)

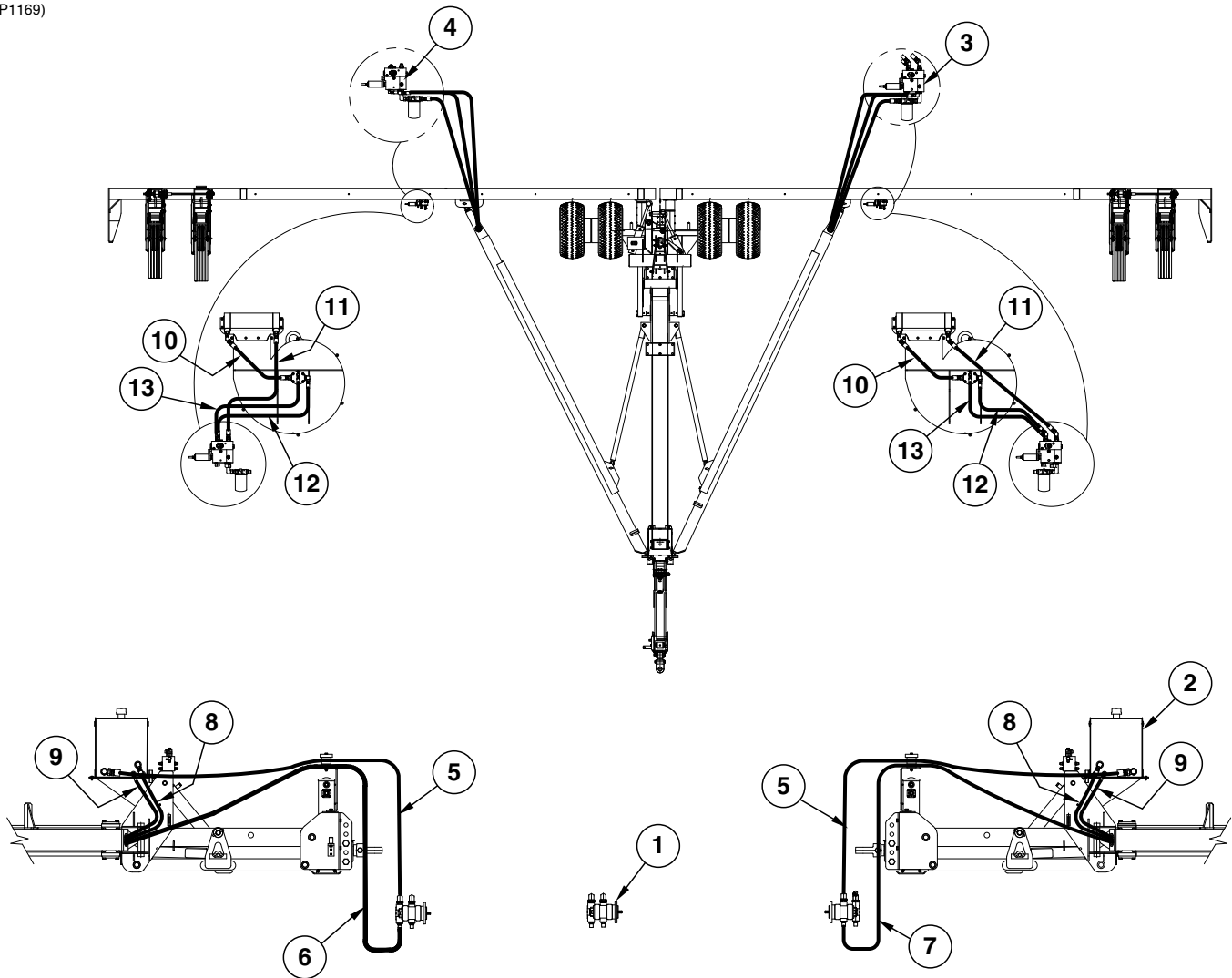

ITEM	PART NO.	QTY.	DESCRIPTION
1	---	-	<a href="#">See "PTO Pump Assembly" on page P55</a>
2	---	-	<a href="#">See "Vacuum Fan Reservoir Assembly" on page P44</a>
3	---	-	<a href="#">See "Vacuum Fan Motor Valve Block Assembly" on page P47</a>
4	---	-	<a href="#">See "Vacuum Fan Motor Valve Block Assembly" on page P47</a>
5	*A11800	2	Hose Assembly, 1¼" x 123"
6	*A11433	-	Hose Assembly, 5⁄8" x 424"
7	*A11432	-	Hose Assembly, 5⁄8" x 412"
8	*A12904	-	Hose Assembly, 3⁄4" x 330"
9	*A12052	-	Hose Assembly, 3⁄8" x 340"
10	*A3381	2	Hose Assembly, 3⁄4" x 26"
11	*A3292	1	Hose Assembly, 3⁄8" x 22"
12	*A11431	2	Hose Assembly, 5⁄8" x 34"
13	*A12051	2	Hose Assembly, 3⁄8" x 36"

\* Hydraulic hose is not stocked by Kinze Repair Parts, but can be made available on a special order basis. Call for quote.

(FF105a)

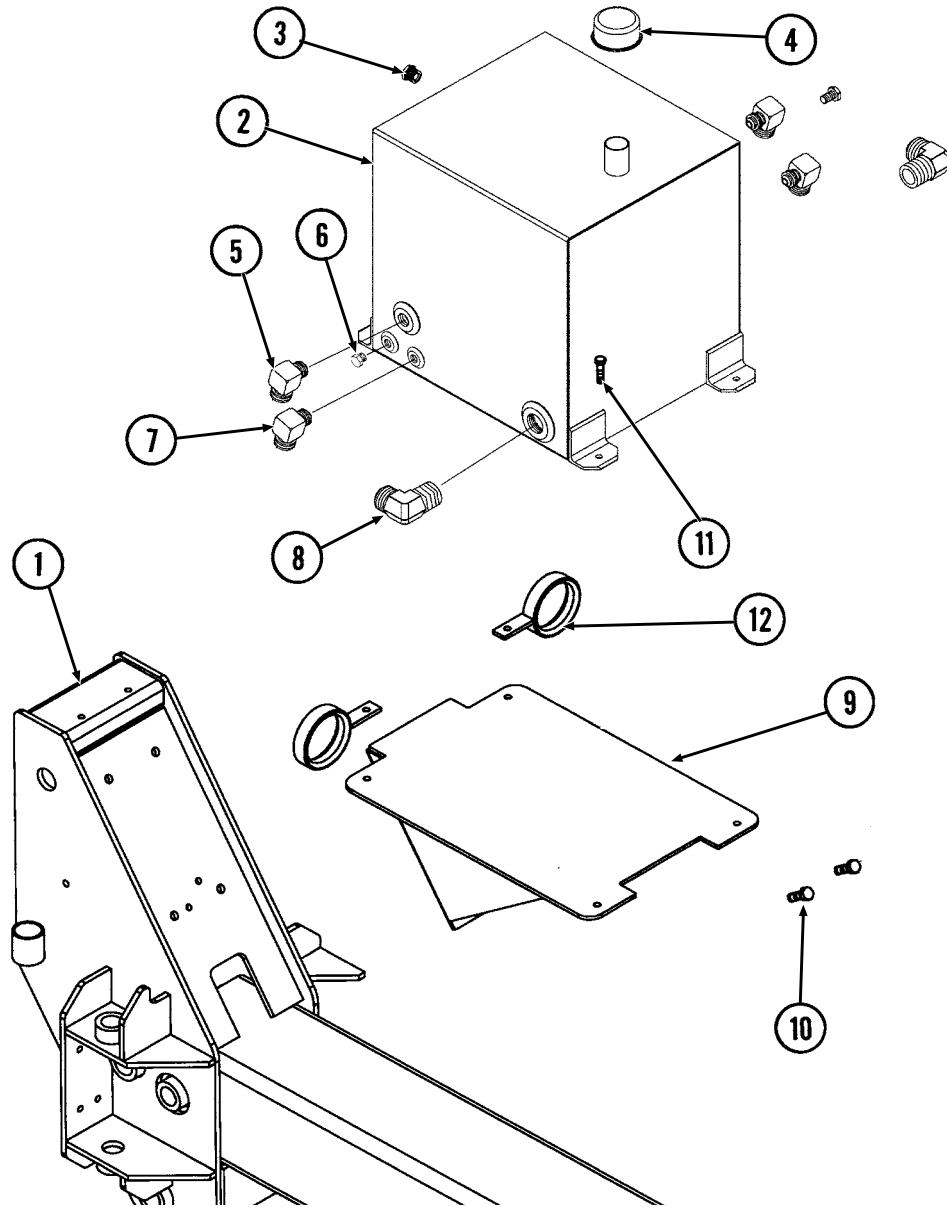

ITEM	PART NO.	QTY.	DESCRIPTION
1	---	-	<a href="#">See "Front Hitch Assembly (Rear Section)" on page P89</a>
2	GA13696	1	Reservoir
3	GD17091	1	Liquid Level Sight
4	GR1834	1	Breather
5	G2501-12-16	2	Elbow, 90°, 1 1/16"-12 Male JIC To 1" NPT
6	G5406-08	2	Plug, 3/4" NPT Hex Head
7	G2501-06-08	2	Elbow, 90°, 9/16"-18 Male JIC To 1/2" NPT
8	G2501-20-16	2	Elbow, 90°, 1 5/8"-12 Male JIC To 1" NPT
9	GA11695	1	Mount
10	G10017	4	Hex Head Cap Screw, 1/2"-13 x 1 1/2"
	G10111	4	Lock Nut, 1/2"-13
11	G10003	6	Hex Head Cap Screw, 3/8"-16 x 1 1/2"
	G10108	6	Lock Nut, 3/8"-16
12	GA11697	2	Hose Guide

(FF105c)

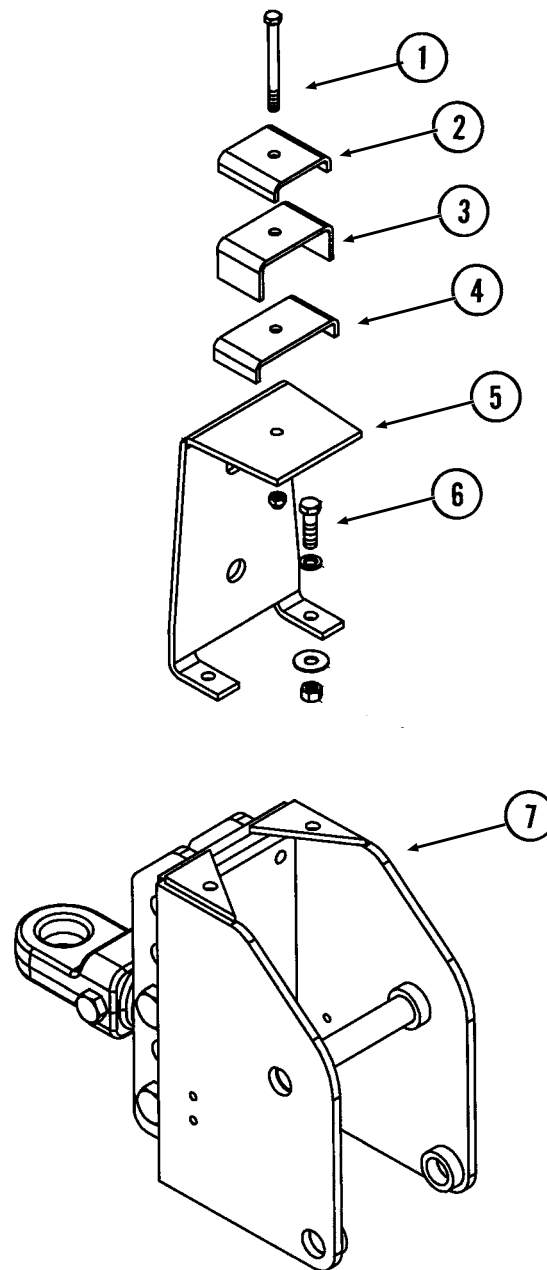

ITEM	PART NO.	QTY.	DESCRIPTION
1	G10980	1	Hex Head Cap Screw, 1/2-13 x 5 1/2"
	G10111	1	Lock Nut, 1/2"-13
2	GD0740	1	Hose Clamp, 3/4" x 4" x 3 1/2"
3	GD17024	1	Hose Clamp, 2" x 3" x 4 3/4"
4	GD8188	1	Hose Clamp, 7/8" x 3" x 5 3/8"
5	GD16922	1	Support
6	G10006	2	Hex Head Cap Screw, 5/8"-11 x 2 1/4"
	G10230	2	Lock Washer, 5/8"
	G11391	2	Flat Washer, 5/8" SAE
	G10104	2	Hex Nut, 5/8"-11
7	---	-	<a href="#">See "Front Hitch Assembly/Safety Chain" on page P83</a>

(METR21b)

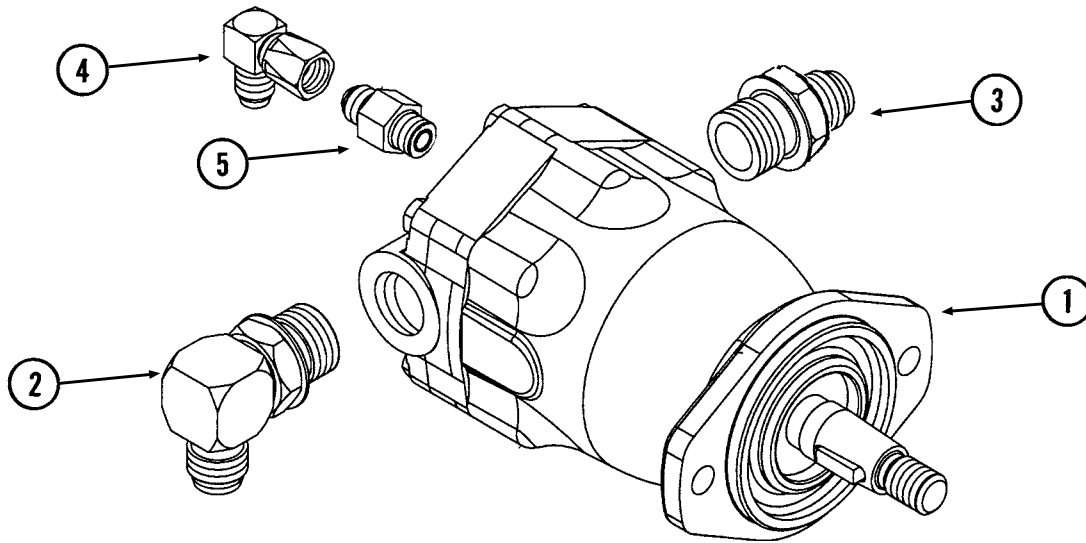

ITEM	PART NO.	QTY.	DESCRIPTION
1	GA10149 GR1734	1 -	Hydraulic Motor Seal Kit
2	G6801-10-12 GR1467	1 -	Elbow W/O-Ring, 90°, 7/8"-14 Male JIC To 1 1/16"-12 O-Ring O-Ring
3	G6400-12 GR1467	2 -	Connector W/O-Ring, 1 1/16"-12 Male JIC To O-Ring O-Ring
4	G6500-06	1	Swivel Elbow, 90°, 9/16"-18 Male JIC To Female
5	G6400-06 GR1045	1 -	Connector W/O-Ring, 9/16"-18 Male JIC To O-Ring O-Ring

(FF107-A11907)

L.H. Side Shown

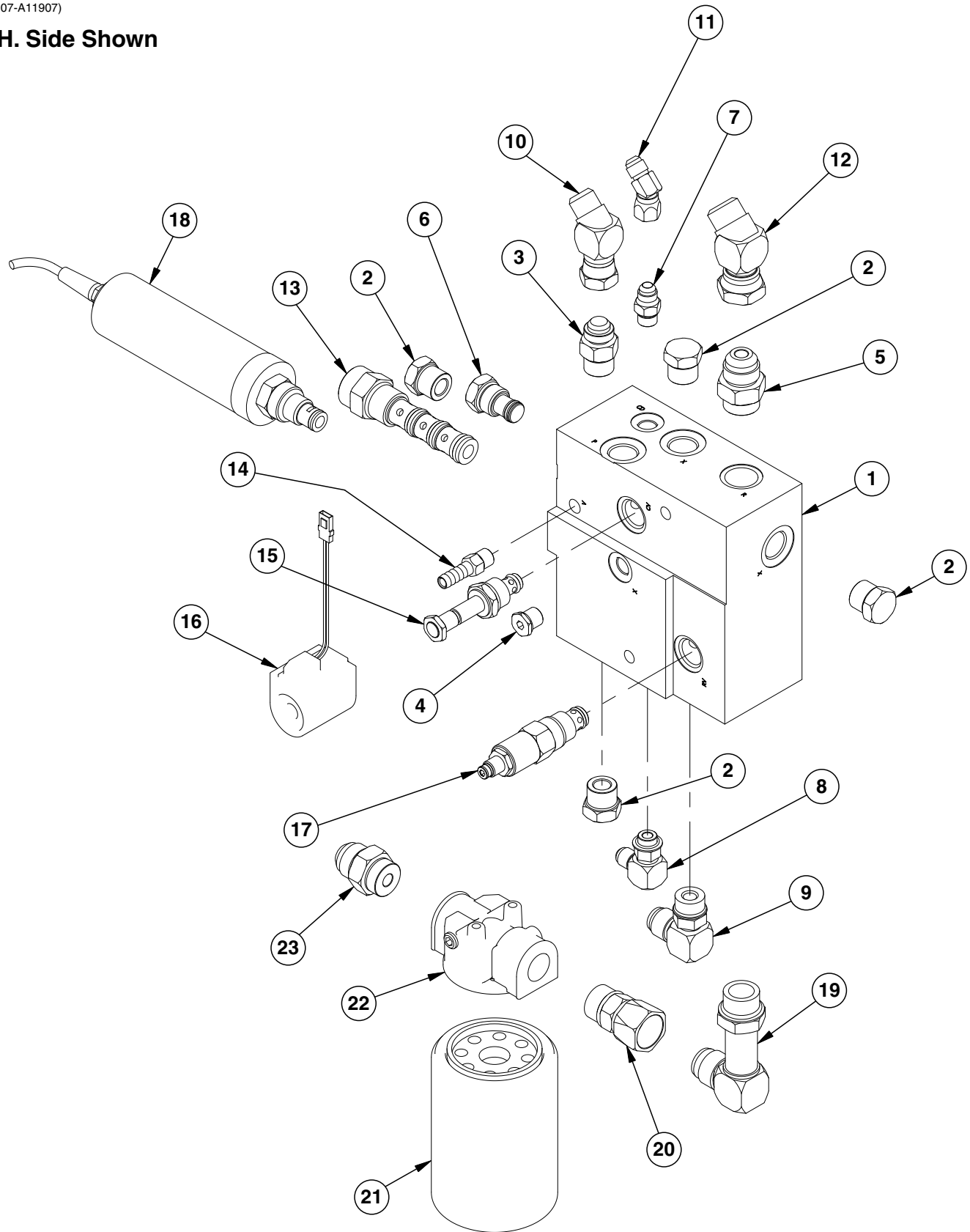

ITEM	PART NO.	QTY.	DESCRIPTION
1	GD16873	1	Valve Block
2	G6408-10 GR1466	4 -	Plug W/O-Ring, 7/8"-14 O-Ring O-Ring
3	G6400-10 GR1466	1 -	Connector W/O-Ring, 7/8"-14 Male JIC To O-Ring O-Ring
4	G6408-H06-0 GR1045	1 -	Hex Socket Head Plug W/O-Ring, 9/16"-18 O-Ring O-Ring
5	G6400-12 GR1467	1 -	Connector W/O-Ring, 1 1/16"-12 Male JIC To O-Ring O-Ring
6	GA11934	1	Relief Valve Cartridge
7	G6400-06 GR1045	1 -	Connector W/O-Ring, 9/16"-18 Male JIC To O-Ring O-Ring
8	G6801-06 GR1045	1 -	Elbow W/O-Ring, 90°, 9/16"-18 Male JIC To O-Ring O-Ring
9	G6801-10 GR1466	1 -	Elbow W/O-Ring, 90°, 7/8"-14 Male JIC To O-Ring O-Ring
10	G6502-10	1	Swivel Elbow, 45°, 7/8"-14 Male JIC To Female (L.H. Side Only)
11	G6502-06	1	Swivel Elbow, 45°, 9/16"-18 Male JIC To Female (L.H. Side Only)
12	G6502-12	1	Swivel Elbow, 45°, 1 1/16"-12 Male JIC To Female (L.H. Side Only)
13	GA11682	1	Pressure Compensating Element
14	GD11700	1	Adapter, 1/4" NPT To 3/8" Barb
15	GA11680	1	Cartridge
16	GA11900	1	Coil W/Terminals
17	GA11679	1	Relief Valve
18	GA10986	1	Motorized Flow Control
19	G6801-LL-12	1	X-Long Elbow W/O-Ring, 90°, 1 1/16"-12 Male JIC x 1 1/16"-12
20	G6402-12-12	1	Connector W/O-Ring, 1 1/16" Female JIC x 1 1/16"-12
21	GD16037	1	Oil Filter, 10 Micron
22	GD16038	1	Filter Head
23	G6400-12 GR1467	1 -	Connector, W/O-Ring, 1 1/16"-12 Male JIC To O-Ring O-Ring

(FF112/IP1161)

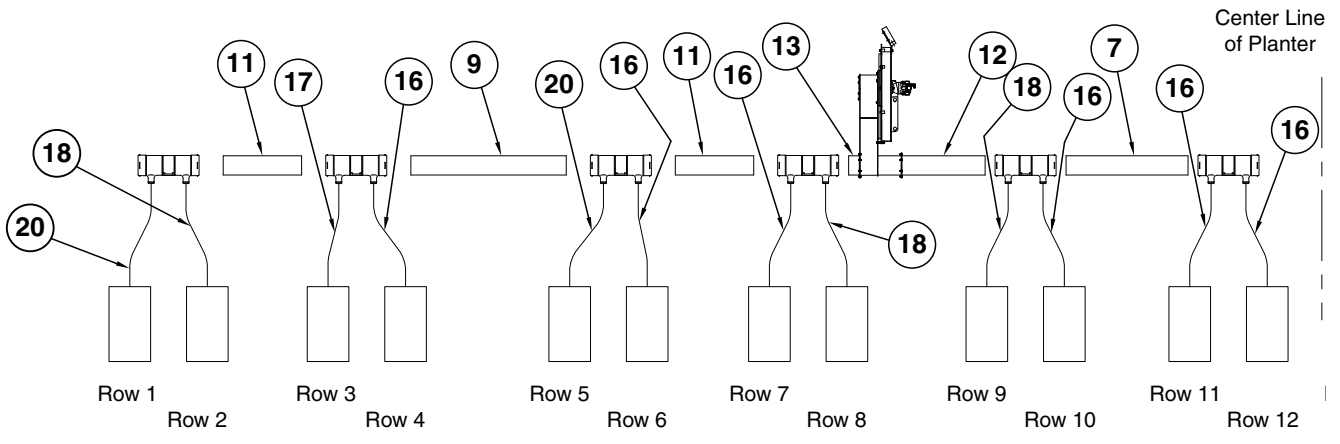
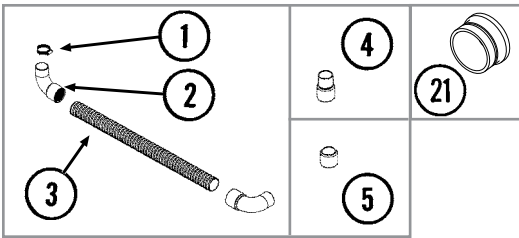

L.H. Side of Planter

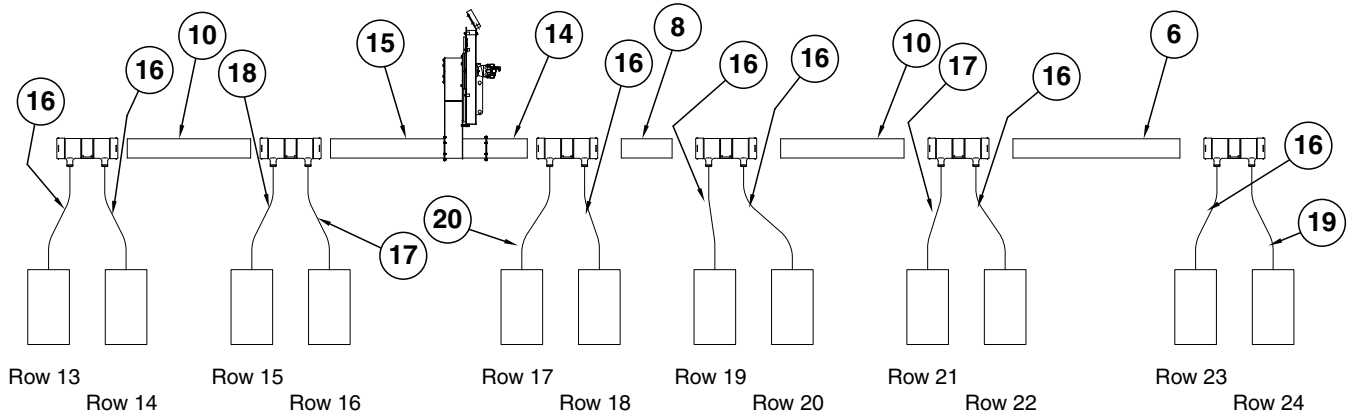

R.H. Side of Planter

ITEM	PART NO.	QTY.	DESCRIPTION
1	G10676	24	Hose Clamp, No. 36, Stainless Steel
2	GD14626	32	Elbow, 90°, 2"
3	---	-	See items 16-19
4	GD14627	16	Coupler, 2"
5	G11147	-	Cap, 2"
6	GD15836-37	1	Pipe, 6" x 57½"
7	GD15836-07	1	Pipe, 6" x 42"
8	GD15836-05	1	Pipe, 6" x 17½"
9	GD15836-18	1	Pipe, 6" x 53½"
10	GD15836-32	2	Pipe, 6" x 42½"
11	GD15836-26	2	Pipe, 6" x 27"
12	GA13194	1	Manifold Flange, 29"
13	GA13195	1	Manifold Flange, 4"
14	GA13192	1	Manifold Flange, 14"
15	GA13193	1	Manifold Flange, 39¼"
16	GD15792-20	13	Hose, 2" x 32"
17	GD15792-23	3	Hose, 2" x 34"
18	GD15792-04	4	Hose, 2" x 36"
19	GD15792-24	1	Hose, 2" x 40"
20	GD15792-14	3	Hose, 2" x 46"
21	GD17052	-	Vacuum Plug

(FF112/IP1162)

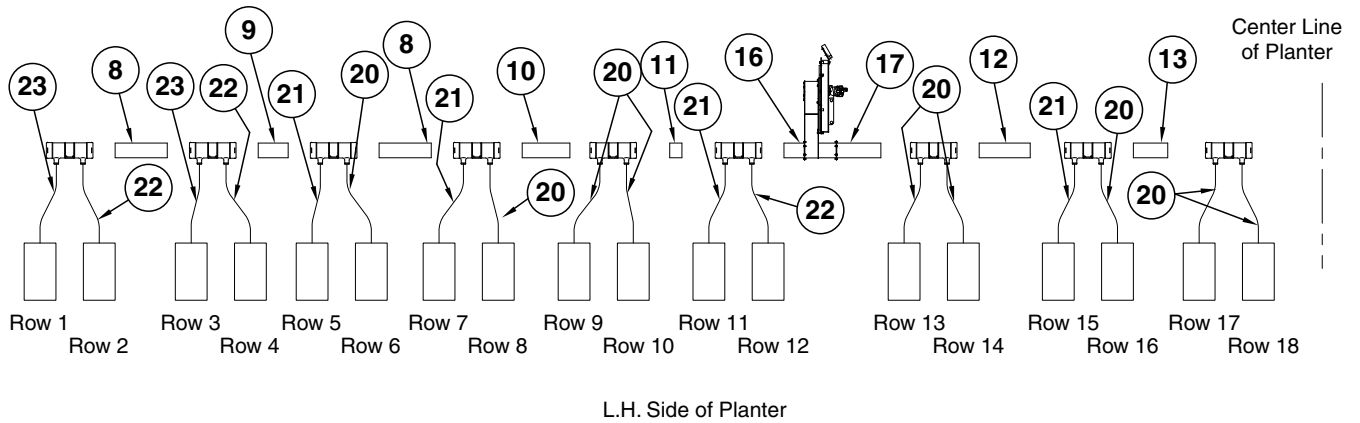
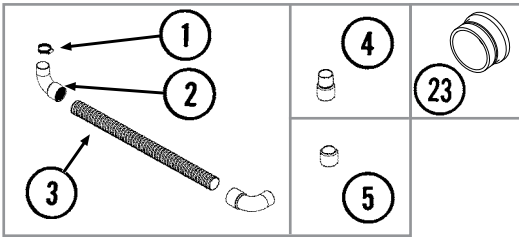

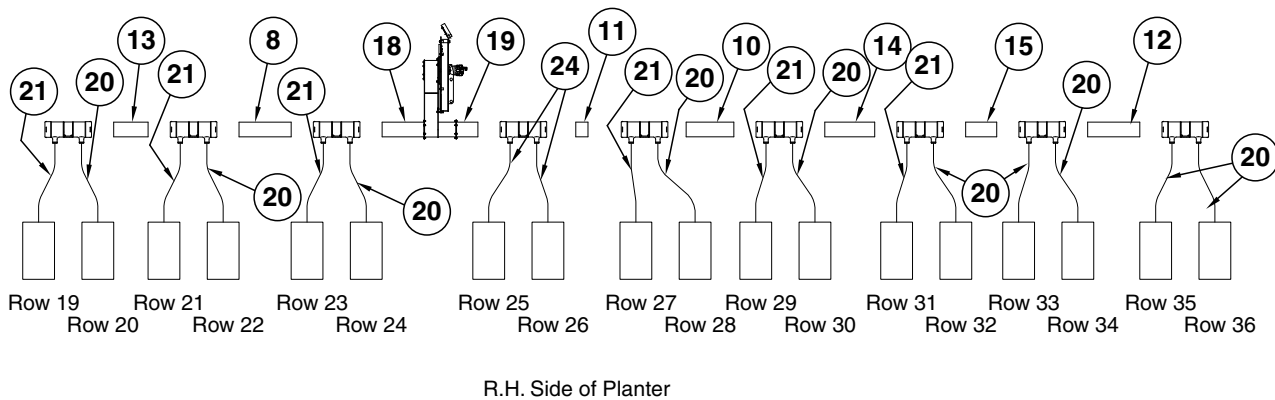

ITEM	PART NO.	QTY.	DESCRIPTION
1	G10676	24	Hose Clamp, No. 36, Stainless Steel
2	GD14626	32	Elbow, 90°, 2"
3	---	-	See items 18-22
4	GD14627	16	Coupler, 2"
5	G11147	-	Cap, 2"
6	GD15856-23	3	Hose, 2" x 34"
7	GD15856-14	1	Hose, 2" x 46"
8	GD15856-21	2	Pipe, 6" x 21½"
9	GD15856-22	2	Hose, 2" x 58"
10	GD15856-15	2	Pipe, 6" x 23"
11	GD15856-24	2	Pipe, 6" x 15½"
12	GD15856-20	1	Pipe, 6" x 22¼"
13	GD15856-01	1	Pipe, 6" x 14"
14	GA12100	1	Manifold Flange, 9¼"
15	GA12101	1	Manifold Flange, 20"
16	GA11999	1	Manifold Flange, 19"
17	GA11998	1	Manifold Flange, 9¾"
18	GD15792-20	19	Hose, 2" x 32"
19	GD15792-23	10	Hose, 2" x 34"
20	GD15792-04	3	Hose, 2" x 36"
21	GD15792-24	2	Hose, 2" x 40"
22	GD15792-14	2	Hose, 2" x 46"
23	GD17052	-	Vacuum Plug

(FF108bb)

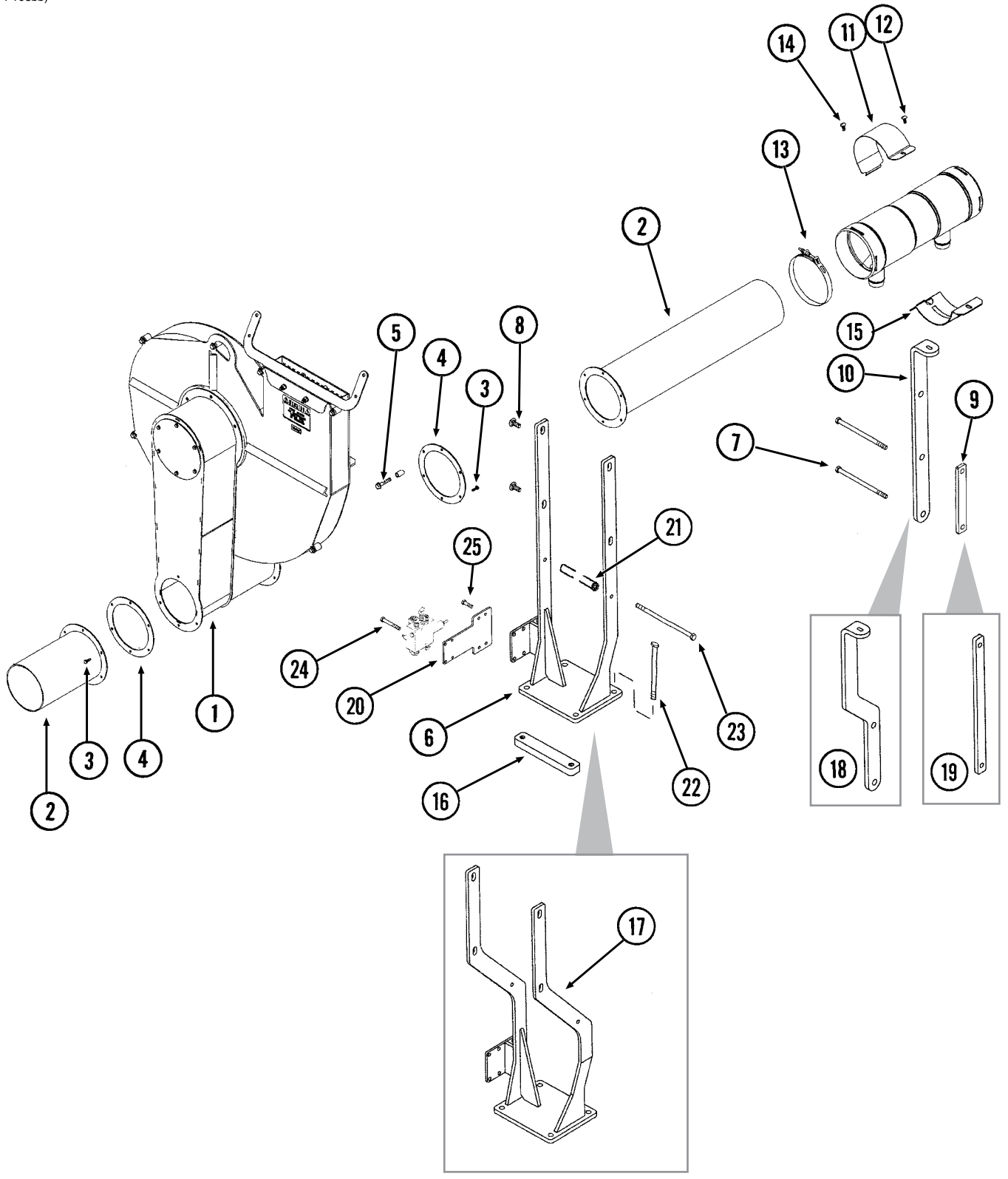

ITEM	PART NO.	QTY.	DESCRIPTION
1	---	-	<a href="#">See "Vacuum System" on page P41</a>
2	---	-	<a href="#">See "Manifolds and Distribution Hoses, 24 Row 30" on page P49</a> <a href="#">See "Manifolds and Distribution Hoses, 36 Row 20" on page P51</a>
3	G10023	-	Hex Head Cap Screw, 1/4"-20 x 3/4"
	G10110	-	Lock Nut, 1/4"-20, Grade B
4	GD16842	2	Manifold Gasket, 1/8" x 8 3/8" (6 5/8" I.D.)
5	G11199	1	Whiz Lock Bolt, 3/8"-16 x 2"
	GD8893-07	1	Sleeve, 1" Long
6	GA13181	1	Support
7	G10341	-	Hex Head Cap Screw, 5/8"-11 x 8"
	G10152	-	Hex Head Cap Screw, 5/8"-11 x 9"
8	G10574	4	Carriage Bolt, 1/2"-13 x 1 1/4"
	G10071	4	Serrated Flange Nut, 1/2"-13
9	GD18628	-	Tap Plate, Short
10	GD18626	-	Support
11	GD15854	1	Clamp
12	G10338	-	Carriage Bolt, 5/16"-18 x 1 1/4"
	G10620	-	Serrated Flange Nut, 5/16"-18
13	G11145	-	T-Bolt Clamp, 7"
14	G10133	-	Hex Head Cap Screw, 5/16"-18 x 1 1/2"
	G10232	-	Lock Washer, 5/16"
	G10106	-	Hex Nut, 5/16"-18
15	GA11164	-	Mount
16	GD18624	-	Tap Block
17	GA13203	-	Offset Support
18	GD18625	-	Offset Support
19	GD18627	-	Tap Block, Long
20	GD18622	-	Block Support Plate
21	GD8893-10	-	Sleeve, 9 13/16" Long
22	G10980	-	Hex Head Cap Screw, 1/2"-13 x 5 1/2"
	GD18623	-	Cap Screw, 1/2"-13 x 17"
23	G11257	-	Hex Head Cap Screw, 3/8"-16 x 11 1/2"
	G10108	-	Lock Nut, 3/8"-16
24	G10063	-	Hex Head Cap Screw, 3/8"-16 x 4"
	G10753	-	Hex Head Cap Screw, 3/8"-16 x 4 1/2"
	G10229	-	Lock Washer, 3/8"
	G10101	-	Hex Nut, 3/8"-16
25	G10001	-	Hex Head Cap Screw, 3/8"-16 x 1"
	G10108	-	Lock Nut, 3/8"-16

(IP1106/FF105c)

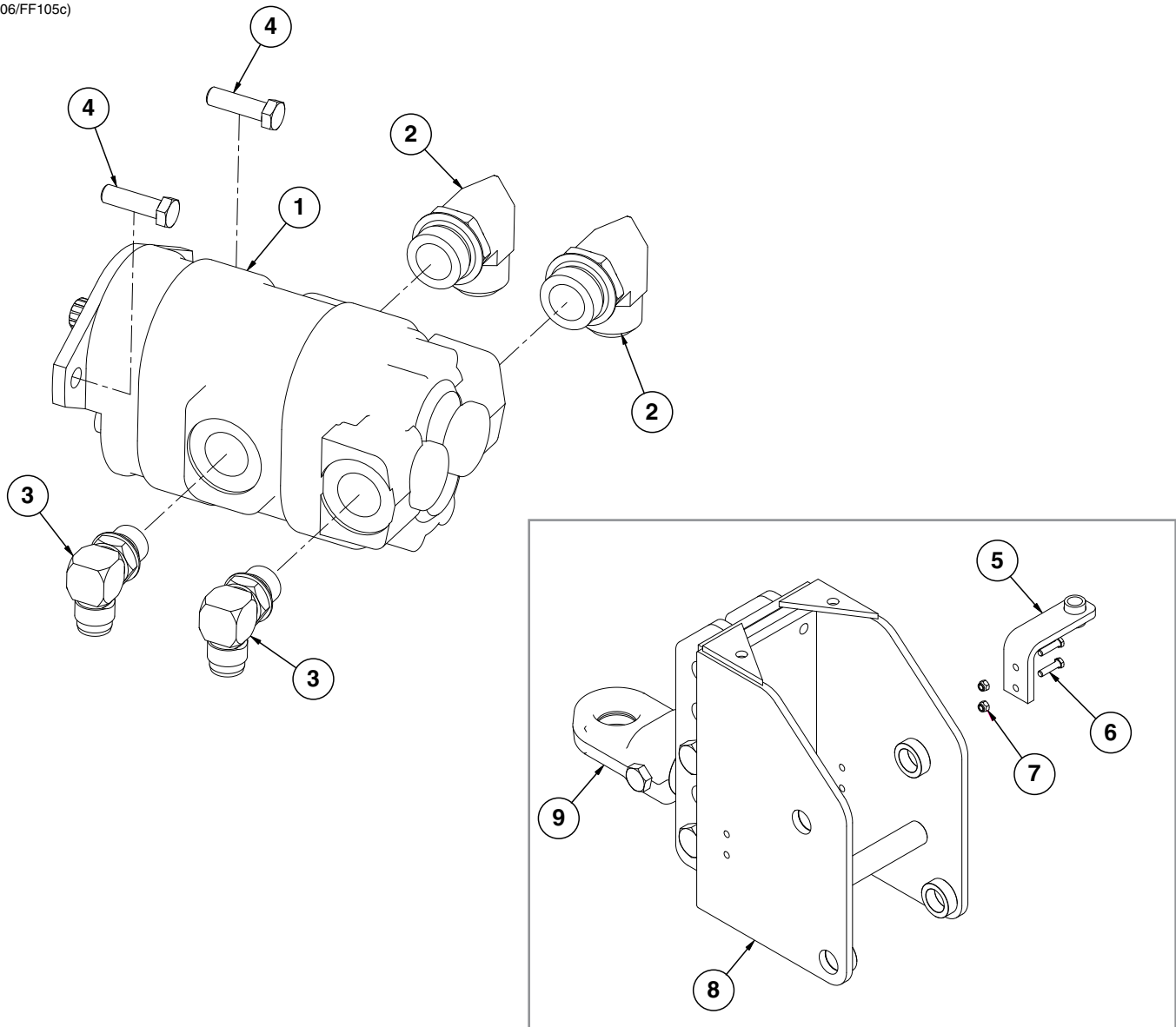

ITEM	PART NO.	QTY.	DESCRIPTION
1	GA13793	1	PTO Pump
2	G6801-20	2	Elbow W/O-Ring, 90°, 1 <sup>5</sup> / <sub>8</sub> "-12 Male JIC To O-Ring
	GR1787	-	O-Ring
3	G6801-12	2	Elbow W/O-Ring, 90°, 1 <sup>1</sup> / <sub>16</sub> "-12 Male JIC To O-Ring
	GR1467	-	O-Ring
4	G11264	2	Hex Head Cap Screw, 1/2"-13, Grade 8
5	A13917	1	Pump Storage
6	G10003	2	Hex Head Cap Screw, 3/8"-16 x 1 1/2"
7	G10108	2	Lock Nut, 3/8"-16
8	---	-	<a href="#">See "Front Hitch Assembly/Safety Chain" on page P83</a>
9	---	-	<a href="#">See "Front Hitch Assembly/Safety Chain" on page P83</a>
A	GR1946	-	Seal Kit

**This page left blank intentionally.**

(IP1304)

ASD Fan Assembly

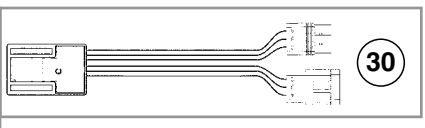
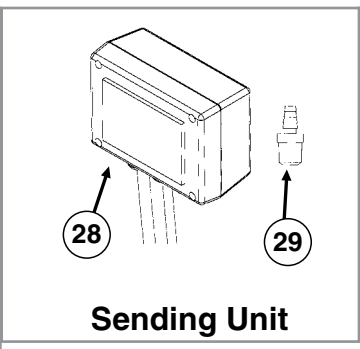
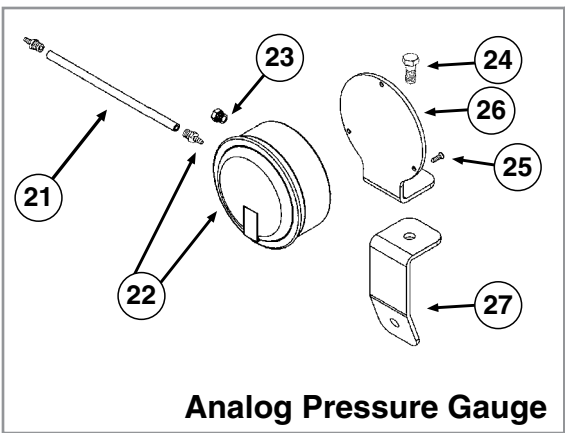
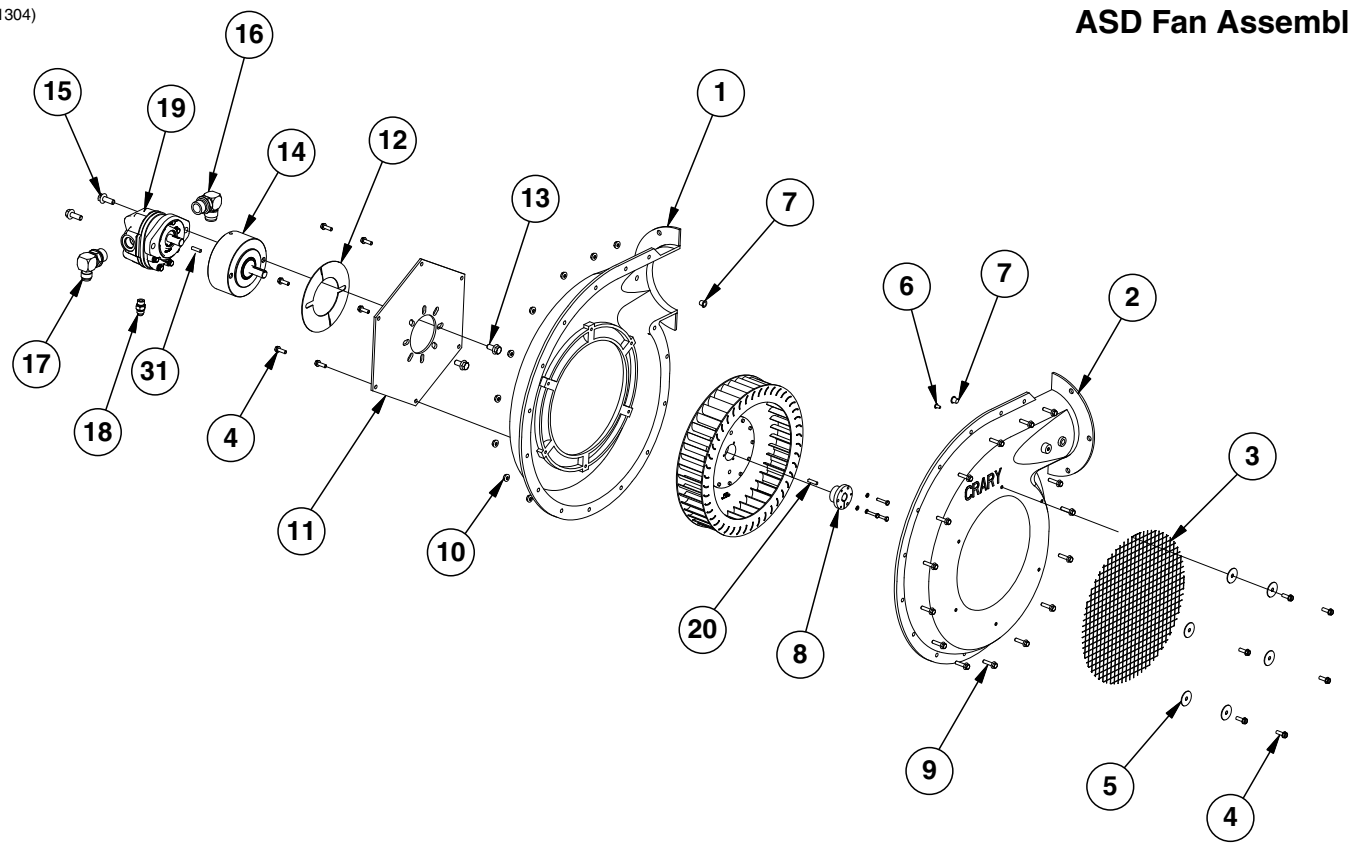

ITEM	PART NO.	QTY.	DESCRIPTION
1	GR1971	1	Flanged Inner Case
2	GR1970	1	Flanged Outer Case
3	GR1967	1	Screen
4	GR1976	12	Hex Flange Self Tapping Screw, 1/4" x 3/4"
5	GR1977	6	Fender Washer, 1/4"
6	GR1978	1	Plastic Plug, 1/4"
7	GR1979	2	Plastic Plug, 7/16"
8	GR1961	1	Bushing, 5/8"
9	G11409	15	Hex Serrated Flanged Cap Screw, 1/4"-20 x 1"
10	G10621	15	Serrated Flange Nut, 1/4"-20
11	GR1969	2	Backing Plate
12	GR1968	2	Cover Plate
13	G11123	2	Hex Serrated Flange Cap Screw, 3/8"-16 x 3/4"
14	GA14575	1	Overhung Load Adapter
15	G11124	2	Hex Serrated Flange Cap Screw, 3/8"-16 x 1"
16	G6801-12	1	Elbow W/O-Ring, 90°, 1 1/16"-12 Male JIC To O-Ring
17	G6801-10-12	1	Elbow W/O-Ring, 90°, 7/8"-14 Male JIC To 1 1/16"-12 O-Ring
18	G6400-06	1	Connector W/O-Ring, 9/16"-18 Male JIC To O-Ring
19	GA14574	1	Hydraulic Motor
20	GD21300	1	Key Stock, 3/16" x 3/4"
21	GD15849-02	1	Clear Plastic Tubing, 5/16" O.D. x 3/16" I.D. x 120"
22	GA10765	1	Analog Vacuum Gauge W/Hose Barb
	GR1777	-	Hose Barb, 1/8" Male NPT To 3/16" Barb
23	GA10799	1	Breather, 1/8" Male NPT
24	G10001	1	Hex Head Cap Screw, 3/8"-16 x 1"
	G10108	1	Lock Nut, 3/8"-16
25	G11215	3	Hex Socket Head Cap Screw, No. 6-32 x 3/8", Grade 8
26	GD15804	1	Mount
27	GD15945	1	Support
28	GA14847	1	Low Pressure Sensor (0-40 IN H2O)
	GD17151-20	-	Tubing, 1/4" x 10'
	GA9964	-	Strain Relief
29	GR1736	1	Hose Barb, 1/8" Male NPT To Barb
30	GA12812	1	Hall Effect Adapter
31	GR2000	1	Hydraulic Motor Key
A	GR1960	-	ASD Fan Motor Seal Kit
B	GA14573	-	ASD Fan Assembly (Flanged) (Items 1-7 and 9-12)

(IP1302)

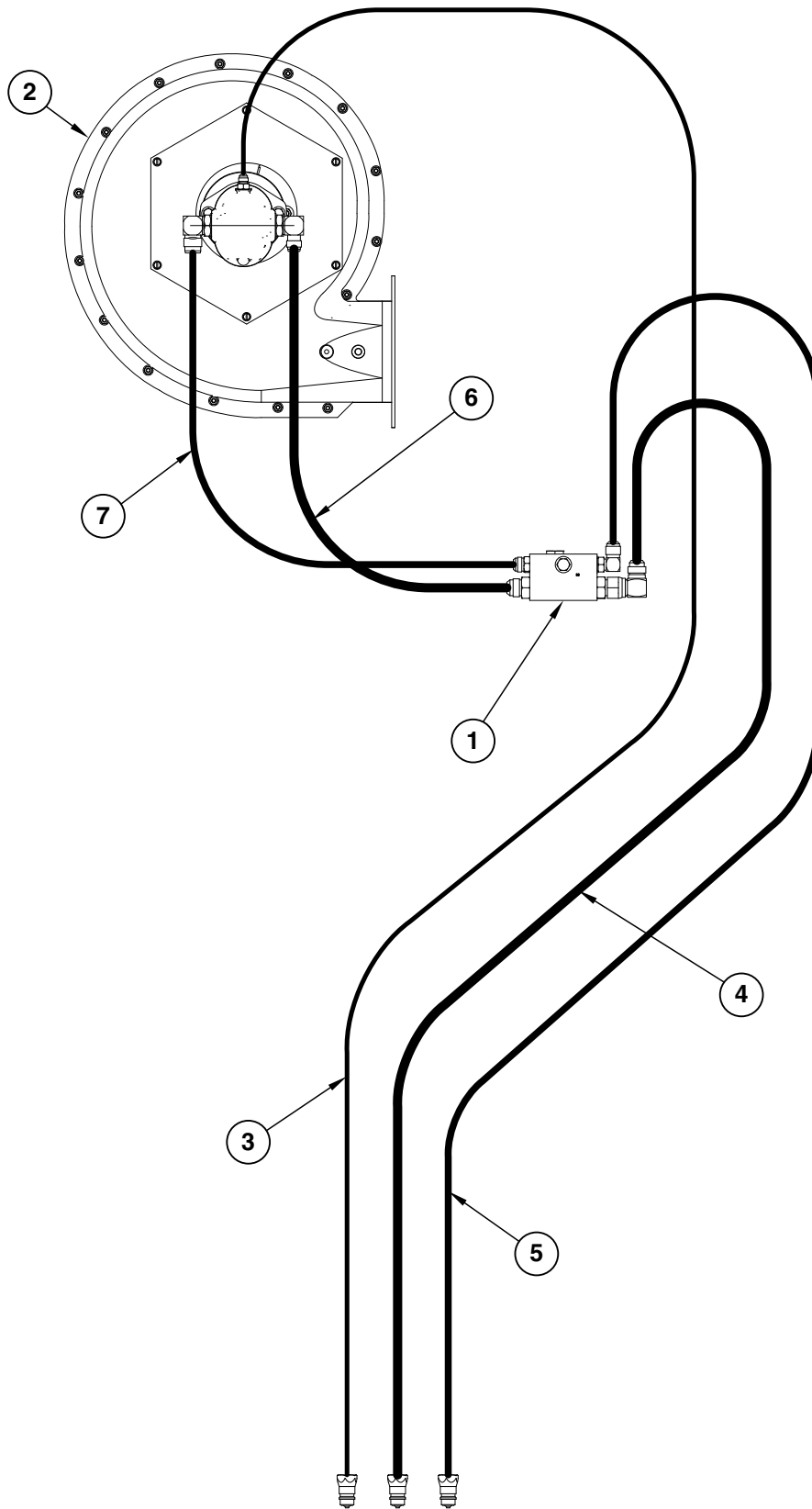

---

ITEM	PART NO.	QTY.	DESCRIPTION
1	---	-	<a href="#">See "ASD Fan System" on page P57</a>
2	---	-	<a href="#">See "ASD Fan System" on page P57</a>
3	*A15004	1	Hose Assembly, 3/8" x 120"
4	*A3368	1	Hose Assembly, 3/4" x 86"
5	*A8274	1	Hose Assembly, 1/2" x 86"
6	*A3353	1	Hose Assembly, 3/4" x 33"
7	*A1424	1	Hose Assembly, 1/2" x 30"

\*Hydraulic hose is not stocked by Kinze Repair Parts, but can be made available on a special order basis. Call for quote.

(IP1144)

R.H. Rear of Machine

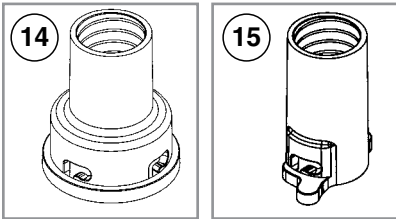
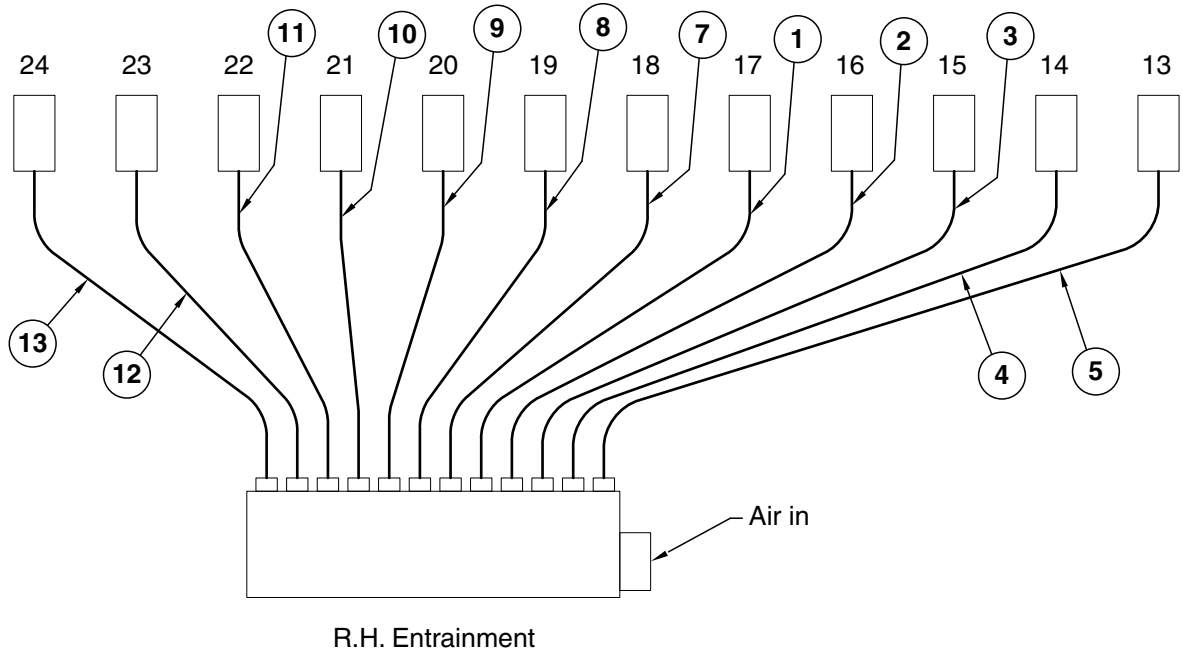

ITEM	PART NO.	QTY.	DESCRIPTION
1	GA13800	1	Seed Hose Assembly, 1 1/4" x 218"
2	GA13801	2	Seed Hose Assembly, 1 1/4" x 192"
3	GA13802	2	Seed Hose Assembly, 1 1/4" x 161"
4	GA13803	2	Seed Hose Assembly, 1 1/4" x 133"
5	GA13804	2	Seed Hose Assembly, 1 1/4" x 101"
6	GA13810	1	Seed Hose Assembly, 1 1/4" x 225"
7	GA13817	2	Seed Hose Assembly, 1 1/4" x 246"
8	GA13818	2	Seed Hose Assembly, 1 1/4" x 280"
9	GA13819	2	Seed Hose Assembly, 1 1/4" x 313"
10	GA13820	2	Seed Hose Assembly, 1 1/4" x 340"
11	GA13821	2	Seed Hose Assembly, 1 1/4" x 371"
12	GA13822	2	Seed Hose Assembly, 1 1/4" x 403"
13	GA13823	2	Seed Hose Assembly, 1 1/4" x 428"
14	GB0425	-	Dissipator Quick Coupler
15	GB0429	-	Seed Entrainer Quick Coupler

L.H. Rear of Machine

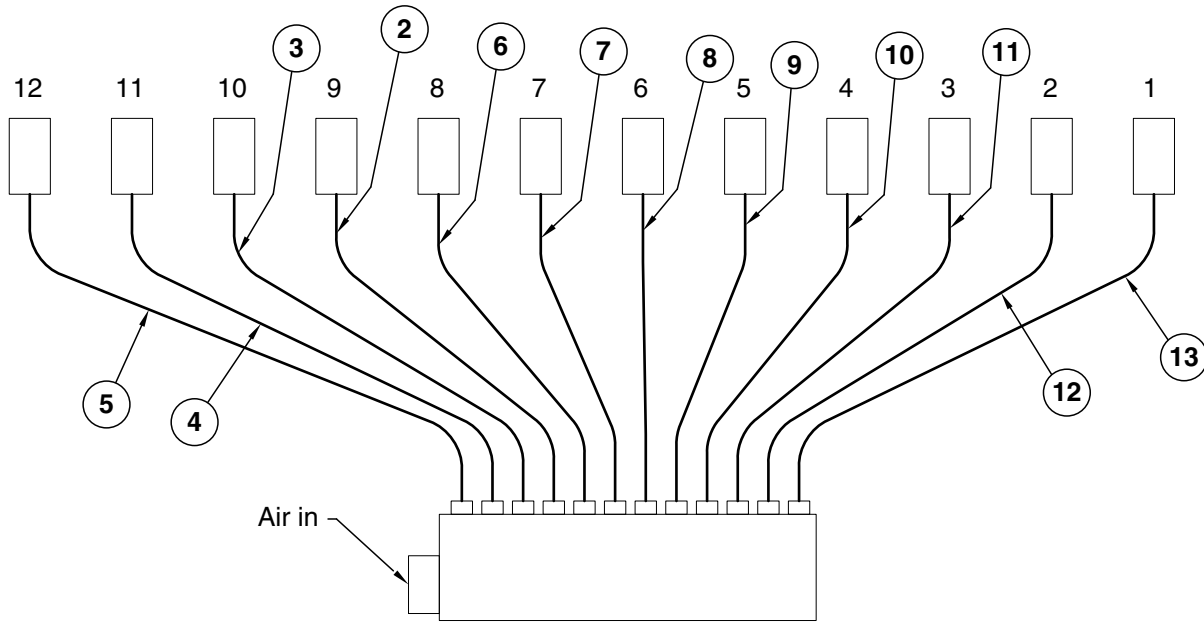

L.H. Entrainment

(IP1153)

R.H. Rear of Machine

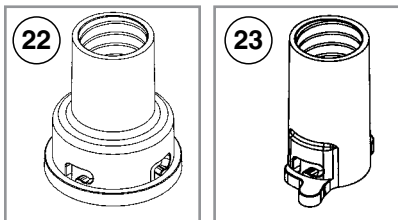
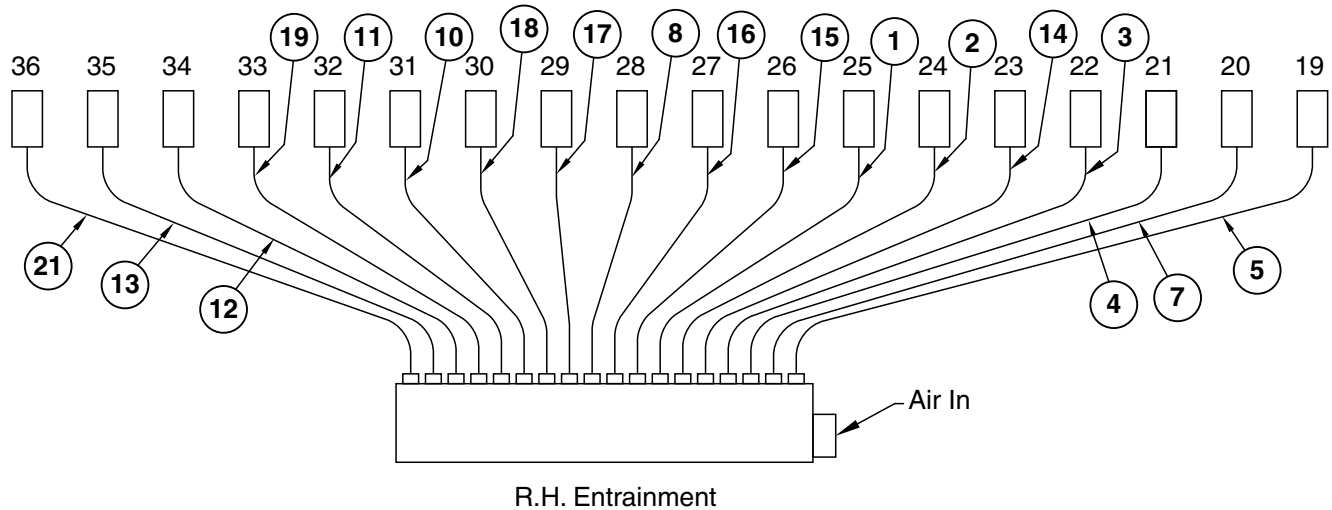

ITEM	PART NO.	QTY.	DESCRIPTION
1	GA13800	2	Seed Hose Assembly, 1 1/4" x 218"
2	GA13801	2	Seed Hose Assembly, 1 1/4" x 192"
3	GA13802	2	Seed Hose Assembly, 1 1/4" x 161"
4	GA13803	2	Seed Hose Assembly, 1 1/4" x 133"
5	GA13804	2	Seed Hose Assembly, 1 1/4" x 101"
6	GA13824	1	Seed Hose Assembly, 1 1/4" x 103"
7	GA13825	1	Seed Hose Assembly, 1 1/4" x 116"
8	GA13818	2	Seed Hose Assembly, 1 1/4" x 280"
9	GA13819	2	Seed Hose Assembly, 1 1/4" x 313"
10	GA13820	2	Seed Hose Assembly, 1 1/4" x 340"
11	GA13821	2	Seed Hose Assembly, 1 1/4" x 371"
12	GA13822	2	Seed Hose Assembly, 1 1/4" x 403"
13	GA13823	2	Seed Hose Assembly, 1 1/4" x 428"
14	GA13826	2	Seed Hose Assembly, 1 1/4" x 176"
15	GA13827	2	Seed Hose Assembly, 1 1/4" x 235"
16	GA13828	2	Seed Hose Assembly, 1 1/4" x 262"
17	GA13829	2	Seed Hose Assembly, 1 1/4" x 301"
18	GA13830	2	Seed Hose Assembly, 1 1/4" x 320"
19	GA13831	2	Seed Hose Assembly, 1 1/4" x 380"
20	GA13832	1	Seed Hose Assembly, 1 1/4" x 438"
21	GA13833	1	Seed Hose Assembly, 1 1/4" x 450"
22	GB0425	-	Dissipator Quick Coupler
23	GB0429	-	Seed Entrainer Quick Coupler

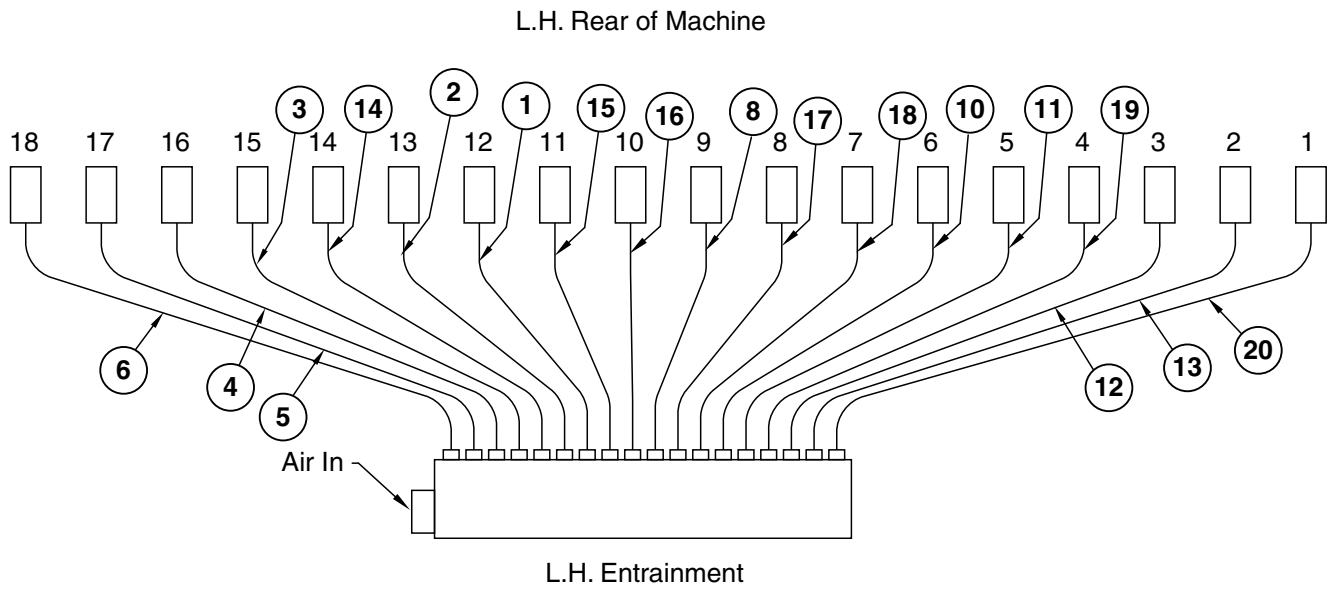

(IP1170)

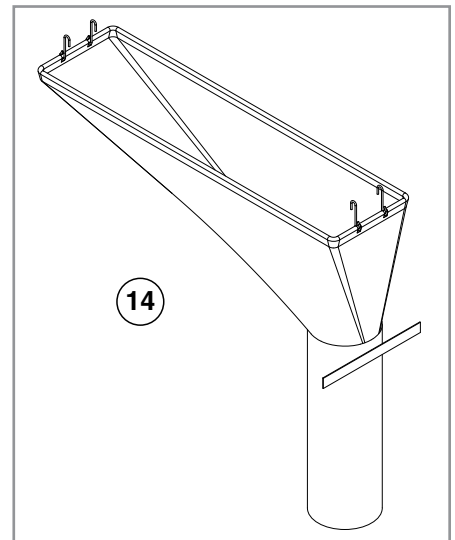
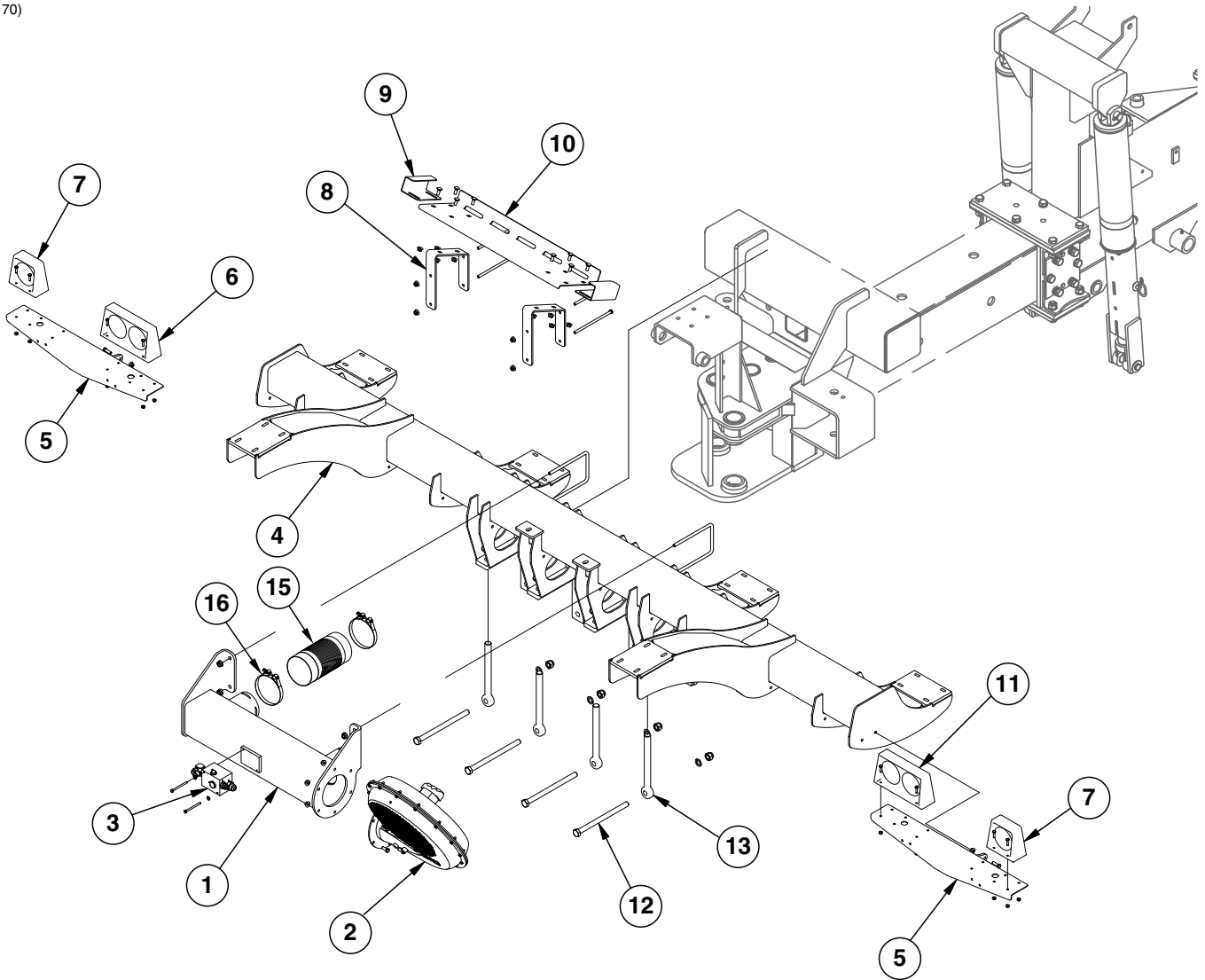

ITEM	PART NO.	QTY.	DESCRIPTION
1	GA14082	1	Fan Mount
	GD8306	2	U-Bolt, 7" x 5" x 1/2"-13
	G10071	4	Serrated Flange Nut, 1/2"-13
2	GA13317	1	<a href="#">See "ASD Fan System" on page P57</a>
	G11091	6	Serrated Flange Nut, 3/8"-16
	G10001	6	Hex Head Cap Screw, 3/8"-16 x 1"
	GR1777	1	Hose Barb, 1/8" Male NPT To 3/16" Barb
3	GA13421	1	ASD Fan Block
	G10211	2	Washer, 1/4" SAE
	G10162	2	Hex Head Cap Screw, 1/4"-20 x 3/4"
4	GA14084	1	Tank Frame
5	GA14051	2	Light Bracket
	G10004	4	Hex Head Cap Screw, 3/8"-16 x 1 1/4"
	G11091	4	Serrated Flange Nut, 3/8"-16
6	GA6700	1	<a href="#">See "Electrical Components" on page P163</a>
	G10621	4	Serrated Flange Nut, 1/4"-20
	G10064	4	Hex Head Cap Screw, 1/4"-20 x 1"
7	GA6701	2	<a href="#">See "Electrical Components" on page P163</a>
	G10621	8	Serrated Flange Nut, 1/4"-20
	G10064	8	Hex Head Cap Screw, 1/4"-20 x 1"
8	GD20195	2	Mounting Bracket
	G10686	4	Hex Head Cap Screw, 3/8"-16 x 8"
	G11091	4	Serrated Flange Nut, 3/8"-16
9	GD20196	2	Clean Out Chute Clip
	G10305	4	Carriage Bolt, 3/8"-16 x 1"
	G11091	4	Serrated Flange Nut, 3/8"-16
10	GD20194	1	Clean Out Chute Plate
	G10305	4	Carriage Bolt, 3/8"-16 x 1"
	G11091	4	Serrated Flange Nut, 3/8"-16
11	GA6699	1	<a href="#">See "Electrical Components" on page P163</a>
	G10621	4	Serrated Flange Nut, 1/4"-20
	G10064	4	Hex Head Cap Screw, 1/4"-20 x 1"
12	G10541	4	Hex Head Cap Screw, 3/4"-10 x 11"
	GD2169	4	Special Washer, 25/32" I.D. x 1 1/4" O.D., Hardened
	G10112	4	Lock Nut, 3/4"-10
13	GD20275	4	Eye Bolt, 1-14" x 11"
	G11394	4	Flat Washer, 1" SAE
	G11108	4	Lock Nut, 1"-14
14	GA14078	-	Cleanout Chute, 24 Row
	GA14128	-	Cleanout Chute, 36 Row
15	GD19659-03	2	Hose, 4 1/2" x 49"
16	G11360	4	T-Bolt Hose Clamp, 4 1/2"

(IP1124)

R.H. Shown

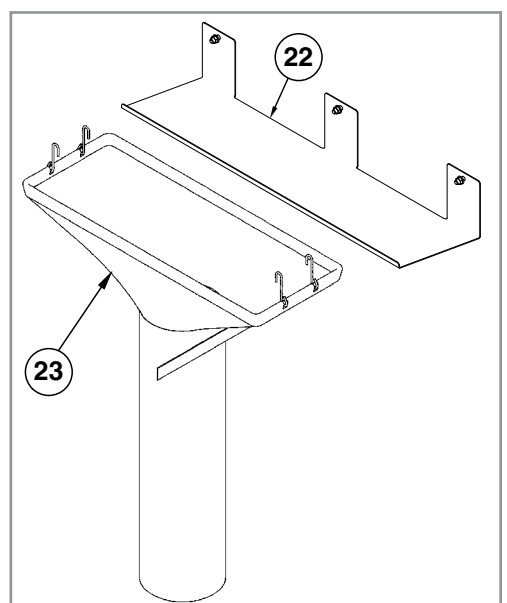
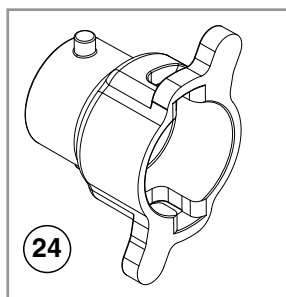
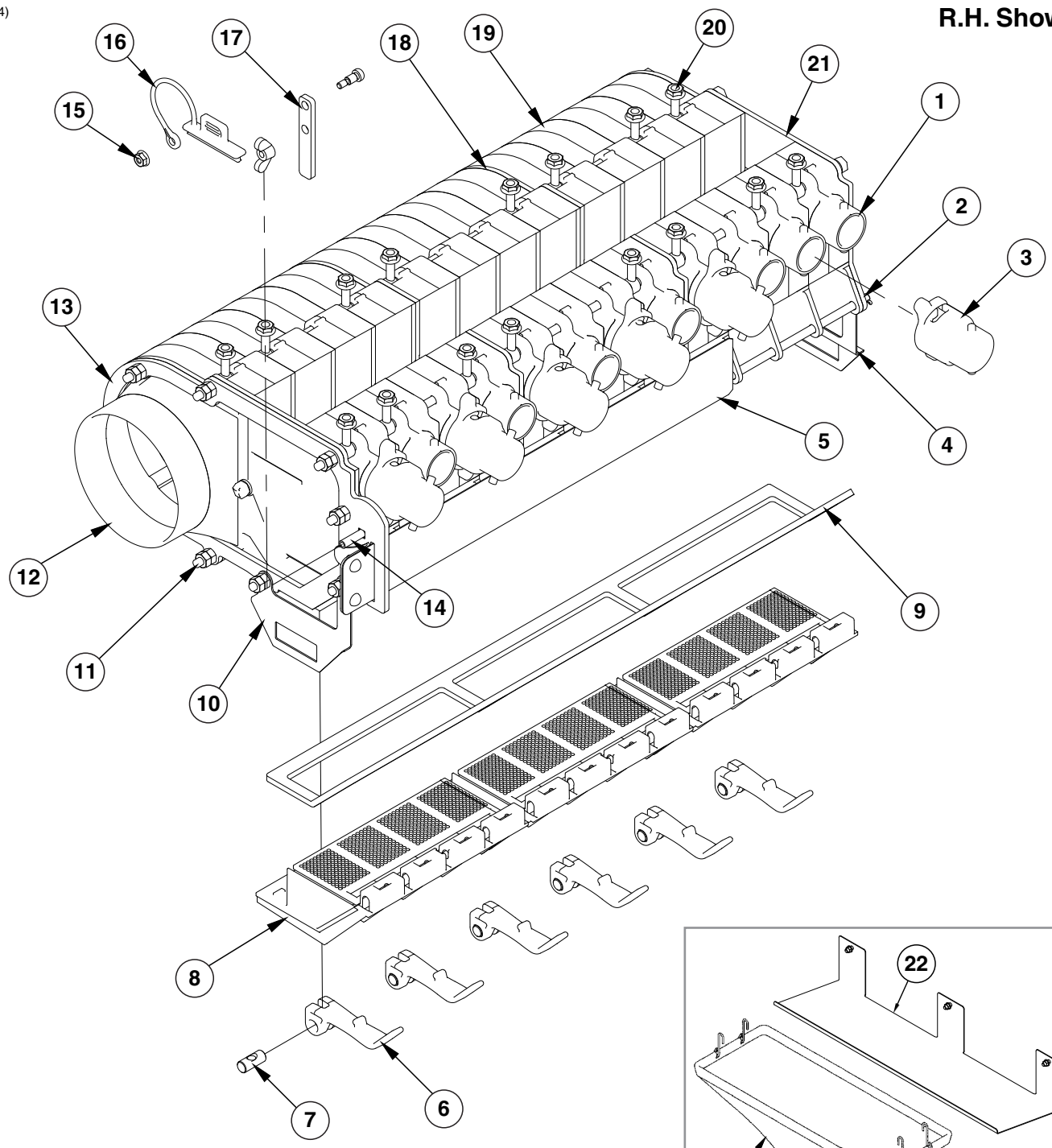

ITEM	PART NO.	QTY.	DESCRIPTION
1	GB0433	3	ASD Seed Entrainer Door Section
2	GD19854	1	ASD Cleanout Door Hinge Rod, 12 Row
	G10455	2	Cotter Pin, 1/16" x 1/2"
3	GB0431	6	ASD Small Cap (If Applicable)
	GD19508	6	Small O-Ring
4	GD19698	1	ASD Chute Hanger, R.H.
5	GA14942	1	ASD Shutoff Door
6	GB0501	6	Latch Handle
	GD19864	6	Eye Bolt, 1/4"-20 x 1.83"
7	GD21080	6	Cam Nut, 1/4"-20
8	GB0502	3	ASD Cleanout Door
9	GD19863	1	ASD Cleanout Door Gasket, 12 Row
10	GD19699	1	ASD Chute Hanger, L.H.
11	GD19852	10	Hex Head Cap Screw, 1/4"-20 x 22"
	G11328	11	Washer, 1/4"
	G10103	21	Lock Nut, 1/4"-20, Grade B
12	GB0436	1	ASD Seed Entrainer Air Inlet, R.H. (Shown)
	GB0435	-	ASD Seed Entrainer Air Inlet, L.H.
13	GD19635	1	ASD Retainment Ring
14	G10316	1	Carriage Bolt, 1/4"-20 x 1"
	G10531	1	Wing Nut W/Nylon Insert, 1/4"-20
15	G10992	1	Serrated Flange Nut, No. 10-24
	G11332	1	Hex Socket Head Set Screw, 1/4" x No. 10-24 x 3/8"
	G11302	1	Hex Nut, 1/4"-20
16	GB0444	2	ASD Shutoff Door Plug
17	GD19695	1	ASD Slide Latch
18	GD19665	2	ASD Spacer Plate
19	GB0427	9	ASD Seed Entrainer
20	GD19865	16	Eye Bolt, 1/4"-20 x 1.47"
	G10621	16	Serrated Flange Nut, 1/4"-20
21	GB0434	1	ASD Seed Entrainer End Cap
22	GD19808	1	Cleanout Chute Storage Bracket
	G10001	3	Hex Head Cap Screw, 3/8"-16 x 1"
	G10622	3	Serrated Flange Nut, 3/8"-16
23	GA14822	1	Cleanout Chute
24	GB0430	-	ASD Large Cap
A	GA14004	-	ASD Entrainer Assembly, R.H. (Shown) (Items 1-21)
B	GA14005	-	ASD Entrainer Assembly, L.H. (Items 1-21)

(IP1172)

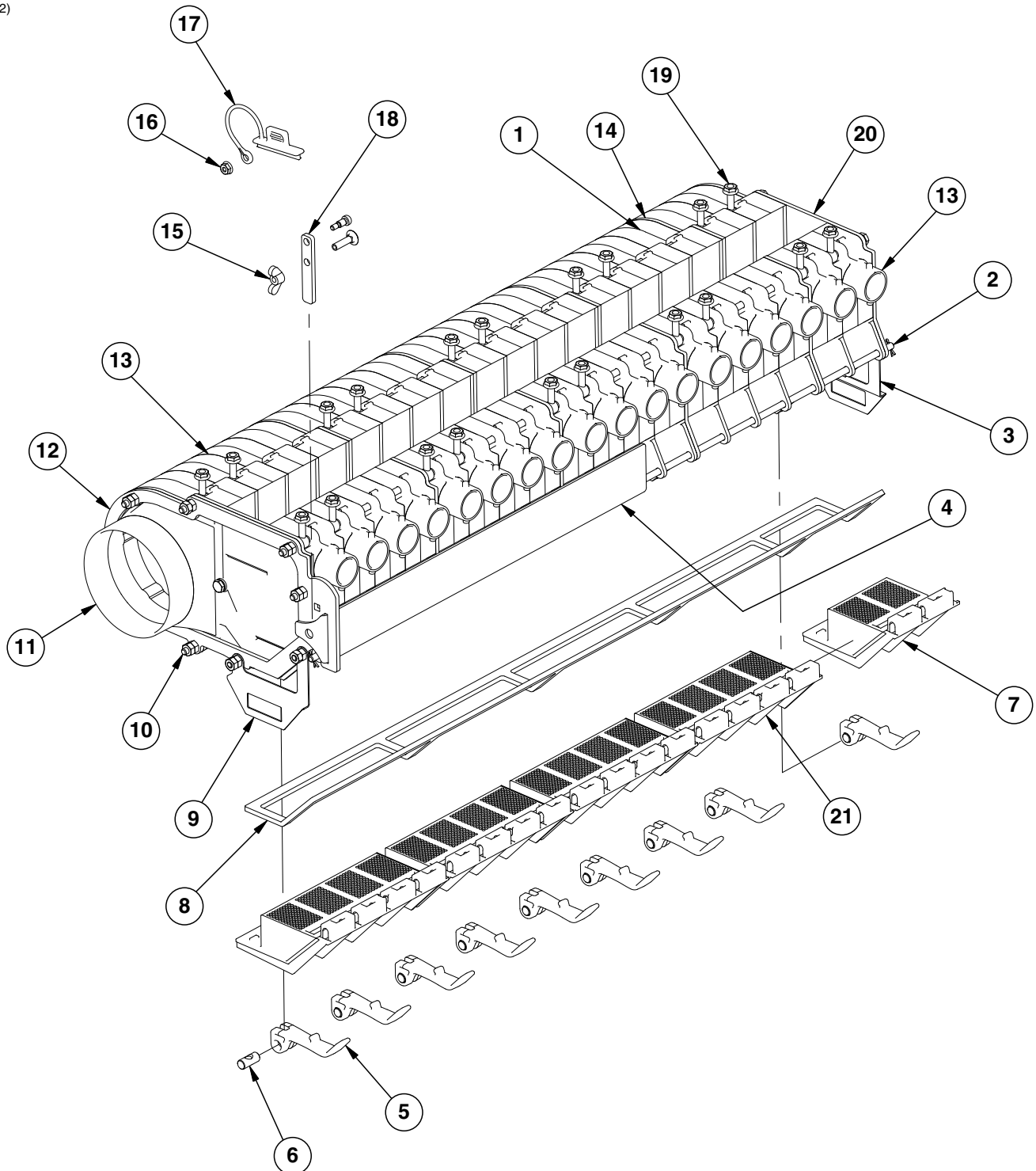

ITEM	PART NO.	QTY.	DESCRIPTION
1	GB0433	4	ASD Seed Entrainer Door Section
2	GD19855	1	ASD Cleanout Door Hinge Rod, 18 Row
	G10455	2	Cotter Pin, 1/16" x 1/2"
3	GD19698	1	ASD Chute Hanger, R.H.
4	GD20145	1	ASD Shutoff Door
5	GB0501	9	Latch Handle
	GD19864	9	Eye Bolt, 1/4"-20 x 1.83"
6	GD21080	9	Cam Nut, 1/4"-20
7	GD21186	1	ASD Cleanout Door, Half
8	GD20041	1	ASD Cleanout Door Gasket, 18 Row
9	GD19699	1	ASD Chute Hanger, L.H.
10	GD19853	10	Hex Head Cap Screw, 1/4"-20 x 32 1/2"
	G11328	11	Washer, 1/4"
	G10103	21	Hex Nut, 1/4"-20
11	GB0436	1	ASD Seed Entrainer Air Inlet, R.H. (Shown)
	GB0435	-	ASD Seed Entrainer Air Inlet, L.H.
12	GD19635	1	ASD Retainment Ring
13	GB0427	14	ASD Seed Entrainer
14	GD19665	4	ASD Spacer Plate
15	G10531	1	Wing Nut W/Nylon Insert, 1/4"-20
	G10316	1	Carriage Bolt, 1/4"-20 x 1"
16	G10992	1	Serrated Flange Nut, No. 10-24
	G11332	1	Hex Socket Head Set Screw, 1/4" x No. 10-24 x 3/8"
17	GB0444	2	ASD Shutoff Door Plug
18	GD19695	1	ASD Slide Latch
19	G10621	20	Serrated Flange Nut, 1/4"-20
	GD19865	20	Eye Bolt, 1/4"-20 x 1.47"
20	GB0434	1	ASD Seed Entrainer End Cap
21	GB0502	4	ASD Cleanout Door
A	GA14108	-	ASD Entrainer Assembly, R.H. (Shown) (Items 1-21)
B	GA14109	-	ASD Entrainer Assembly, L.H. (Items 1-21)

(IP1151)

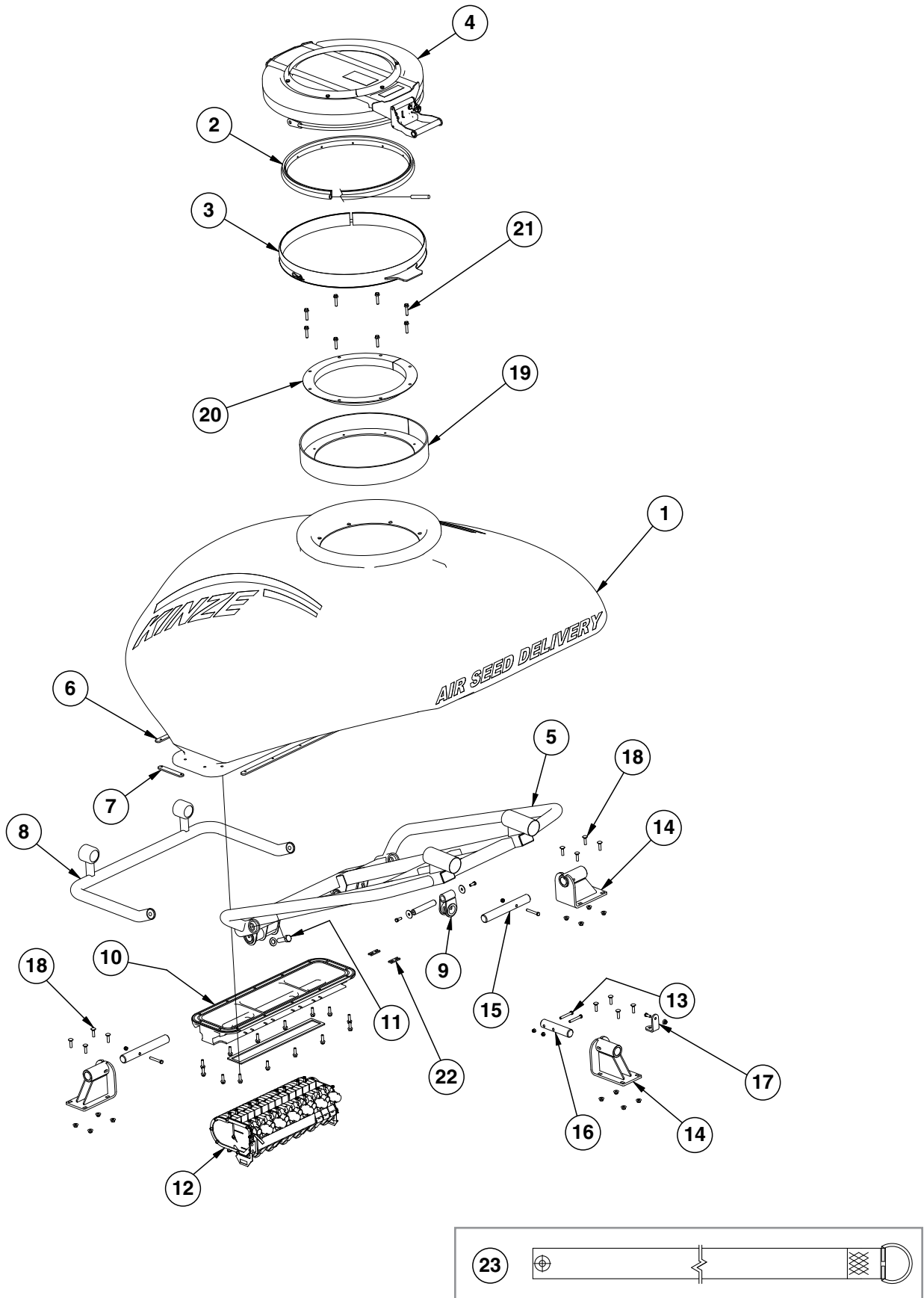

ITEM	PART NO.	QTY.	DESCRIPTION
1	GD19894	1	ASD Tank
2	GD21081	1	ASD Tank Lid Seal
	GD21140	1	Foam Seal Connector
3	GA14092	1	ASD Lid Rim
	G10592	2	Hair Pin Clip, No. 11
	G10053	1	Hex Head Cap Screw, 1/2"-13 x 2 1/2"
	G10111	1	Lock Nut, 1/2"-13
4	GA14707	1	ASD Lid Assembly (also includes item no. 2)
	GA14089	1	Latch Handle
	GD20022	1	Latch Mount Bracket
	GD20030	1	Pivot Bail Bracket
	G10328	2	Hex Head Cap Screw, 3/8"-16 x 5/8"
	G11387	2	Flat Washer, 3/8" SAE
5	GA14037	1	ASD Rear Tank Frame
6	GD20922	2	Entrainer Mount Tap Block, Long
7	GD20923	2	Entrainer Mount Tap Block, Short
8	GA14038	1	ASD Front Tank Frame
9	GA14040	1	ASD Rear Tank Mount
	GD20037	1	Pin, 1" x 5 3/8"
	G10201	2	Special Washer, 3/8" x 1 1/2" O.D.
	G10001	2	Hex Head Cap Screw, 3/8"-16 x 1"
10	GD19956	1	ASD Entrainment Mounting Plate, 12 Row (Shown)
	GD19958	-	ASD Entrainment Mounting Plate, 18 Row
	GD19893	1	ASD Tank Mount Gasket, 12 Row
	GD20040	-	ASD Tank Mount Gasket, 18 Row
	GD19690-03	1	Ribbon Sealer, 6 1/2'
	GD19690-04	1	Ribbon Sealer, 7'
	G11204	14	Flanged Whiz Lock Screw, 3/8"-16 x 1 1/4", Serrated
11	G10027	2	Hex Head Cap Screw, 3/4"-10 x 2 1/2"
	G11392	2	Flat Washer, 3/4" SAE
12	---	1	<a href="#">See "ASD Entrainer Assembly, 24 Row 30" on page P68</a> <a href="#">See "ASD Entrainer Assembly, 36 Row 20" on page P69</a>
13	G10325	4	Hex Head Cap Screw, 3/8"-16 x 2 3/4"
	G10108	4	Lock Nut, 3/8"-16
14	GA15420	3	ASD Tank Mount
15	GD20035	2	Pin, 1 1/2" x 1 1/4"
16	GD20036	1	Pin, 1 1/2" x 7"
17	GD20248	1	Seed Hose Strap Bracket
	G10001	1	Hex Head Cap Screw, 3/8"-16 x 1"
	G11091	13	Serrated Flange Nut, 3/8"-16
18	G10301	12	Carriage Bolt, 3/8"-16 x 1 1/2"
19	GA14839	1	Clamp Ring
20	GD21174	1	Outer Clamp Ring
21	G11411	8	Hex Serrated Flange Cap Screw, 3/8"-16 x 1 3/4"
22	GD21308	2	Bolt Holder
23	GA14152	-	Seed Hose Strap
A	GA14003	-	ASD Tank Assembly, 12 Row (Items 1-11 and 19-21)
B	GA14236	-	ASD Tank Assembly, 18 Row (Items 1-11 and 19-21)

(IP1192)

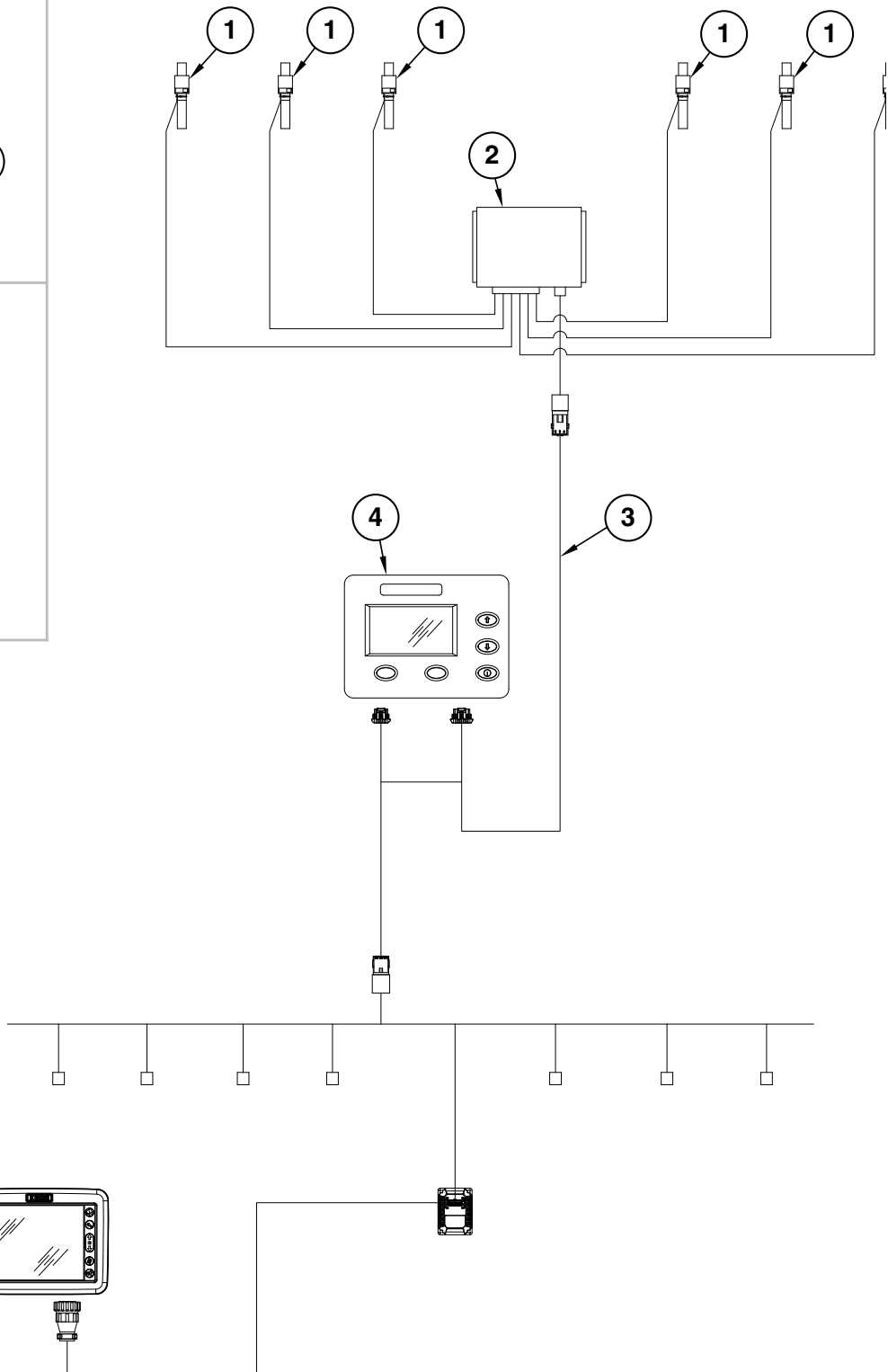
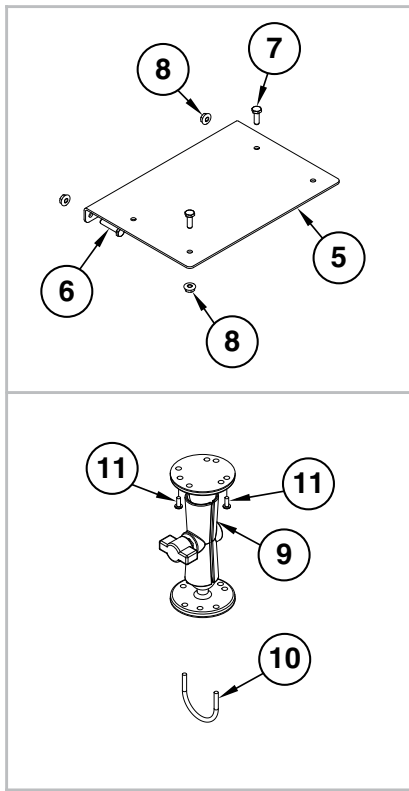

ITEM	PART NO.	QTY.	DESCRIPTION
1	GA14135	6	Load Cell
2	GA14136	1	Scale Module
3	GA14129	1	Power Cable
4	GA14133	1	ASD Scale Display
5	GD20281	1	Scale Module Mounting
6	G10857	2	Hex Head Cap Screw, ¼"-20 x 1¼"
7	G10023	2	Hex Head Cap Screw, ¼"-20 x ¾"
8	G10621	4	Serrated Flange Nut, ¼"-20
9	GA12403	1	Mounting Bracket Assembly, Includes: (2) Mounting Brackets, (2) Connector Halves, (1) Compression Spring, (1) Tension Knob, (1) ¼"-20 x 1¾" Hex Head Cap Screw, (1) ¼" Plastic Washer, (1) ¼" Steel Washer
10	GD20282	1	U-Bolt, #10-32
	G11284	2	Serrated Flange Nut, #10-32
11	G11216	2	Phillips Pan Head Machine Screw, No. 10-32 x ½", Stainless Steel

(IP1156)

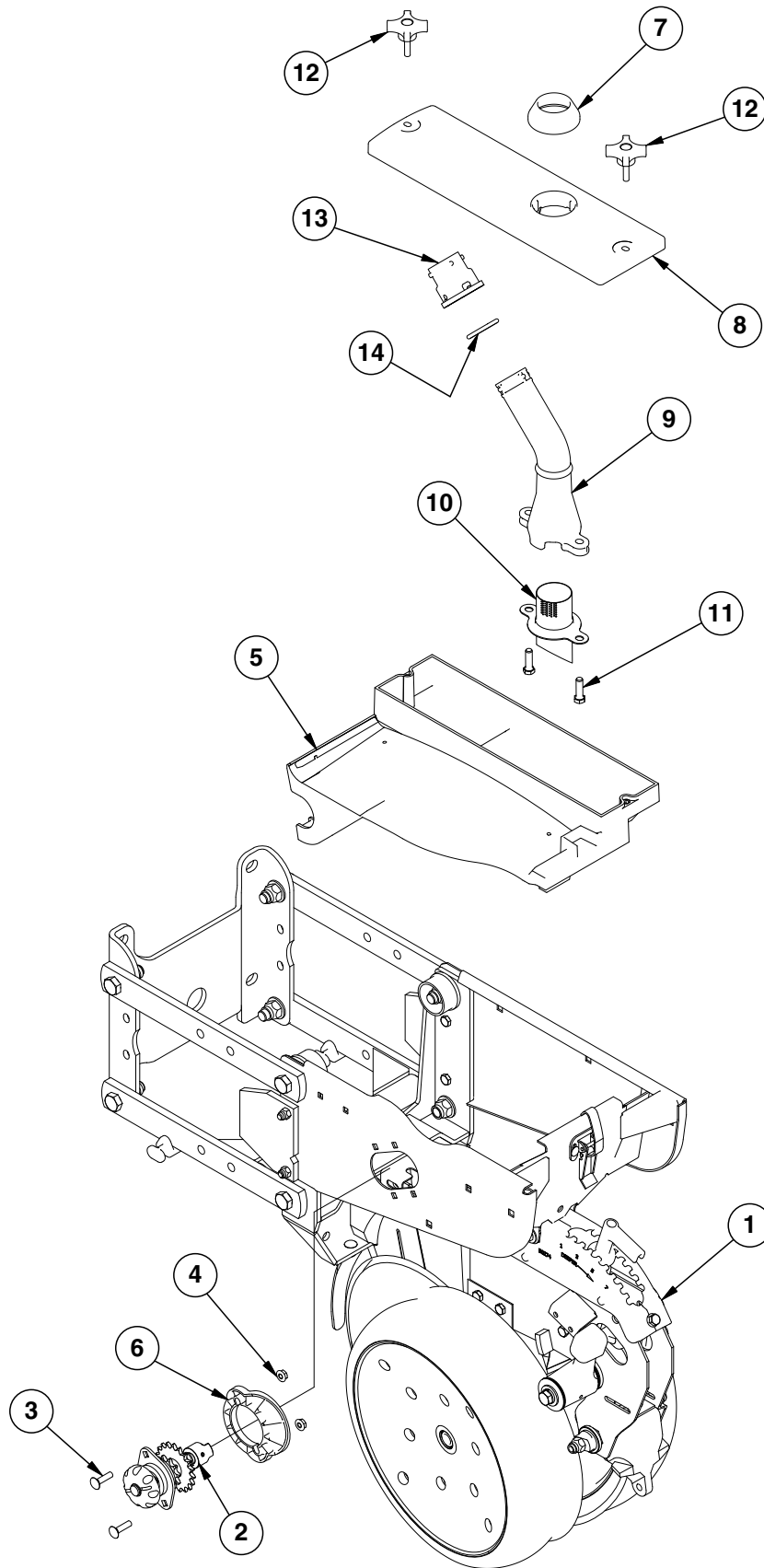

ITEM	PART NO.	QTY.	DESCRIPTION
1	---	-	<a href="#">See "Shank Assembly, Seed Tube, and Depth Adjustment" on page P1</a> <a href="#">See "Parallel Arms, Mounting Support Plate, and Quick Adjustable Down Forces Springs Option" on page P7</a> <a href="#">See "Hopper Support and Meter Drive" on page P15</a>
2	GA10151	1	Meter Drive Assembly Complete, 11/19 Tooth
3	G10338	2	Carriage Bolt, 5/16"-18 x 1 1/4"
4	G10620	2	Serrated Flange Nut, 5/16"-18
5	GA9547	1	Mini Hopper
6	GB0331	1	Clutch Adapter Plate
	GA14031	1	ASD Mechanical Meter Cover
7	GB0446	1	ASD Mechanical Meter Cover Seal
8	GB0445	1	ASD Mechanical Meter Cover
9	GB0455	1	ASD Air Pressure Dissipator
10	GB0574	1	Air Dissipator Screen
11	G10004	2	Hex Head Cap Screw, 3/8"-16 x 1 1/4"
12	GD20032	2	Knob, 5/16"-18 x 1 1/4"
13	GB0430	1	ASD Large Cap
14	GD19509	1	O-Ring, Large

(IP1171)

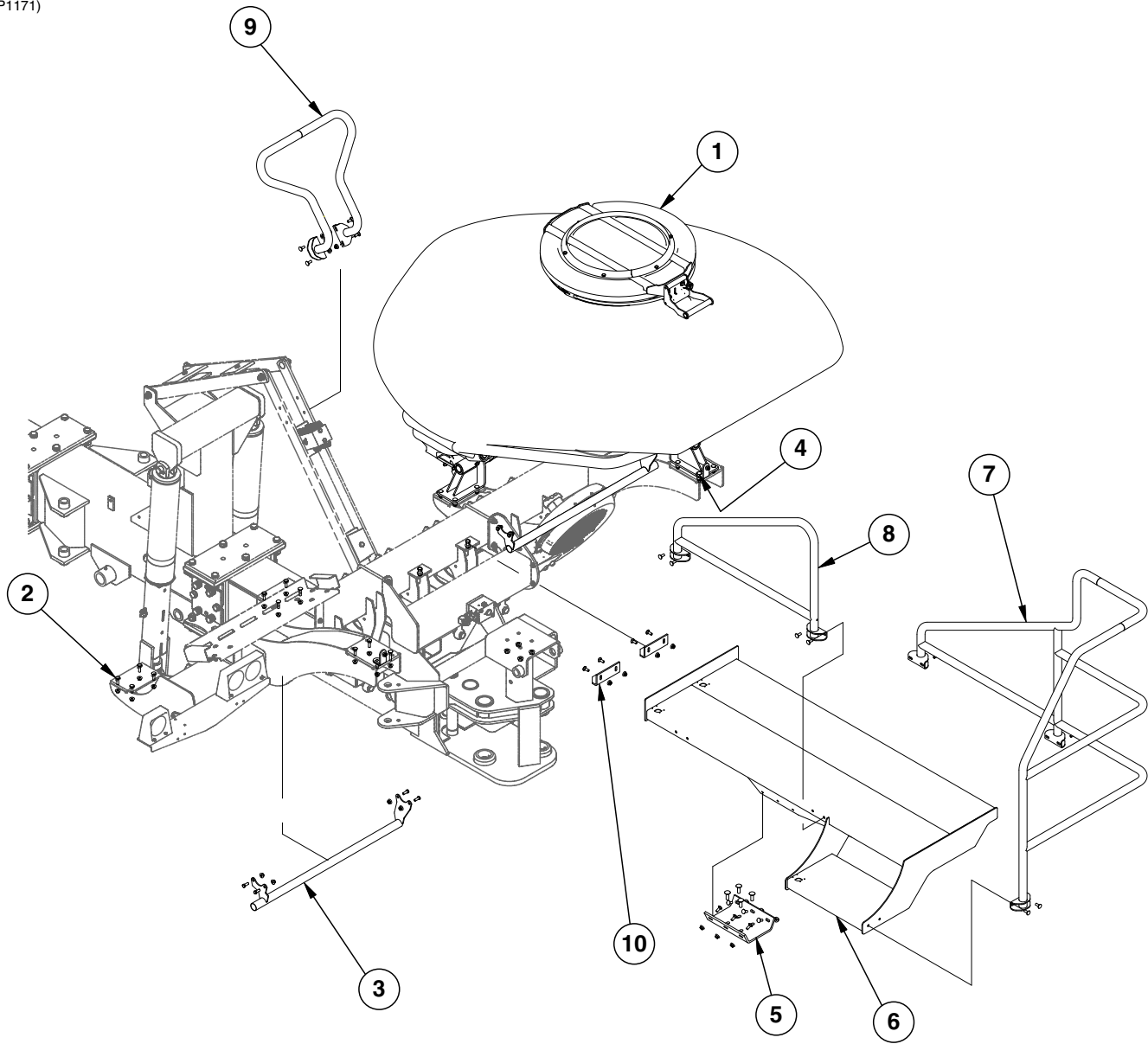

ITEM	PART NO.	QTY.	DESCRIPTION
1	---	-	<a href="#">See "ASD Tank Assembly" on page P71</a>
2	G10301	22	Carriage Bolt, 3/8"-16 x 1 1/2"
	G11091	22	Serrated Flange Nut, 3/8"-16
3	GA14110	2	Hose Hanger
	G10001	8	Hex Head Cap Screw, 3/8"-16 x 1"
	G11091	8	Serrated Flange Nut, 3/8"-16
4	G10306	2	Carriage Bolt, 3/8"-16 x 2"
	G11091	2	Serrated Flange Nut, 3/8"-16
5	GD19971	1	Rear Catwalk Mount Plate
	G10305	6	Carriage Bolt, 3/8"-16 x 1"
	G11091	6	Serrated Flange Nut, 3/8"-16
	G10636	4	Carriage Bolt, 1/2"-13 x 1 1/2"
	G10071	4	Serrated Flange Nut, 1/2"-13
6	GA14071	1	Catwalk
7	GA14080	1	R.H. Handrail
	G10305	6	Carriage Bolt, 3/8"-16 x 1"
	G11091	6	Serrated Flange Nut, 3/8"-16
8	GA14079	1	L.H. Handrail
	G10305	4	Carriage Bolt, 3/8"-16 x 1"
	G11091	4	Serrated Flange Nut, 3/8"-16
9	GA14097	1	Front Handrail
	G10305	4	Carriage Bolt, 3/8"-16 x 1"
	G11091	4	Serrated Flange Nut, 3/8"-16
10	GD19972	2	Front Catwalk Mount Plate
	G10037	2	Hex Head Cap Screw, 1/2"-13 X 1 1/4"
	G10071	2	Serrated Flange Nut, 1/2"-13
	G10305	4	Carriage Bolt, 3/8"-16 x 1"
	G11091	4	Serrated Flange Nut, 3/8"-16

(IP1180)

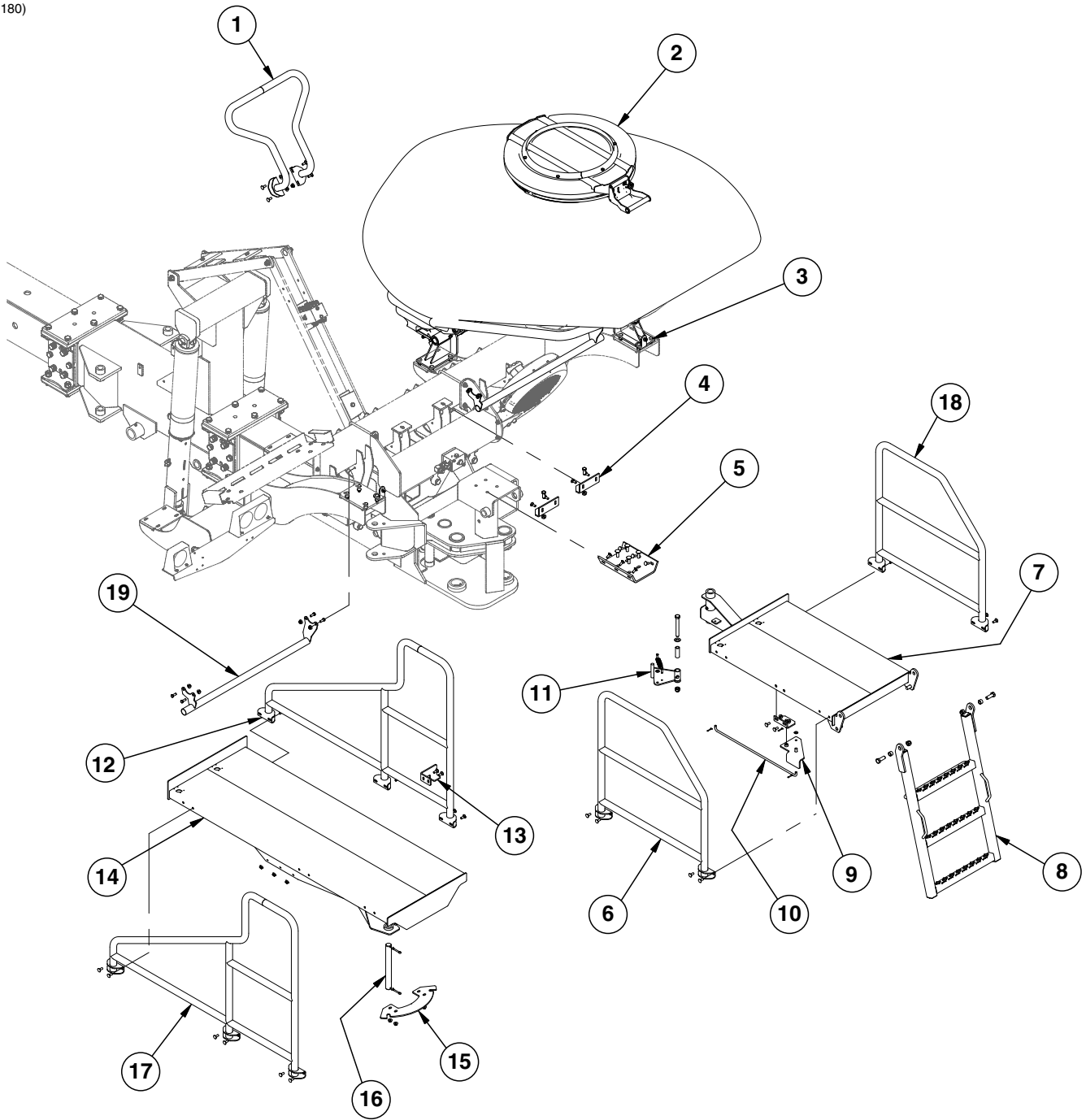

ITEM	PART NO.	QTY.	DESCRIPTION
1	GA14097	1	Front Handrail
	G10305	4	Carriage Bolt, 3/8"-16 x 1"
	G11091	4	Serrated Flange Nut, 3/8"-16
2	---	-	<a href="#">See "ASD Tank Assembly" on page P71</a>
3	G10301	22	Carriage Bolt, 3/8"-16 x 1 1/2"
	G11091	22	Serrated Flange Nut, 3/8"-16
4	GD19972	2	Front Catwalk Mount Plate
	G10037	2	Hex Head Cap Screw, 1/2"-13 X 1 1/4"
	G10071	2	Serrated Flange Nut, 1/2"-13
	G10305	4	Carriage Bolt, 3/8"-16 x 1"
	G11091	4	Serrated Flange Nut, 3/8"-16
5	GD19971	1	Rear Catwalk Mount Plate
	G10636	4	Carriage Bolt, 1/2"-13 x 1 1/2"
	G10071	4	Serrated Flange Nut, 1/2"-13
	G10305	6	Carriage Bolt, 3/8"-16 x 1"
	G11091	6	Serrated Flange Nut, 3/8"-16
6	GA14223	1	Rear L.H. Handrail
	G10305	4	Carriage Bolt, 3/8"-16 x 1"
	G11091	4	Serrated Flange Nut, 3/8"-16
7	GA14244	1	Rear Catwalk
8	GA14243	1	Ladder
	G10005	2	Hex Head Cap Screw, 5/8"-11 x 1 3/4"
	GB0218	2	Bushing, 2 1/32" I.D. x 7/8" O.D. x 1 9/32" Long
	G10107	2	Lock Nut, 5/8"-11
9	GA14241	1	Latch Handle
	G11387	2	Flat Washer, 3/8" SAE
	G10305	2	Carriage Bolt, 3/8"-16 x 1"
	G11091	2	Serrated Flange Nut, 3/8"-16
	G10451	1	Cotter Pin, 1/8" x 1"
	GA14240	1	Latch Mount
10	GD20252	1	Latch Stabilizer
	G10451	2	Cotter Pin, 1/8" x 1"
11	GA14242	1	Latch
	GD5857	1	Spring
	G10478	2	Clevis Pin, 5/16" x 1"
	G11391	2	Flat Washer, 5/8" SAE
	G10046	1	Hex Head Cap Screw, 5/8"-11 x 5"
	G10107	1	Lock Nut, 5/8"-11
	GD3180-32	1	Sleeve, 7/8" O.D. x 2 1/2"
12	GA14224	1	Front R.H. Handrail
	G10305	6	Carriage Bolt, 3/8"-16 x 1"
	G11091	6	Serrated Flange Nut, 3/8"-16
13	GD20356	1	Ladder Latch
	G10305	2	Carriage Bolt, 3/8"-16 x 1"
	G11091	2	Serrated Flange Nut, 3/8"-16
14	GA14246	1	Front Catwalk
15	GD20270	1	Latch Plate
	G10305	4	Carriage Bolt, 3/8"-16 x 1"
	G11091	4	Serrated Flange Nut, 3/8"-16
16	GD9542-05	1	Pin, 1 1/4" x 1 1 3/4"
	G10460	2	Cotter Pin, 1/4" x 2"
17	GA14225	1	Front L.H. Handrail
	G10305	6	Carriage Bolt, 3/8"-16 x 1"
	G11091	6	Serrated Flange Nut, 3/8"-16
18	GA14222	1	Rear R.H. Handrail
	G10305	4	Carriage Bolt, 3/8"-16 x 1"
	G11091	4	Serrated Flange Nut, 3/8"-16
19	GA14110	2	Hose Hanger
	G10001	8	Hex Head Cap Screw, 3/8"-16 x 1"
	G11091	8	Serrated Flange Nut, 3/8"-16

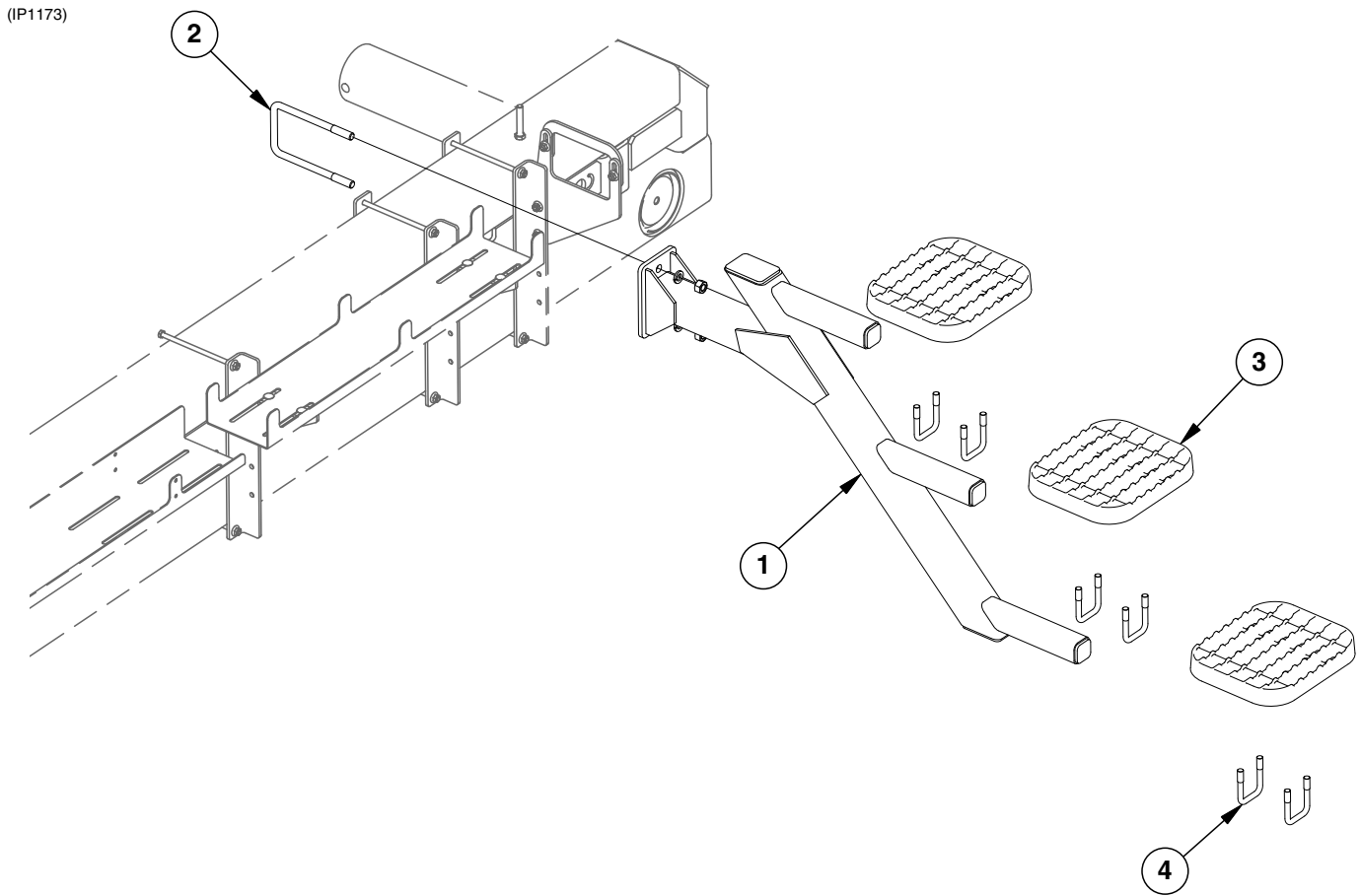

ITEM	PART NO.	QTY.	DESCRIPTION
1	GA14072	1	Step Bracket
2	GD20286	1	U-Bolt, 7" x 7" x 5/8"-11
	G10104	2	Hex Nut, 5/8"-11
	G10230	2	Lock Washer, 5/8"
3	GB0315	3	Step
4	GD2721	6	U-Bolt, 2" x 2" x 1/2"-13
	G10111	12	Lock Nut, 1/2"-13
	G11389	12	Flat Washer, 1/2" SAE

**This page left blank intentionally.**

(WGN47a/FF90a/A9646/A9662/FF93/FF141)

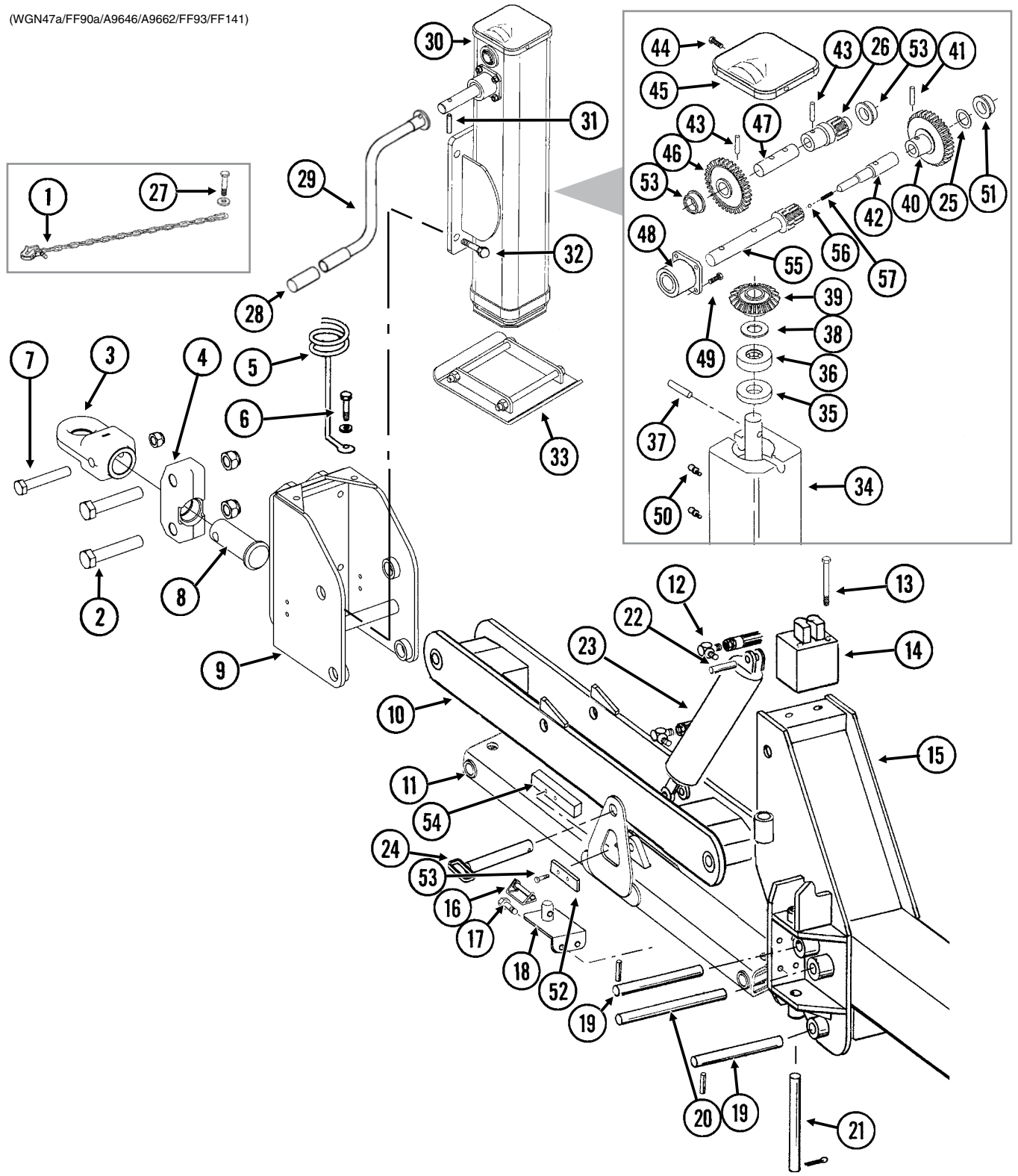

ITEM	PART NO.	QTY.	DESCRIPTION
1	GA9856	-	Safety Chain, 5/8"
	G1K413	-	Safety Chain Repair Kit, Includes: (1) Hook, (1) Flat Washer, (1) Latch Pin, (1) Safety Latch, (1) Spring, (1) Retaining Ring
2	G10042	2	Hex Head Cap Screw, 1 1/4"-7 x 6 1/2"
	G10157	2	Lock Nut, 1 1/4"-7
3	GB0361	1	Single Clevis, Swivel Hitch
4	GA9526	1	Swivel Block W/Grease Fitting
	G10643	-	Grease Fitting, 45°, 1/4"-28
5	GD9349	1	Hose Holder
6	G10006	1	Hex Head Cap Screw, 5/8"-11 x 2 1/4"
	G10230	1	Lock Washer, 5/8"
	G11391	1	Flat Washer, 5/8" SAE (If Applicable)
	G10104	1	Hex Nut, 5/8"-11
7	G10151	2	Hex Head Cap Screw, 1"-8 x 6"
	G10396	2	Lock Nut, 1"-8
8	GD13377	1	Spindle
9	GA9459	1	Hitch Cap
10	GA9894	1	Upper Hitch Link W/Grease Fittings
	G10640	-	Grease Fitting, 1/4"-28
11	GA10043	1	Lower Hitch Link W/Grease Fittings
	G10640	-	Grease Fitting, 1/4"-28
12	G6801-08	2	Elbow W/O-Ring, 90°, 3/4"-16 Male JIC To O-Ring
	GR1037	-	O-Ring
13	G10754	2	Hex Head Cap Screw, 5/16"-18 x 8"
	G10232	2	Lock Washer, 5/16"
	G10106	2	Hex Nut, 5/16"-18
14	---	-	<a href="#">See "Valve Block on Front Hitch" on page P143</a>
15	---	-	<a href="#">See "Front Hitch Assembly (Rear Section)" on page P89</a>
16	GD10705	1	Locking Clip Pin, 1/4" x 2 1/2"
17	G10019	2	Hex Head Cap Screw, 5/16"-18 x 1"
	G10232	2	Lock Washer, 5/16"
	G10106	2	Hex Nut, 5/16"-18
18	GA9654	1	Handle Mount
19	GD9464-01	4	Pin, 1 1/2" x 1 1/4"
	G10475	8	Spring Pin, 1/4" x 2 1/4"
20	GD0671	1	Pin, 1 1/4" x 10 3/4"
	G10460	2	Cotter Pin, 1/4" x 2"
21	GD4014	2	Pin, 1 1/4" x 12"
	G10460	4	Cotter Pin, 1/4" x 2"
22	GR0717	2	Pin W/Clip
	GR0193	-	Hair Pin Clip
23	---	-	<a href="#">See "Hitch Paralled Linkage Cylinder" on page P136</a>
24	GA6813	1	Parallel Linkage Lock Pin
	GD14217	1	Tab Lock Pin, 7/16" x 1 1/2"
25	G11032	1	Shim
26	GD13605	1	Output Spur Gear
27	G10494	1	Hex Head Cap Screw, 1 1/4"-7 x 3 1/2"
	GD21307	1	Washer, 3 3/4"
	G10157	1	Lock Nut, 1 1/4"-7
28	G11012	1	Cover
29	GA9655	1	Handle
30	GA9646	1	2-Speed Jack Assembly, Less Handle And Foot Assembly

ITEM	PART NO.	QTY.	DESCRIPTION
31	G11076	1	Spring Pin, M10 x 50 (Metric)
32	G10006	4	Hex Head Cap Screw, 5/8"-11 x 2 1/4"
	G10230	4	Lock Washer, 5/8"
	G10104	4	Hex Nut, 5/8"-11
33	GA9662	1	Jack Foot Assembly W/Hardware
	G11034	-	Hex Head Cap Screw, 1/2"-13 x 7"
	G10111	-	Lock Nut, 1/2"-13
34	GA9663	1	Lower Leg Assembly
35	GD13598	1	Collar
36	GA9665	1	Thrust Bearing
37	G10840	1	Dowel Pin, 3/8" x 1 3/4"
38	GD13600	1	Thrust Washer
39	GD13601	1	Bevel Gear
40	GD13602	1	Output Cluster Gear
41	G11030	1	Spring Pin, 3/8" x 1 3/4"
42	GD13603	1	Output Shaft
43	G11031	2	Spring Pin, 5/16" x 1 1/2"
44	G10960	2	Flanged Whiz-Lock Screw, 1/4"-20 x 5/8", No Serration
45	GD13607	1	Cover
46	GD13606	1	Input Spur Gear
47	GD13608	1	Output Shaft
48	GA14992	1	Shaft Housing Assembly
49	G10019	4	Hex Head Cap Screw, 5/16"-18 x 1"
	G10109	4	Lock Nut, 5/16"-18, Grade 8
50	G10641	2	Grease Fitting, 1/8" NPT
51	GD13604	3	Bushing
52	G10017	4	Hex Head Cap Screw, 1/2"-13 x 1 1/2"
	G10228	4	Lock Washer, 1/2"
53	GD15785	2	Mount, 1 1/2" x 5 1/2"
54	GD15787	2	Stop Block, 1 1/2" x 8"
55	GD13611	1	Input Shaft
56	GD13609	2	Detent Ball
57	GD13610	1	Detent Spring
A	GA9504	-	2-Speed Jack/Mount Sub-Assembly (Items 2-9, 30, 31 And 33)
B	G7786x	-	Safety Chain Package (Items: 1 and 27)

(FF62)

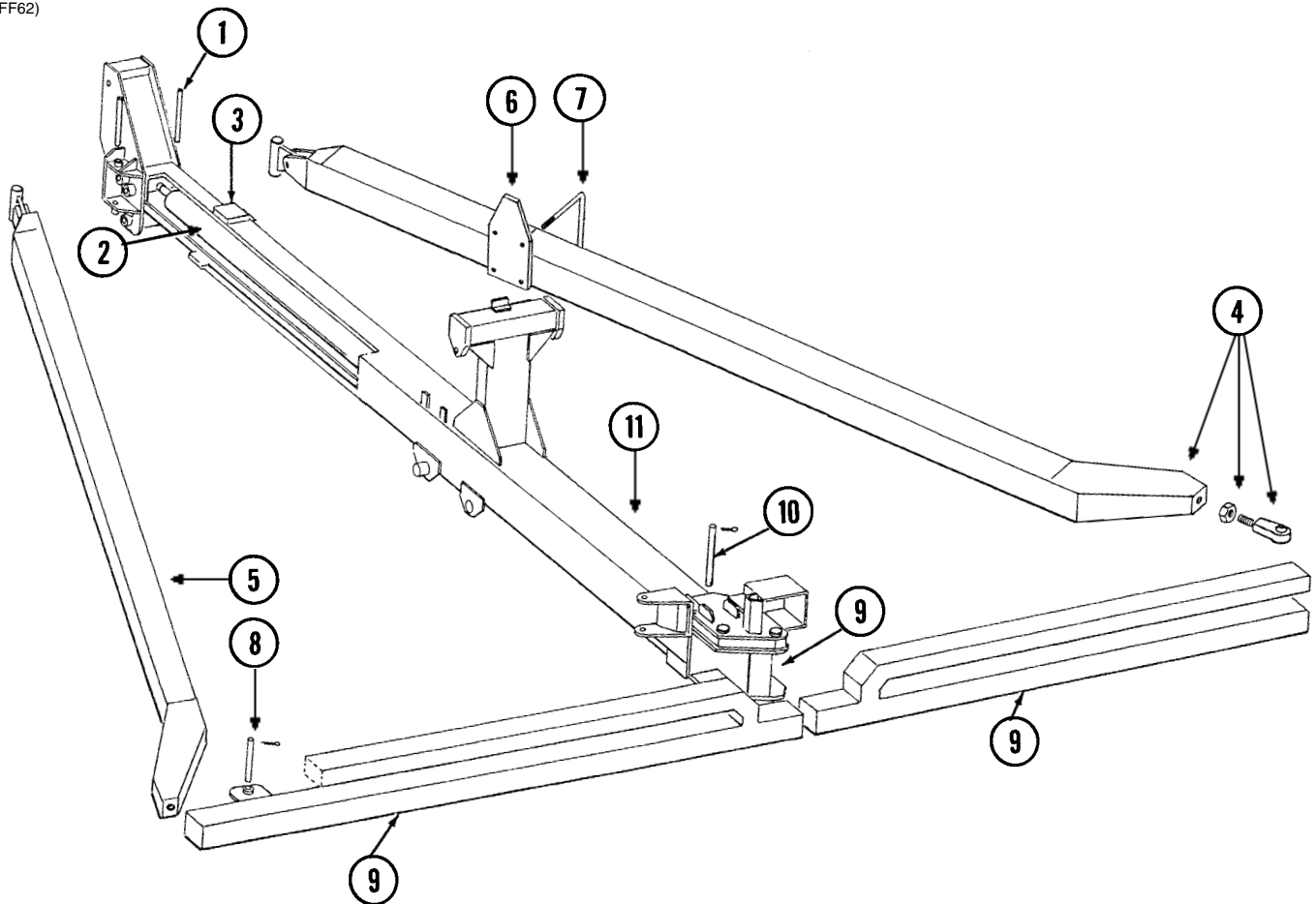

ITEM	PART NO.	QTY.	DESCRIPTION
1	---	-	<a href="#">See "Front Hitch Assembly/Safety Chain" on page P83</a>
2	---	-	<a href="#">See "Tongue Cylinder, 24 Row 20" on page P140</a>
3	---	-	<a href="#">See "Front Wear Pads" on page P90</a>
4	GA7476 GD10230 G10831 GA6660	1 - - -	R.H. Draft Link W/Split Locking Nut, Socket Head Screw And Joint, 24 Row 20" Split Locking Nut, 2"-12, Grade 2 Socket Head Screw, 1/4"-20 x 5/8" Joint
5	GA7475 GD10230 G10831 GA6660	1 - - -	L.H. Draft Link W/Split Locking Nut, Socket Head Screw And Joint, 24 Row 20" Split Locking Nut, 2"-12, Grade 2 Socket Head Screw, 1/4"-20 x 5/8" Joint
6	GA7490	2	Stop
7	GD1113 G10230 G10104	4 8 4	U-Bolt, 5" x 7" x 5/8"-11 Lock Washer, 5/8" Hex Nut, 5/8"-11
8	GD3421 G10460	2 4	Pin, 1 1/4" x 8 3/4" Cotter Pin, 1/4" x 2"
9	---	-	<a href="#">See "Hinge and Wing Assemblies" on page P98</a>
10	GD5506 G10460	1 2	Pin, 1 1/4" x 16" Cotter Pin, 1/4" x 2"
11	A7473	1	Rear Hitch (Non-Stock Item)

(TP1016)

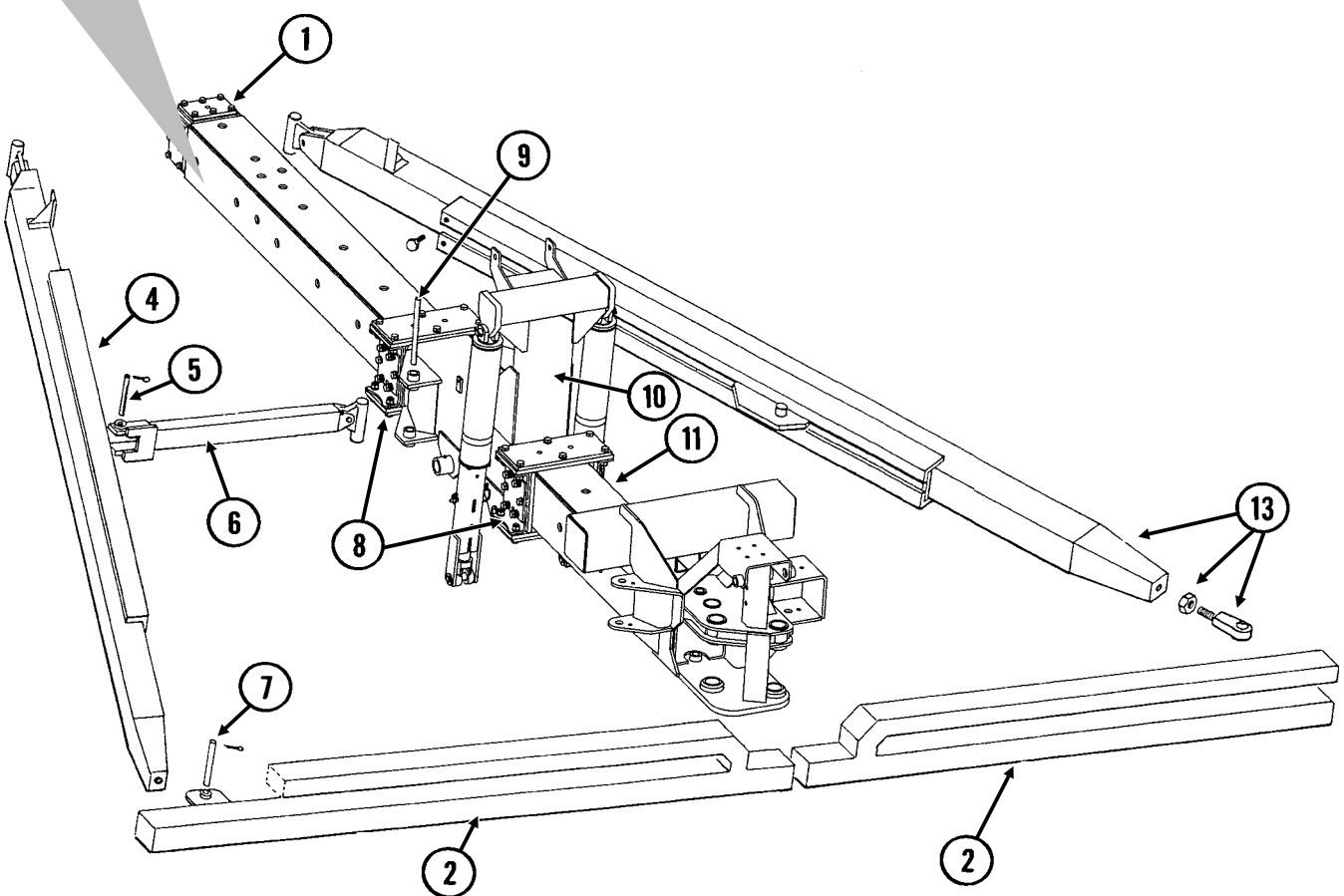
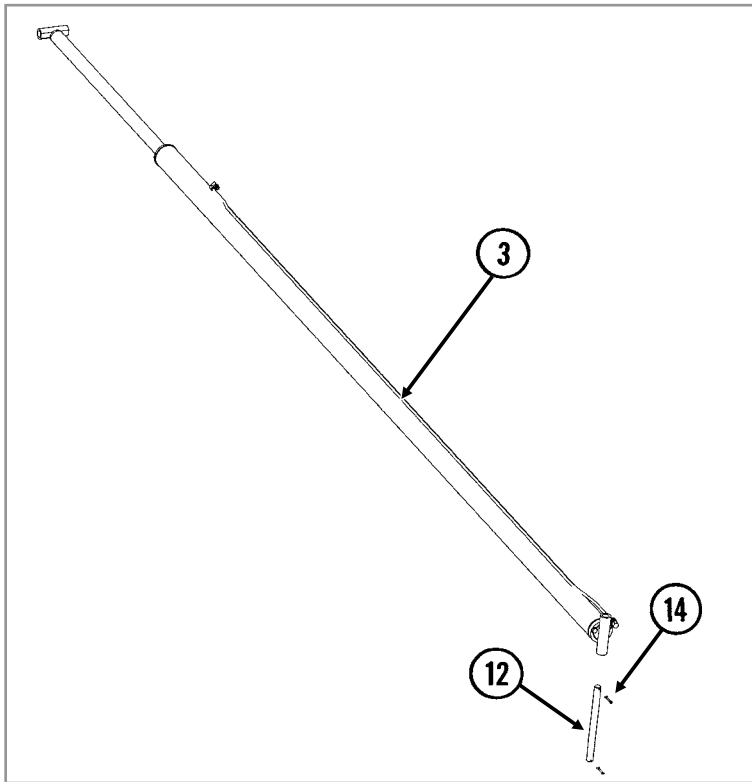

ITEM	PART NO.	QTY.	DESCRIPTION
1	---	-	<a href="#">See "Front Wear Pads" on page P90</a>
2	---	-	<a href="#">See "Hinge and Wing Assemblies" on page P97</a>
3	---	-	<a href="#">See "Tongue Cylinder, 24 Row 30" and 36 Row 20"" on page P141</a>
4	GA7453	1	L.H. Draft Link W/Split Locking Nut, Socket Head Screw And Joint
	GD10230	-	Split Locking Nut, 2"-12, Grade 2
	G10831	-	Hex Socket Head Screw, 1/4"-20 x 5/8"
	GA6660	-	Joint
5	GD9542-03	2	Pin, 1 1/4" x 6 1/8"
	G10460	4	Cotter Pin, 1/4" x 2"
6	GA6654	2	Axle Link
7	GD3421	2	Pin, 1 1/4" x 8 3/4"
	G10460	4	Cotter Pin, 1/4" x 2"
8	---	-	<a href="#">See "Tower Assembly, 24 Row 30" and 36 Row 20"" on page P93</a>
9	GD9542-04	2	Pin, 1 1/4" x 15"
	G10460	4	Cotter Pin, 1/4" x 2"
10	---	-	<a href="#">See "Tower Assembly, 24 Row 30" and 36 Row 20"" on page P93</a>
11	A14702	1	Rear Hitch <b>(Non-Stock Item)</b>
12	GD5506	1	Pin, 1 1/4" x 16"
	G10460	2	Cotter Pin, 1/4" x 2"
13	GA7454	1	R.H. Draft Link W/Split Locking Nut, Socket Head Screw And Joint
	GD10230	-	Split Locking Nut, 2"-12, Grade 2
	G10831	-	Hex Socket Head Screw, 1/4"-20 x 5/8"
	GA6660	-	Joint
14	G10460	2	Cotter Pin, 1/4" x 2"

(IP1306)

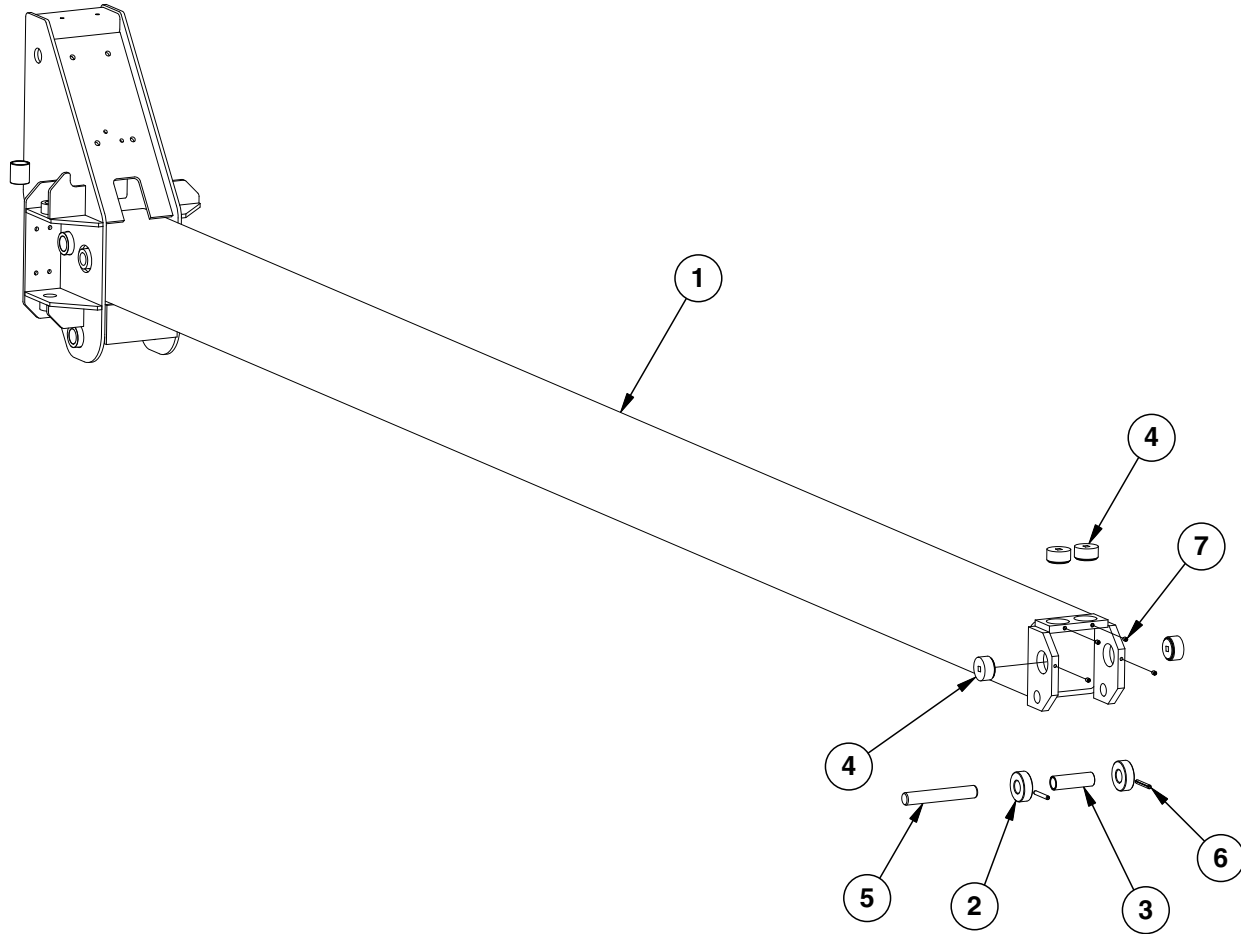

ITEM	PART NO.	QTY.	DESCRIPTION
1	A14700	1	Front Hitch, 199 5/8" <b>(Non-Stock Item)</b> , 24 Row 30"
	A8973	1	Front Hitch, 166 5/8" <b>(Non-Stock Item)</b> , 24 Row 20"
2	GD9366	2	Roller
3	GD9367	1	Sleeve
4	GD21000	4	Bronze Adjusting Plug
5	GD9362	1	Mounting Pin
6	G10769	2	Spring Pin, 3/8" x 2 3/4"
7	G10760	4	Hex Socket Set Screw, 3/8"-16 x 1/2"

(IP1305)

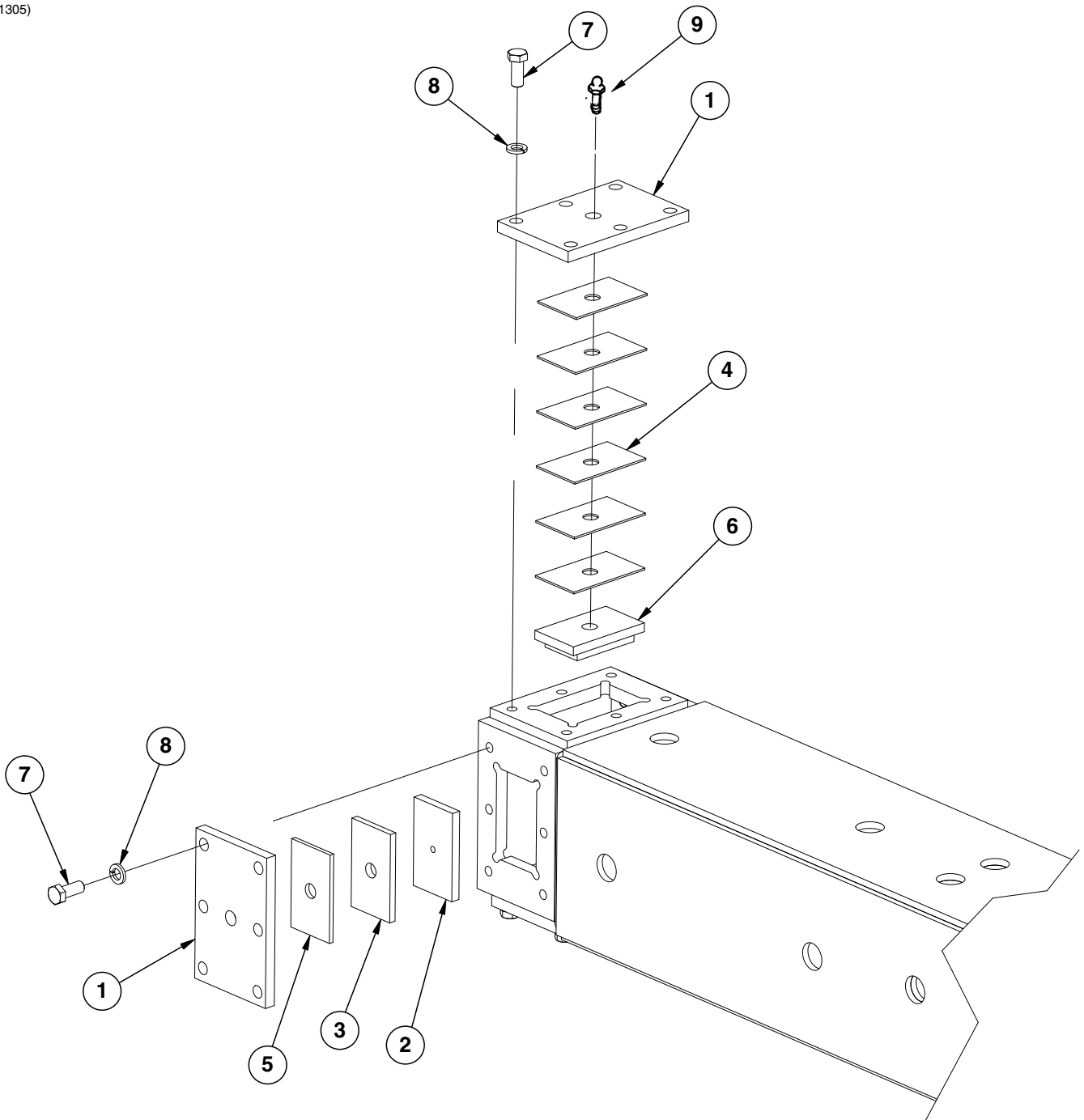

ITEM	PART NO.	QTY.	DESCRIPTION
1	GD9467	4	Cap
2	GD9468	2	Bearing Pad
3	GD9465	2	Shim, 3/8"
4	GD9498	12	Shim, 12 Gauge
5	GD10981	2	Shim, 1/4" (As Required)
6	GA6655	2	Retainer Pad
7	G10007	24	Hex Head Cap Screw, 5/8"-11 x 1 1/2"
8	G10230	24	Lock Washer, 5/8"
9	G10763	4	Grease Fitting, Extended, 1/8"-27

**This page left blank intentionally.**

(FF63b)

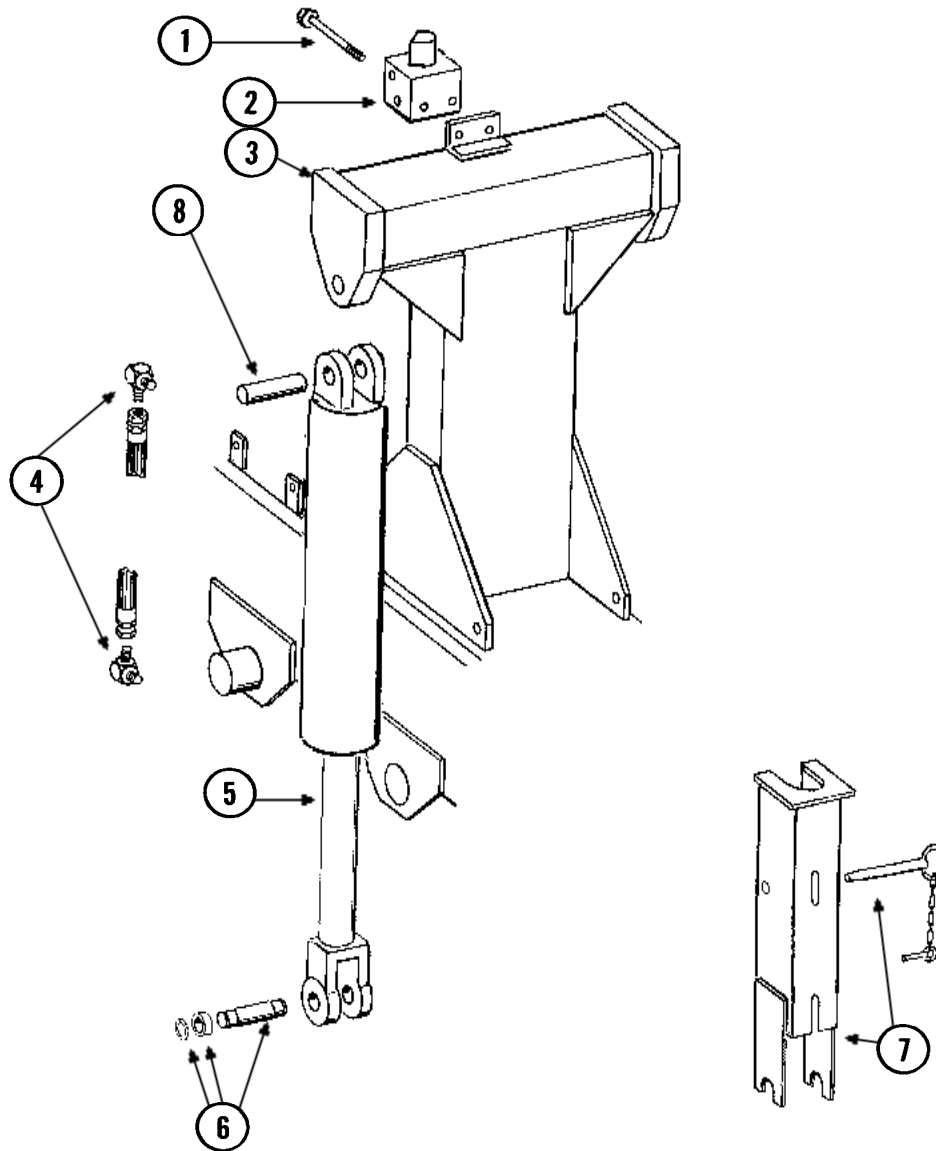

ITEM	PART NO.	QTY.	DESCRIPTION
1	G10326	2	Hex Head Cap Screw, 3/8"-16 x 3 3/4"
	G10229	2	Lock Washer, 3/8"
	G10101	2	Hex Nut, 3/8"-16
2	---	-	<a href="#">See "Valve Block on Tower Assembly" on page P144</a>
3	---	-	<a href="#">See "Hitch and Linkage Assembly, 24 Row 20" on page P86</a>
4	G6801-08	4	Elbow W/O-Ring, 90°, 3/4"-16 Male JIC To O-Ring
	GR1037	-	O-Ring
5	---	-	<a href="#">See "Slave Cylinders" on page P135</a>
6	GD12545	2	Pin, 1 1/4" x 5 1/2"
	GD12535	4	Special Bushing, 2" O.D. x 1" I.D. x 3/4" Long
	G10982	4	HD External Retaining Ring, 1"
7	GA8971	1	Cylinder Lockup Bracket W/Pin Assembly
	GA8312	-	Pin W/Lynch Pin, 5 1/2"
8	GD12585	2	Pin, 1 1/4" x 4 1/2"
	G10460	4	Cotter Pin, 1/4" x 2"

(IP1158)

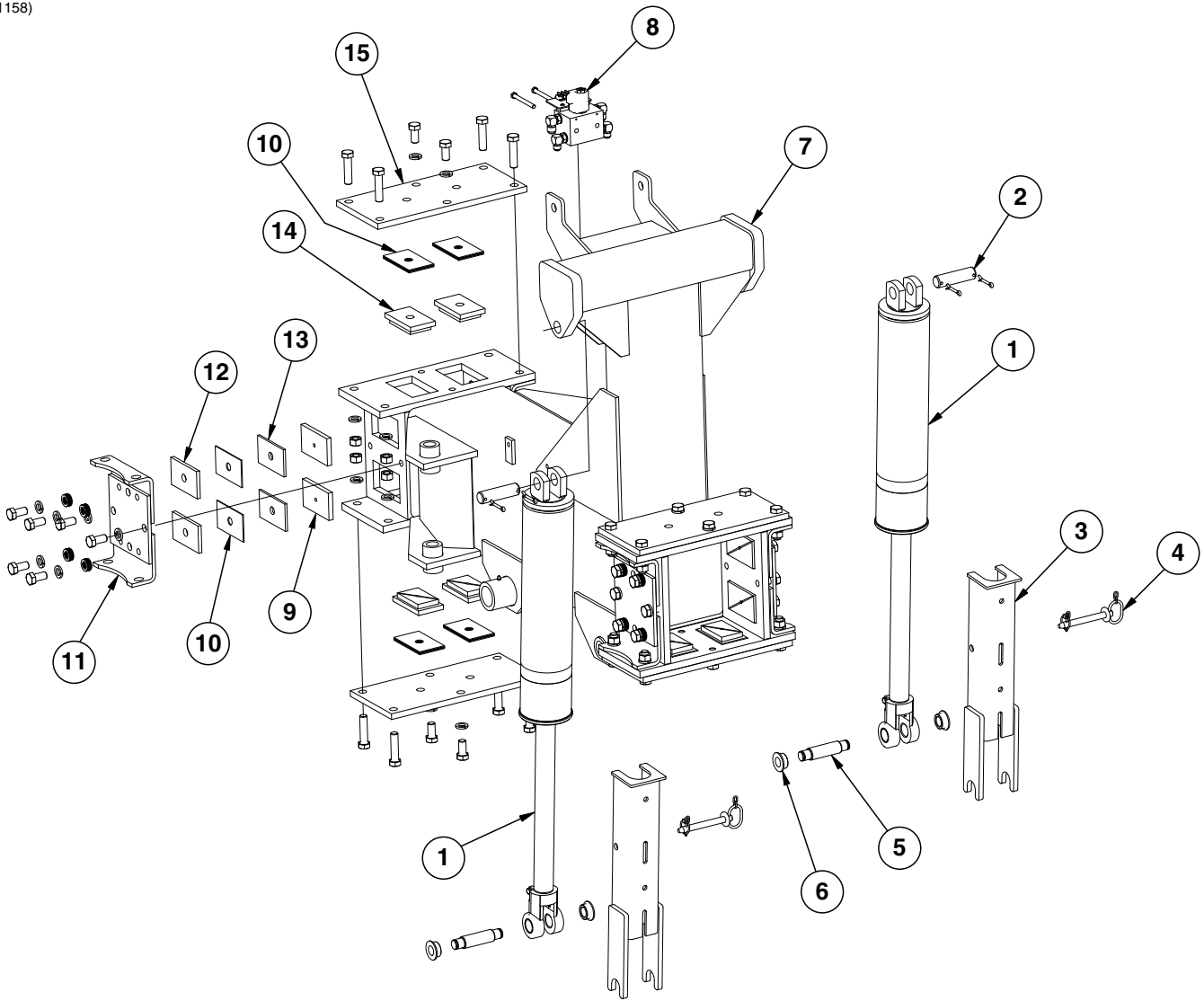

ITEM	PART NO.	QTY.	DESCRIPTION
1	---	2	<a href="#">See "Slave Cylinders" on page P135</a>
2	GD12585	2	Pin, 1¼" x 4½"
	G10460	4	Cotter Pin, ¼" x 2"
	GA8971	2	Cylinder Lockup Bracket W/Pin Assembly
3	GA8963	1	Cylinder Lockup
4	GA8312	1	Pin W/Lynch Pin, 5½"
5	GD12545	2	Pin, 1¼" x 5½"
	G10982	4	HD External Retaining Ring, 1"
6	GD12535	4	Special Bushing, 2" O.D. x 1" I.D. x ¾" Long
7	GA14022	1	Axle Mount
8	---	1	<a href="#">See "Valve Block on Tower Assembly" on page P144</a>
	G10324	2	Hex Head Cap Screw, ⅜"-16 x 3¾"
9	GD9468	8	Bearing Pad
10	GD9498	32	Shim, 12 Gauge
11	GA12595	4	Retainer
	G10231	24	Lock Washer, ¾"
	G10215	112	Machine Bushing, ¾", 14 Gauge
	G10025	24	Hex Head Cap Screw, ¾"-10 x 1½"
12	GD9465	8	Shim, ⅝"
13	GD10981	8	Shim, ¼"
14	GA6655	8	Retainer Pad
15	GD18328	4	Retainer, 8" x 18¾"
	G10763	16	Grease Fitting, Extended, ⅛"-27
	G10105	16	Hex Nut, ¾"-10
	G10028	16	Hex Head Cap Screw, ¾"-10 x 3"
	G10231	24	Lock Washer, ¾"
	G10025	8	Hex Head Cap Screw, ¾"-10 x 1½"

PHA031(FF8e)

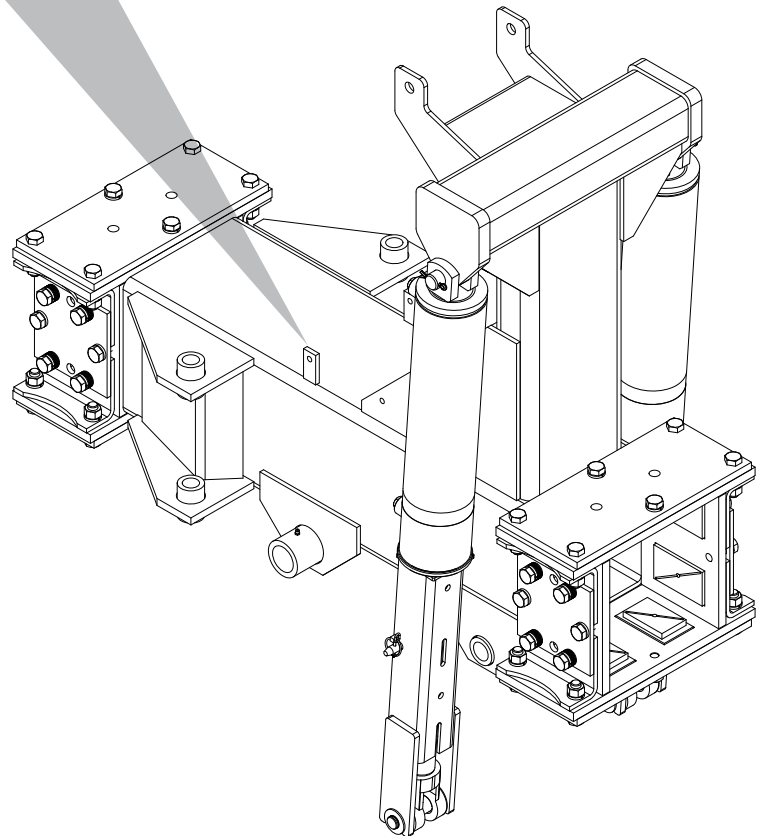
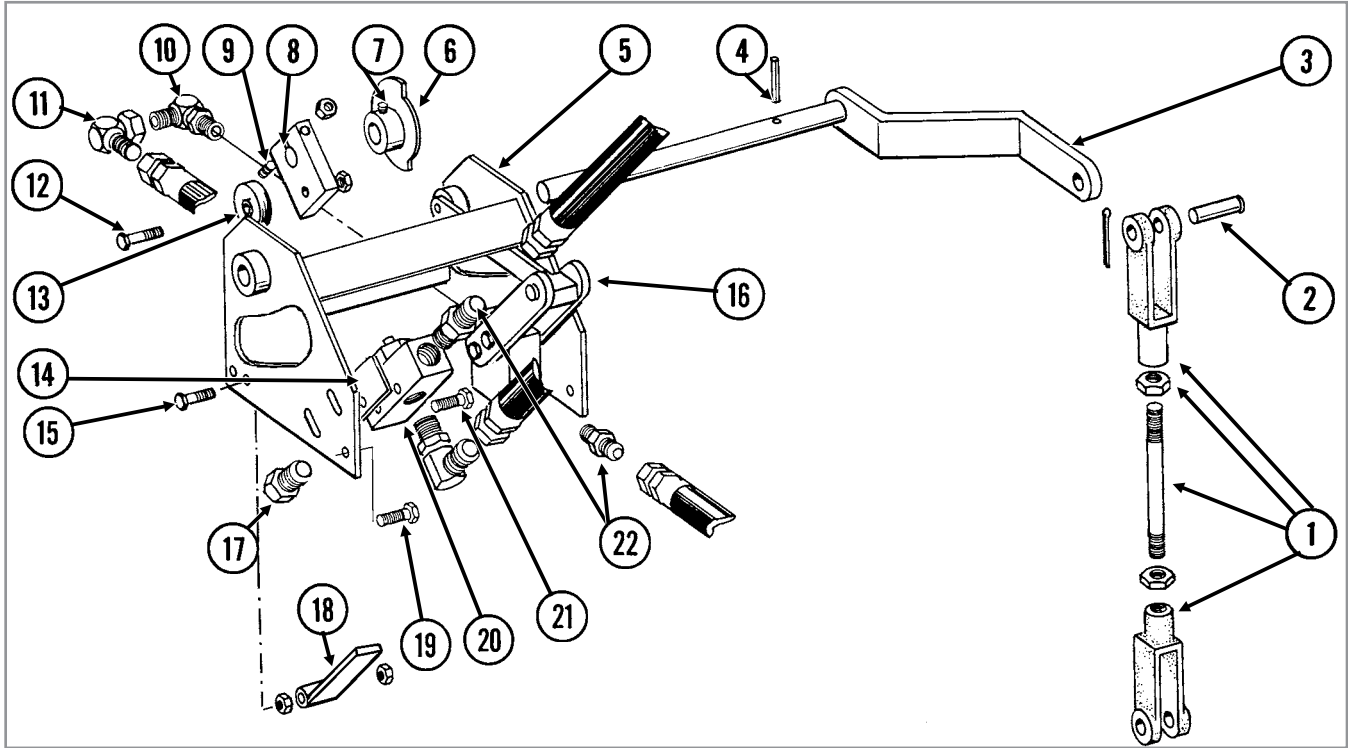

ITEM	PART NO.	QTY.	DESCRIPTION
1	GA6646	1	Rod Assembly
	GD8218	-	Yoke
	GD9499	-	Stud
	G10104	-	Hex Nut, 5/8"-11
2	G10284	2	Clevis Pin, 1/2" x 1 1/2"
	G10451	2	Cotter Pin, 1/8" x 1"
3	GA6685	1	Cam Activator
4	G10606	1	Spring Pin, 1/4" x 2"
5	GA6687	1	Housing
6	GA6686	1	Cam
7	G10120	2	Hex Socket Set Screw, 3/8"-16 x 1/2"
8	GD9511	1	Detent Arm
9	G10048	1	Hex Head Cap Screw, 3/8"-16 x 2"
	G10108	1	Lock Nut, 3/8"-16
10	G6801-10-08	1	Elbow W/O-Ring, 90°, 7/8"-14 Male JIC To 3/4"-16 O-Ring
	GR1037	-	O-Ring
11	G6500-10	1	Swivel Elbow, 90°, 7/8"-14 Male JIC To Female
12	G10009	1	Hex Head Cap Screw, 5/8"-11 x 2 1/2"
	G10107	1	Lock Nut, 5/8"-11
13	GA2014	1	Bearing
14	GD10714	-	Spacer
15	G10048	1	Hex Head Cap Screw, 3/8"-16 x 2"
	G10101	2	Hex Nut, 3/8"-16
16	---	-	<a href="#">See "Detent Lever Valve" on page P150</a>
17	G6408-08	1	Plug W/O-Ring, 3/4"-16 O-Ring
	GR1037	-	O-Ring
18	GA7153	1	Stroke Limiter Arm (If Applicable)
19	G10004	4	Hex Head Cap Screw, 3/8"-16 x 1 1/4"
	G10229	4	Lock Washer, 3/8"
	G10101	4	Hex Nut, 3/8"-16
20	---	-	<a href="#">See "Stroke Limiter Valve" on page P151</a>
21	G10069	2	Hex Head Cap Screw, 5/16"-18 x 2 1/4"
	G10109	2	Lock Nut, 5/16"-18
	G11386	2	Flat Washer, 5/16" SAE
22	G6400-10-08	1	Connector W/O-Ring, 7/8"-14 Male JIC To 3/4"-16 O-Ring
	GR1037	-	O-Ring

PFA062/PFA052(FF9c)

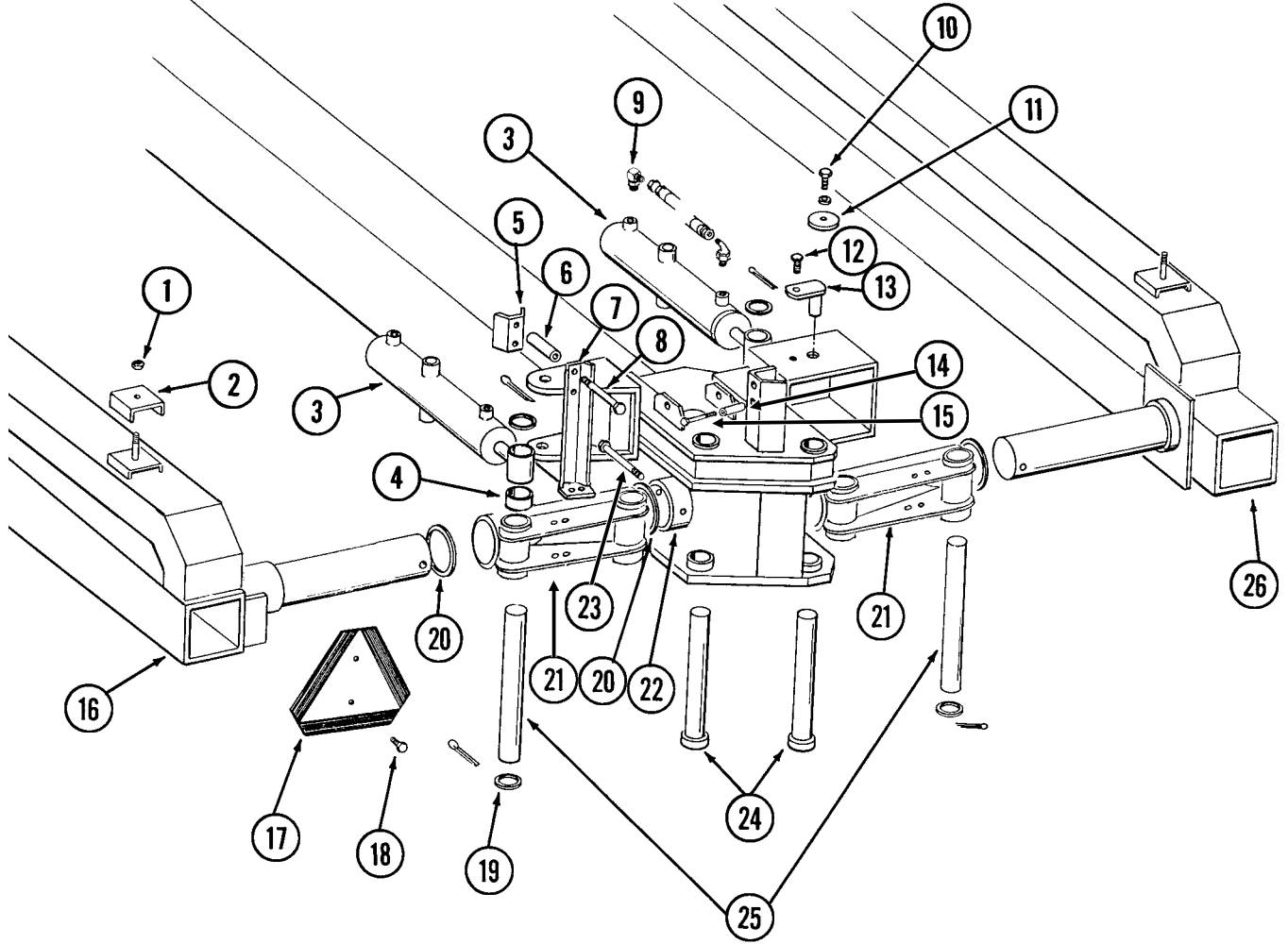

ITEM	PART NO.	QTY.	DESCRIPTION
1	G10111	-	Lock Nut, 1/2"-13
2	GD0740	18	Hose Clamp, 3/4" x 4" x 3 1/2"
	GD0776	2	Hose Clamp, 3/4" x 2" x 2 1/2"
3	---	-	<a href="#">See "Helper Cylinder, All Sizes" on page P139</a>
4	GD9727	2	Spacer
5	GD9361	2	Hose Guide
6	GD3180-13	4	Sleeve, 5/8" I.D. x 7/8" O.D. x 4" Long
7	GA6640	1	Bracket
8	G10011	2	Hex Head Cap Screw, 5/8"-11 x 5 1/2"
	G10230	2	Lock Washer, 5/8"
	G10104	2	Hex Nut, 5/8"-11
9	G6801-06-08	4	Elbow W/O-Ring, 90°, 9/16"-18 Male JIC To 3/4"-16 O-Ring
	GR1037	-	O-Ring
10	G10026	2	Hex Head Cap Screw, 3/4"-10 x 2"
	G10231	2	Lock Washer, 3/4"
11	GD9516	2	Pivot Washer
12	G10017	4	Hex Head Cap Screw, 1/2"-13 x 1 1/2"
	G10228	4	Lock Washer, 1/2"
	G10102	4	Hex Nut, 1/2"-13
13	GA6761	4	Pin
14	GD3180-06	2	Sleeve, 5/8" I.D. x 7/8" O.D. x 1 3/4" Long
15	G10013	2	Hex Head Cap Screw, 5/8"-11 x 3 1/2"
	G10036	-	Hex Head Cap Screw, 5/8"-11 x 4"
	G10230	2	Lock Washer, 5/8"
	G10104	2	Hex Nut, 5/8"-11
16	GA9031	1	<a href="#">See "Wing Frame, 24 Row 30" on page P99</a>
	G7459	-	<a href="#">See "Wing Frame, 36 Row 20" on page P101</a> L.H. Wing, 246 3/8", 24 Row 20"
17	GD2199	1	SMV Sign
18	G10022	2	Hex Head Cap Screw, 1/4"-20 x 1/2"
	G10227	2	Lock Washer, 1/4"
	G10103	2	Hex Nut, 1/4"-20
19	G10360	4	Machine Bushing, 2 1/2", 10 Gauge
20	GD9462	6	Washer
21	GA8137	-	Knuckle Less Grease Fittings
	G10640	3	Grease Fitting, 1/4"-28
22	GD9463	2	Washer
23	G10057	2	Hex Head Cap Screw, 3/4"-10 x 7"
	G10231	2	Lock Washer, 3/4"
	G10105	2	Hex Nut, 3/4"-10
24	GA8994	-	Vertical Pin
	G10360	-	Machine Bushing, 2 1/2", 10 Gauge (As Required)
	G10359	-	Machine Bushing, 2 1/2", 18 Gauge (As Required)
	GD12692	-	Pin, 3/8" x 3 1/2"
25	GD9726	2	Pin, 2 1/2" x 13 1/8"
	G10461	4	Cotter Pin, 3/8" x 3"
26	GA9032	1	<a href="#">See "Wing Frame, 24 Row 30" on page P99</a>
	GA7462	-	<a href="#">See "Wing Frame, 36 Row 20" on page P101</a> R.H. Wing, 243 3/8", 24 Row 20"

(IP1165)

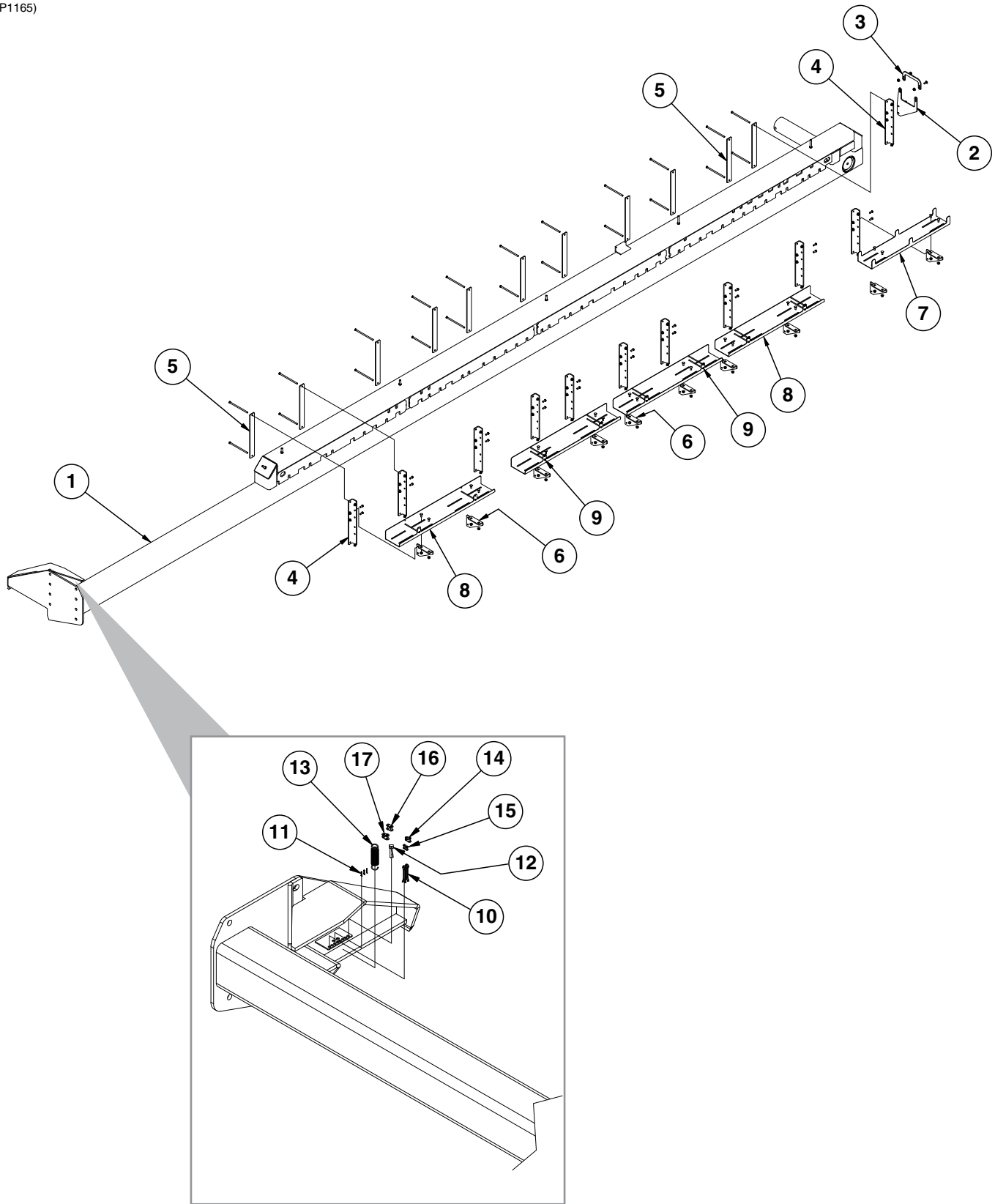

ITEM	PART NO.	QTY.	DESCRIPTION
1	GA9031	1	L.H. Wing (Shown)
	GA9032	1	R.H. Wing
*2	GD20113	1	Center Seed Hose Bracket
	G10001	2	Hex Head Cap Screw, 3/8"-16 x 1"
	G11091	2	Serrated Flange Nut, 3/8"-16
*3	GD20115	1	Center Bracket
	G10305	2	Carriage Bolt, 3/8"-16 x 1"
	G11091	2	Serrated Flange Nut, 3/8"-16
*4	GD20062	11	Manifold Support
*5	GD20091	11	Front Mount Plate
	G10686	22	Hex Head Cap Screw, 3/8"-16 x 8"
	G11091	22	Serrated Flange Nut, 3/8"-16
*6	GD20119	10	Hose Tray Support Bracket
	G10001	20	Hex Head Cap Screw, 3/8"-16 x 1"
	G11091	20	Serrated Flange Nut, 3/8"-16
*7	GD20063	1	Front Hose Tray
	G10305	4	Carriage Bolt, 3/8"-16 x 1"
	G11091	4	Serrated Flange Nut, 3/8"-16
*8	GD20174	4	End Hose Tray
	G10305	16	Carriage Bolt, 3/8"-16 x 1"
	G11091	16	Serrated Flange Nut, 3/8"-16
*9	GD20069	14	Pin, 1/4" x 7"
	G10669	28	Hair Pin Clip, No. 22
10	G10460	2	Cotter Pin, 1/4" x 2" (Toolbox)
	G10670	3	Hair Pin Clip, No. 3 (Toolbox)
11	G10455	3	Cotter Pin, 1/16" x 1/2" (Toolbox)
	G10478	2	Clevis Pin, 5/16" x 1" (Toolbox)
12	GD2558	1	Lynch Pin, 1/4" (Toolbox)
	G10821	3	Clevis Pin, 3/16" x 2" (Toolbox)
13	GD5857	1	Spring (Toolbox)
14	GR0201	1	Offset Link, No. 41 (Toolbox)
15	GR0196	1	Connector Link, No. 41 (Toolbox)
16	GR0912	1	Connector Link, No. 40 (Toolbox)
17	GR0911	1	Offset Link, No. 40 (Toolbox)

\*Items 2-9 are for ASD models only.

(IP1184)

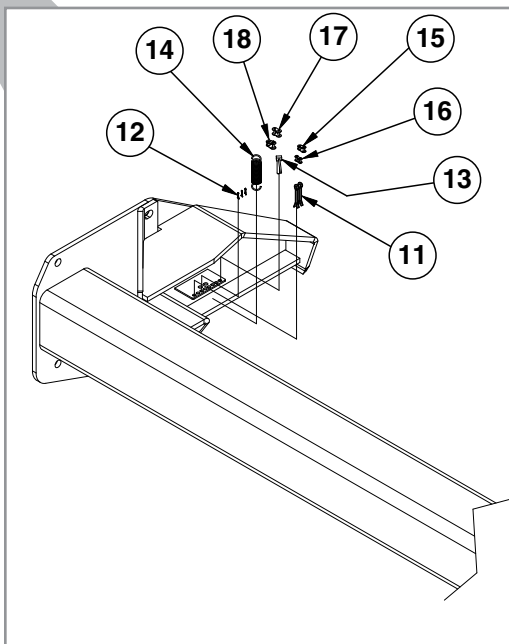
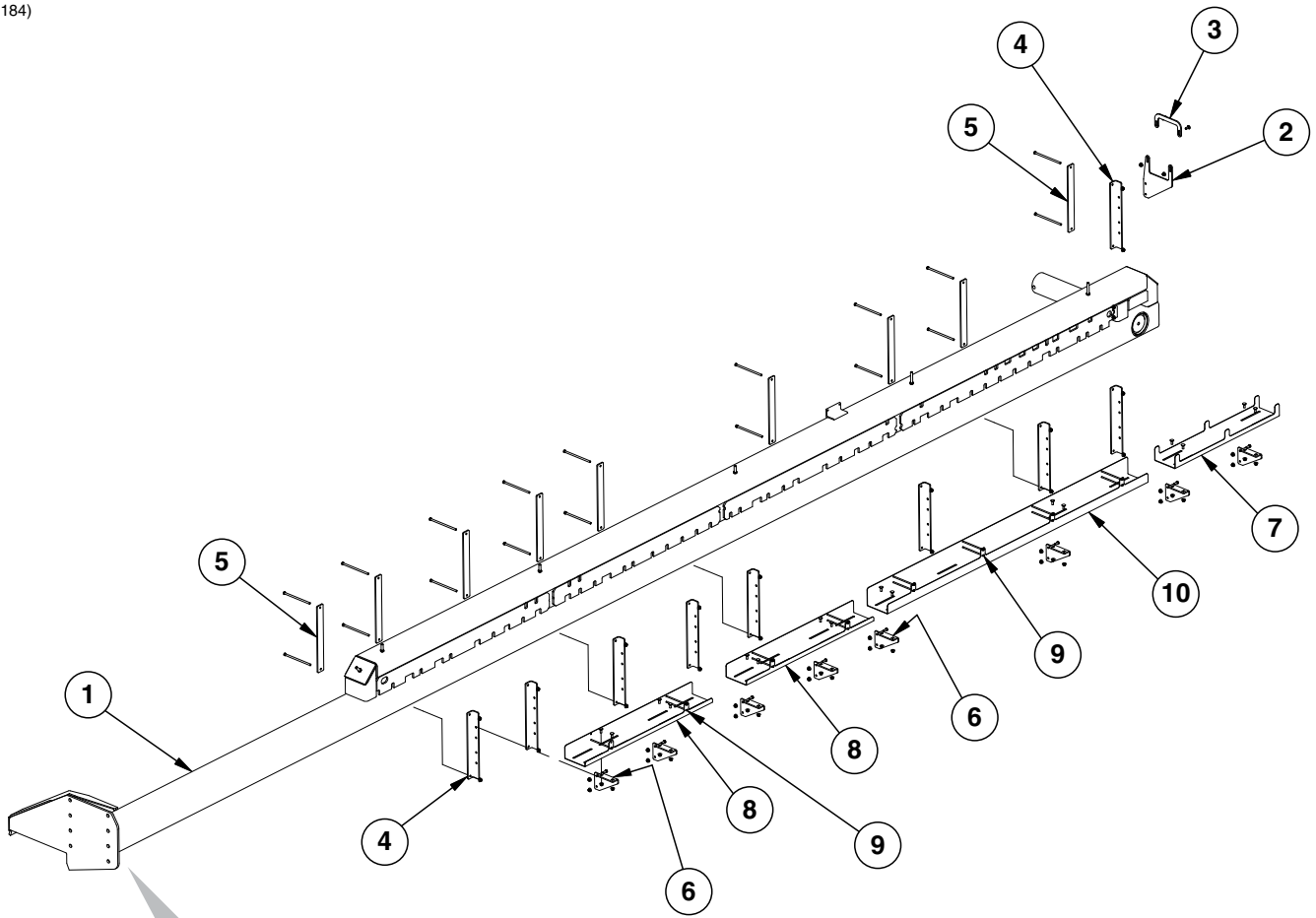

ITEM	PART NO.	QTY.	DESCRIPTION
1	GA9031	1	L.H. Wing (Shown)
	GA9032	1	R.H. Wing
*2	GD20113	1	Center Seed Hose Bracket
	G10001	2	Hex Head Cap Screw, $\frac{3}{8}$ "-16 x 1"
	G11091	2	Serrated Flange Nut, $\frac{3}{8}$ "-16
*3	GD20115	1	Center Bracket
	G10305	2	Carriage Bolt, $\frac{3}{8}$ "-16 x 1"
	G11091	2	Serrated Flange Nut, $\frac{3}{8}$ "-16
*4	GD20062	9	Manifold Support
*5	GD20091	9	Front Mount Plate
	G10686	18	Hex Head Cap Screw, $\frac{3}{8}$ "-16 x 8"
	G11091	18	Serrated Flange Nut, $\frac{3}{8}$ "-16
*6	GD20119	8	Hose Tray Support Bracket
	G10001	16	Hex Head Cap Screw, $\frac{3}{8}$ "-16 x 1"
	G11091	16	Serrated Flange Nut, $\frac{3}{8}$ "-16
*7	GD20063	1	Front Hose Tray
	G10305	4	Carriage Bolt, $\frac{3}{8}$ "-16 x 1"
	G11091	4	Serrated Flange Nut, $\frac{3}{8}$ "-16
*8	GD20174	2	End Hose Tray
	G10305	8	Carriage Bolt, $\frac{3}{8}$ "-16 x 1"
	G11091	8	Serrated Flange Nut, $\frac{3}{8}$ "-16
*9	GD20069	15	Pin, $\frac{1}{4}$ " x 7"
	G10669	30	Hair Pin Clip, No. 22
10	GD20173	1	Middle Hose Tray
	G10305	4	Carriage Bolt, $\frac{3}{8}$ "-16 x 1"
	G11091	4	Serrated Flange Nut, $\frac{3}{8}$ "-16
11	G10460	2	Cotter Pin, $\frac{1}{4}$ " x 2" (Toolbox)
	G10670	3	Hair Pin Clip, No. 3 (Toolbox)
12	G10455	3	Cotter Pin, $\frac{1}{16}$ " x $\frac{1}{2}$ " (Toolbox)
	G10478	2	Clevis Pin, $\frac{5}{16}$ " x 1" (Toolbox)
13	GD2558	1	Lynch Pin, $\frac{1}{4}$ " (Toolbox)
	G10821	3	Clevis Pin, $\frac{3}{16}$ " x 2" (Toolbox)
14	GD5857	1	Spring (Toolbox)
15	GR0201	1	Offset Link, No. 41 (Toolbox)
16	GR0196	1	Connector Link, No. 41 (Toolbox)
17	GR0912	1	Connector Link, No. 40 (Toolbox)
18	GR0911	1	Offset Link, No. 40 (Toolbox)

\*Items 2-9 are for ASD models only.

(IP1155)

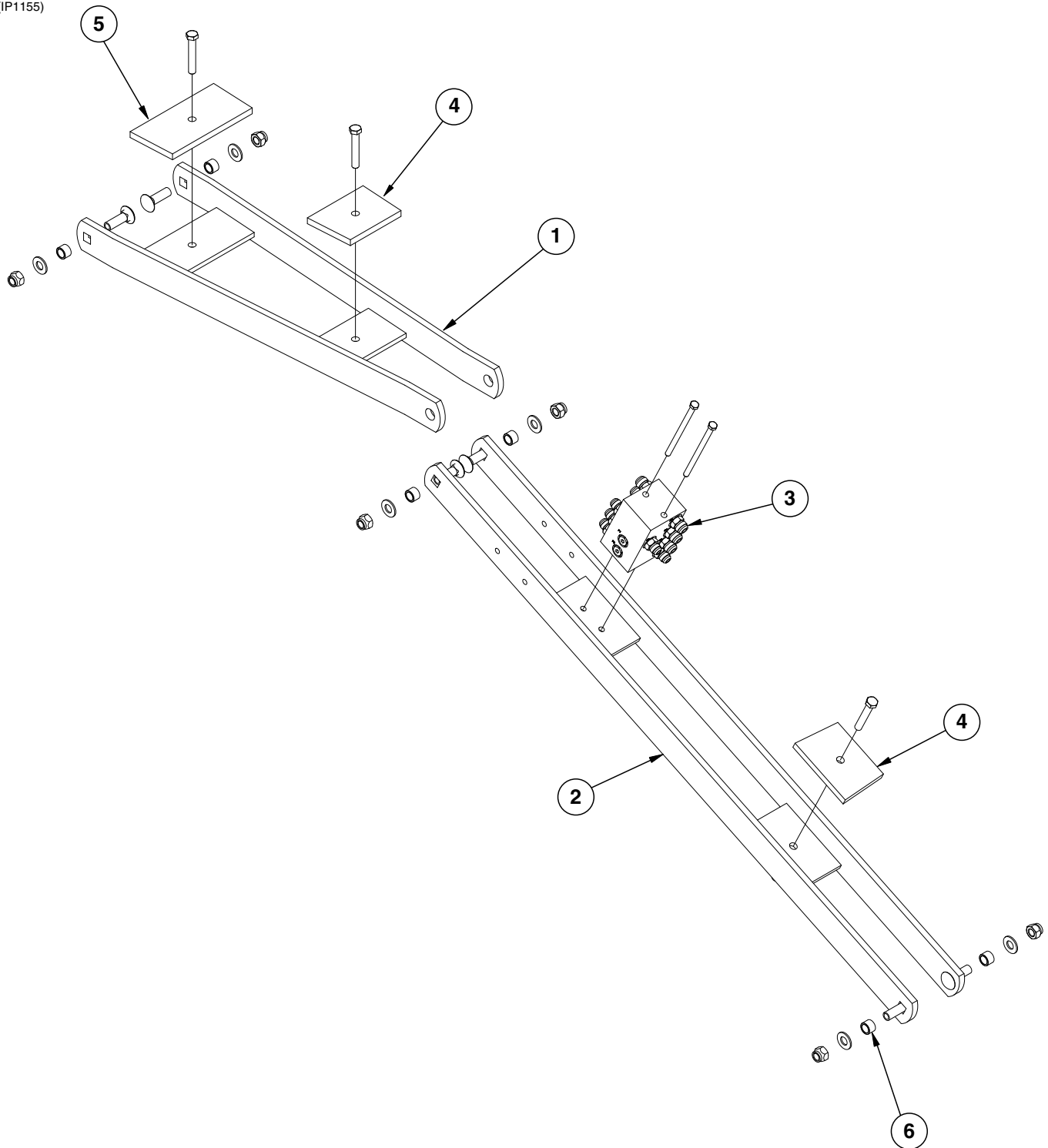

ITEM	PART NO.	QTY.	DESCRIPTION
1	GA14026	1	Front Hose Take-Up
2	GA14027	1	Rear Hose Take-Up
3	---	1	<a href="#">See "Junction Block on Hose Take-Up" on page P149</a>
	G10756	2	Hex Head Cap Screw, 3/8"-16 x 6"
	G11091	2	Serrated Flange Nut, 3/8"-16
4	GD11894	2	Spacer, 4" x 5 1/2"
	G10038	2	Hex Head Cap Screw, 1/2"-13 x 3"
	G10111	2	Lock Nut, 1/2"-13
5	GD11895	1	Spacer, 4" x 8 1/4"
	G10038	1	Hex Head Cap Screw, 1/2"-13 x 3"
	G10111	1	Lock Nut, 1/2"-13
6	GB0218	6	Bushing, 2 1/32" I.D. x 7/8" O.D. x 1 9/32" Long
	G11391	6	Flat Washer, 5/8" SAE
	G10689	6	Carriage Bolt, 5/8"-11 x 2"
	G10107	6	Lock Nut, 5/8"-11

(IP1160)

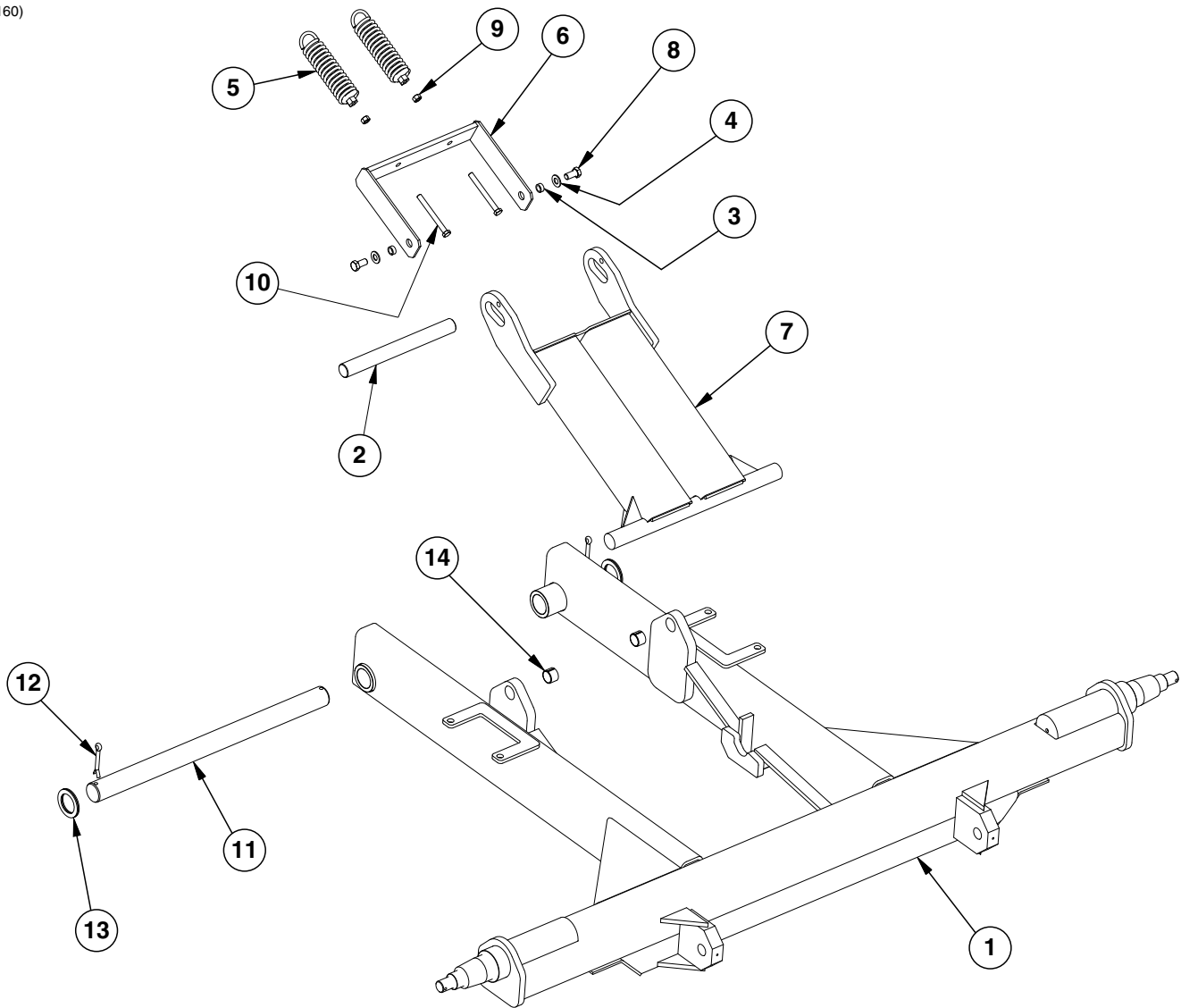

ITEM	PART NO.	QTY.	DESCRIPTION
1	GA9024	1	Axle W/Grease Fittings, 86 <sup>3</sup> / <sub>4</sub> ", 24 Row 30" (Non-Stock Item)
	GA9025	-	Axle W/Grease Fittings, 96 <sup>3</sup> / <sub>4</sub> ", 36 Row 20" (Non-Stock Item)
	G10640	4	Grease Fitting, 1/4"-28
2	GD11783	1	Transport Rod, 1 <sup>1</sup> / <sub>2</sub> " x 14 <sup>3</sup> / <sub>4</sub> "
3	GD3180-24	2	Sleeve, 5/8" I.D. x 7/8" O.D. x 3/8" Long
4	G11391	2	Flat Washer, 5/8" SAE
5	GA2068	2	Spring W/Plug
6	GA6725	1	Mechanical Trip Actuator
7	GA14086	1	Transport Lockup
8	G10055	2	Hex Head Cap Screw, 5/8"-11 x 1 <sup>1</sup> / <sub>4</sub> "
9	G10102	2	Hex Nut, 1/2"-13
10	G10348	2	Hex Head Cap Screw, 1/2"-13 x 5"
11	GD9566-01	1	Pin, 2 <sup>1</sup> / <sub>8</sub> " x 31 <sup>3</sup> / <sub>8</sub> "
12	G10461	2	Cotter Pin, 3/8" x 3"
13	G10234	4	Machine Bushing, 2 <sup>1</sup> / <sub>8</sub> ", 10 Gauge
14	GD11751	2	Steel Bushing, 1" Wide

(FF11d/A7434)

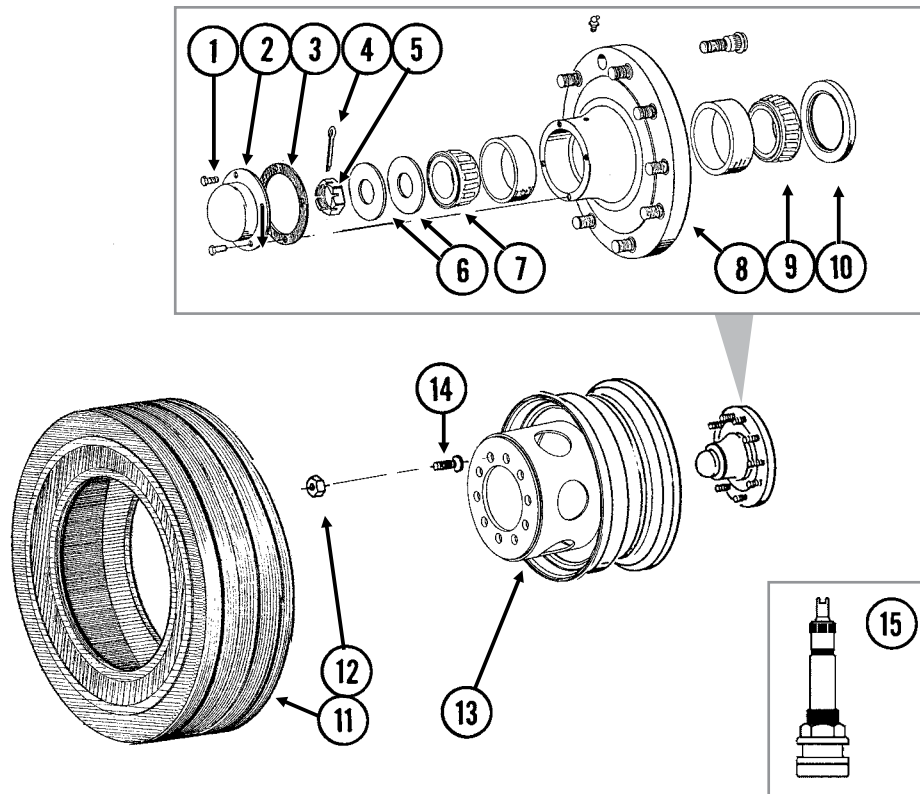

ITEM	PART NO.	QTY. (Per Assy.)	DESCRIPTION
1	G10376	4	Hex Head Cap Screw, 5/16"-18 x 3/4"
2	GD1529	1	Dust Cap
3	GD1536	1	Seal
4	G10460	1	Cotter Pin, 1/4" x 2"
5	G10070	1	Slotted Hex Nut, 1 1/4"-12
6	G11396	2	Flat Washer, 1 1/4"
7	GA0705	1	Outer Bearing
8	GA5965	1	Hub W/Cups, Grease Fitting And Stud Bolts (10 Bolt)
	GR0322	-	Outer Cup
	GD8532	-	Inner Cup
	G10373	-	Grease Fitting, 45°, 1/8"-27
	GR0257	-	Stud Bolt, 3/4"-16 x 2 1/2"
9	GA5987	1	Inner Bearing
10	GA5988	1	Seal
11	GD13352	-	Tire, 36" x 16" x 17.5", 14 Ply, Tubeless (Specify Brand*)
12	GD9509	10	Outer Budd Nut
13	GA6738	-	Rim, 18 1/2" Deep
14	GD9508	10	Inner Budd Nut, 2 1/4" Long
	GD12567	-	Inner Budd Nut, 2 5/8" Long
15	GA7434	1	Valve Stem

\* Specific brand requests will be supplied only as available from current Kinze Repair Parts stock. If a specific brand requested is not in stock, the brand available will be supplied.

PFA056(FF83d/FF113)

R.H. Side Shown

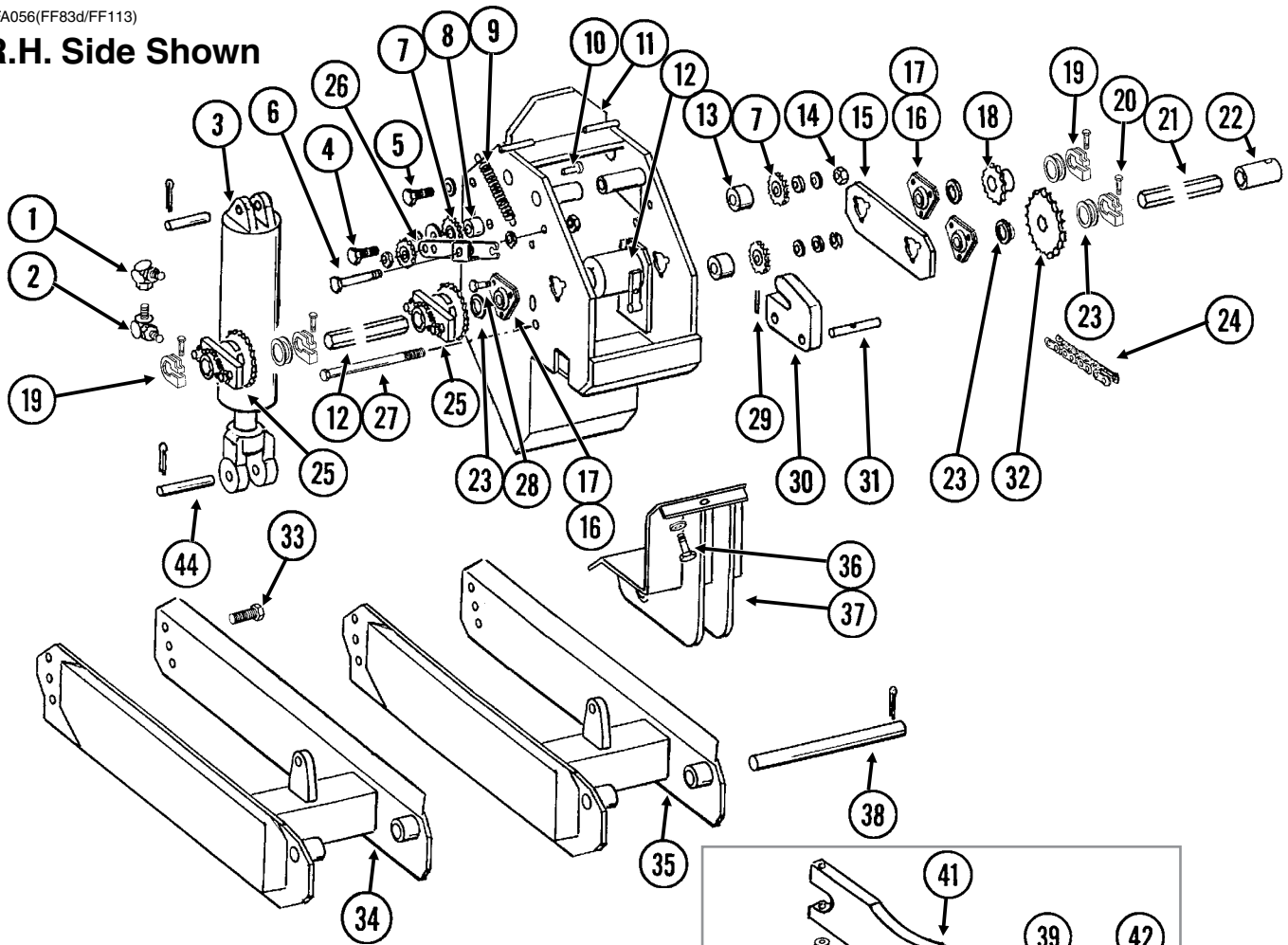

Long Wheel Arm

Short Wheel Arm

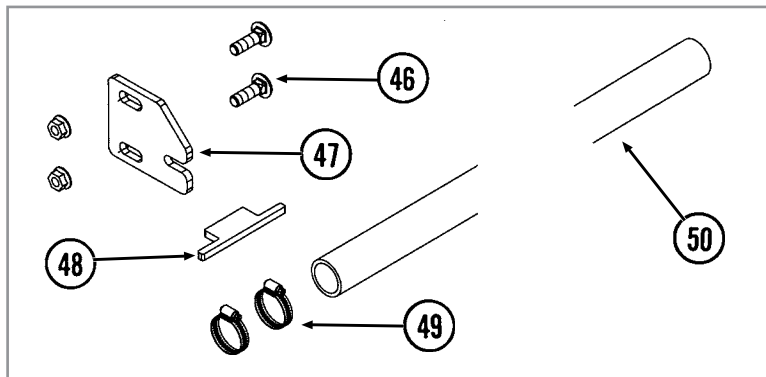
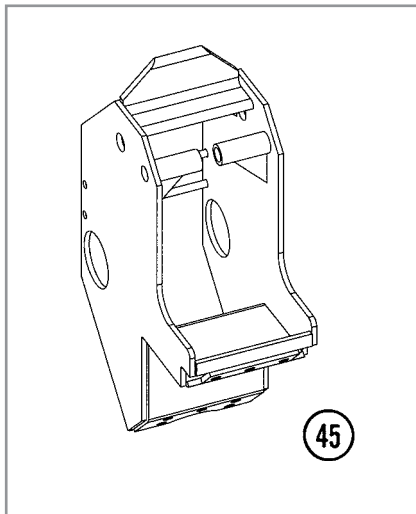
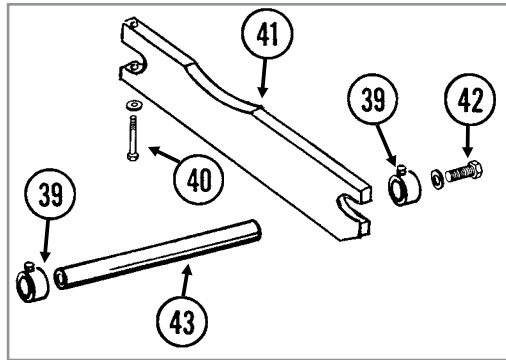

ITEM	PART NO.	QTY. (Per Machine)	DESCRIPTION
1	G6502-08	8	Swivel Elbow, 45°, ¾"-16 Male JIC To Female
2	G6801-08 GR1037	8 -	Elbow W/O-Ring, 90°, ¾"-16 Male JIC To O-Ring O-Ring
3	---	-	<a href="#">See "Master Cylinder" on page P135</a>
4	G10397 G11389 G10111	4 4 4	Hex Head Cap Screw, ½"-13 x 2¾" Flat Washer, ½" SAE Lock Nut, ½"-13
5	---	-	<a href="#">See "Contact Wheel Assembly" on page P111</a>
6	G10036 G10918 G10104 G10107	4 8 4 4	Hex Head Cap Screw, ⅝"-11 x 4" Machine Bushing, ⅝", 14 Gauge (If Applicable) Hex Nut, ⅝"-11 Lock Nut, ⅝"-11
7	GA7154	8	Sprocket W/Bearing, 18 Tooth
8	GB0258	4	Stepped Spacer, ⅞"
9	GD5857	4	Spring
10	G10860 G10166	4 4	Retaining Ring, ⅜" Clevis Pin, ⅜" x 1½"
11	A7323	-	Wheel Tower <b>(Non-Stock Item)</b>
12	---	-	<a href="#">See "Point Row Clutch" on page P113</a> <a href="#">See "Two-Speed Point Row Clutch" on page P115</a>
13	GD10637	8	Stepped Spacer, ½"
14	G10053 G10235 G10228 G10102	8 16 8 8	Hex Head Cap Screw, ½"-13 x 2½" Machine Bushing, ⅞", 14 Gauge Lock Washer, ½" Hex Nut, ½"-13
15	GD9482	2	Plate
16	G2100-03	-	Bearing, ⅞" Hex Bore, Spherical
17	G3400-01	-	Flangette
18	GA5113 GA5107	- -	Sprocket, 28 Tooth Sprocket, 19 Tooth
19	GD11045	-	Lock Clamp
20	G10130 G10923	- -	Square Head Machine Bolt, ⅝"-18 x 1¾" Flange Nut, ⅝"-18, No Serration
21	GD0914-24 GD0914-63	1 1	Hex Shaft, ⅞" x 24" (No Holes) Hex Shaft, ⅞" x 63" (No Holes)
22	---	-	<a href="#">See "Seed Rate Transmission and Driveline" on page P127</a>
23	G10233	-	Machine Bushing, 1", 10 Gauge (As Required)
24	G3310-82 GR0912	- -	Chain, No. 40, 82 Pitch Including Connector Link Connector Link, No. 40
25	---	2	<a href="#">See "Ratchet/Sprocket Assembly" on page P129</a>
26	GA9554 GA7154 G10017 G10128 G10501	4 - - - -	Idler W/Sprocket And Hardware, R.H. Sprocket W/Bearing, 18 Tooth Hex Head Cap Screw, ½"-13 x 1½" Machine Bushing, ½", 14 Gauge Hex Jam Nut, ½"-13, Grade 2
27	G10595 G10875 G11387 G10108	2 2 4 2	Hex Head Cap Screw, ⅜"-16 x 10" Hex Head Cap Screw, ⅜"-16 x 11" Flat Washer, ⅜" SAE Lock Nut, ⅜"-16

ITEM	PART NO.	QTY. (Per Machine)	DESCRIPTION
28	G10338	6	Carriage Bolt, 5/16"-18 x 1 1/4"
	G10303	18	Carriage Bolt, 5/16"-18 x 1"
	G10232	24	Lock Washer, 5/16"
	G10106	24	Hex Nut, 5/16"-18
29	G10606	4-6	Spring Pin, 1/4" x 2"
30	GD9514	4-6	Cylinder Pivot Mount
31	GD9515	4-6	Cylinder Anchor Pin, 1" x 6"
32	GA5194	-	Sprocket, 50 Tooth
33	---	-	<a href="#">See "Ground Drive Tire Assembly" on page P110</a>
34	GA8715	-	Long Wheel Arm W/Grease Fitting (Inner)
	G10640	-	Grease Fitting, 1/4"-28
35	GA8714	-	Short Wheel Arm W/Grease Fitting (Outer) (Lift Assist For 36 Row 20" Only)
	G10640	-	Grease Fitting, 1/4"-28
36	G10006	-	Hex Head Cap Screw, 5/8"-11 x 2 1/4"
	G11391	-	Flat Washer, 5/8" SAE
	G10230	-	Lock Washer, 5/8"
	G10104	-	Hex Nut, 5/8"-11
37	GA7324	4	Bracket W/Grease Fittings
	G10640	-	Grease Fitting, 1/4"-28
38	GD11695	4-6	Pin, 1 1/4" x 13 1/4"
	G10610	8-12	Spring Pin, 3/8" x 2"
39	GD10686	-	Special Lock Collar, Less Set Screws
	G10145	-	Square Head Set Screw, 5/16"-18 x 1/2"
40	G10035	-	Hex Head Cap Screw, 1/2"-13 x 4"
	G10228	-	Lock Washer, 1/2"
41	GD10316	-	Plate, Special Row Spacing Only
42	G10017	-	Hex Head Cap Screw, 1/2"-13 x 1 1/2"
	G10228	-	Lock Washer, 1/2"
43	GD10317	-	Shaft, Special Row Spacing Only
44	GD12585	8-10	Pin, 1 1/4" x 4 1/2"
	G10460	16-20	Cotter Pin, 1/4" x 2"
45	A11070	-	Wheel Tower (Center Wheel Module On 36 Row 20" Only) <b>(Non-Stock Item)</b>
46	G10599	2	Carriage Bolt, 3/8"-16 x 1 1/4"
	G10622	2	Serrated Flange Nut, 3/8"-16
47	GD17023	1	Plate
48	GD14115	1	Catch
49	G10278	2	Hose Clamp, No. 16
50	GD13652-02	1	Pipe, 1" x 50"
A	G1K269	-	Lock Clamp Kit (Items 19 And 20)

PFA056/PTD057(FF13e/A7434)

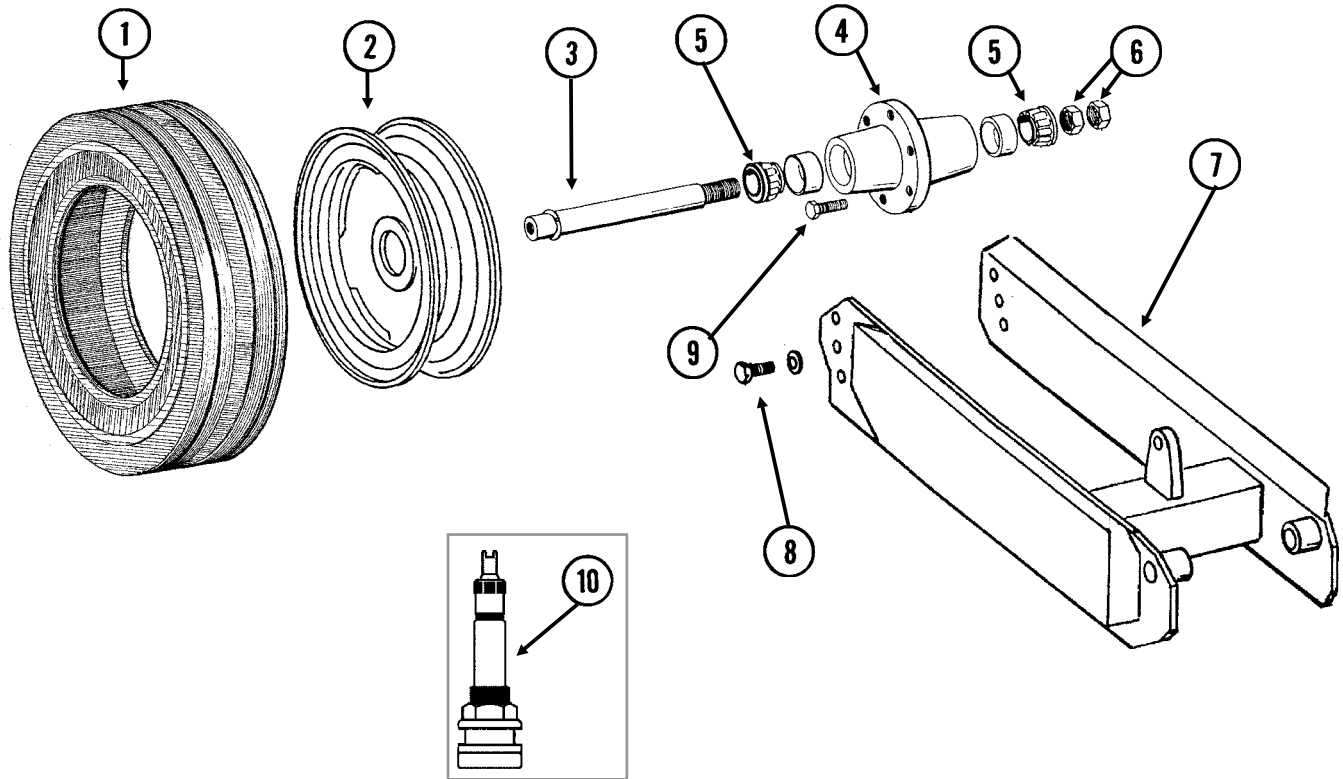

ITEM	PART NO.	QTY. (Per Assy.)	DESCRIPTION
1	GD13409	-	Tire, 255-70R 22.5" W/O Center Rib, Tubeless (Specify Brand*)
2	GA9619	-	Rim, 5.5" x 22.5"
3	GA4376	1	Spindle W/Round External Retaining Ring, 10"
	GD11490	-	Round External Retaining Ring
	GD11458	-	Spindle ( <b>Sub GA4376</b> )
4	GA2148	1	Hub W/Cups, 6 Bolt
	GR0434	-	Cup
5	GA0895	2	Bearing
6	G11081	2	Hex Jam Nut, 1½"-12, Grade 2
7	---	-	<a href="#">See "Wheel Module Assembly" on page P107</a>
8	G10026	2	Hex Head Cap Screw, ¾"-10 x 2"
	G10231	2	Lock Washer, ¾"
9	GR0270	6	Lug Bolt, 9/16"-18
10	GA7434	-	Valve Stem
A	GA9620	-	Tire And Rim Assembly W/O Center Rib (Items 1, 2 And 10) (Specify Brand*)
B	GA4377	-	Hub And Spindle Assembly (Items 3-6)

\*Specific brand requests will be supplied only as available from current Kinze Repair Parts stock. If a specific brand requested is not in stock, the brand available will be supplied.

(FF43e)

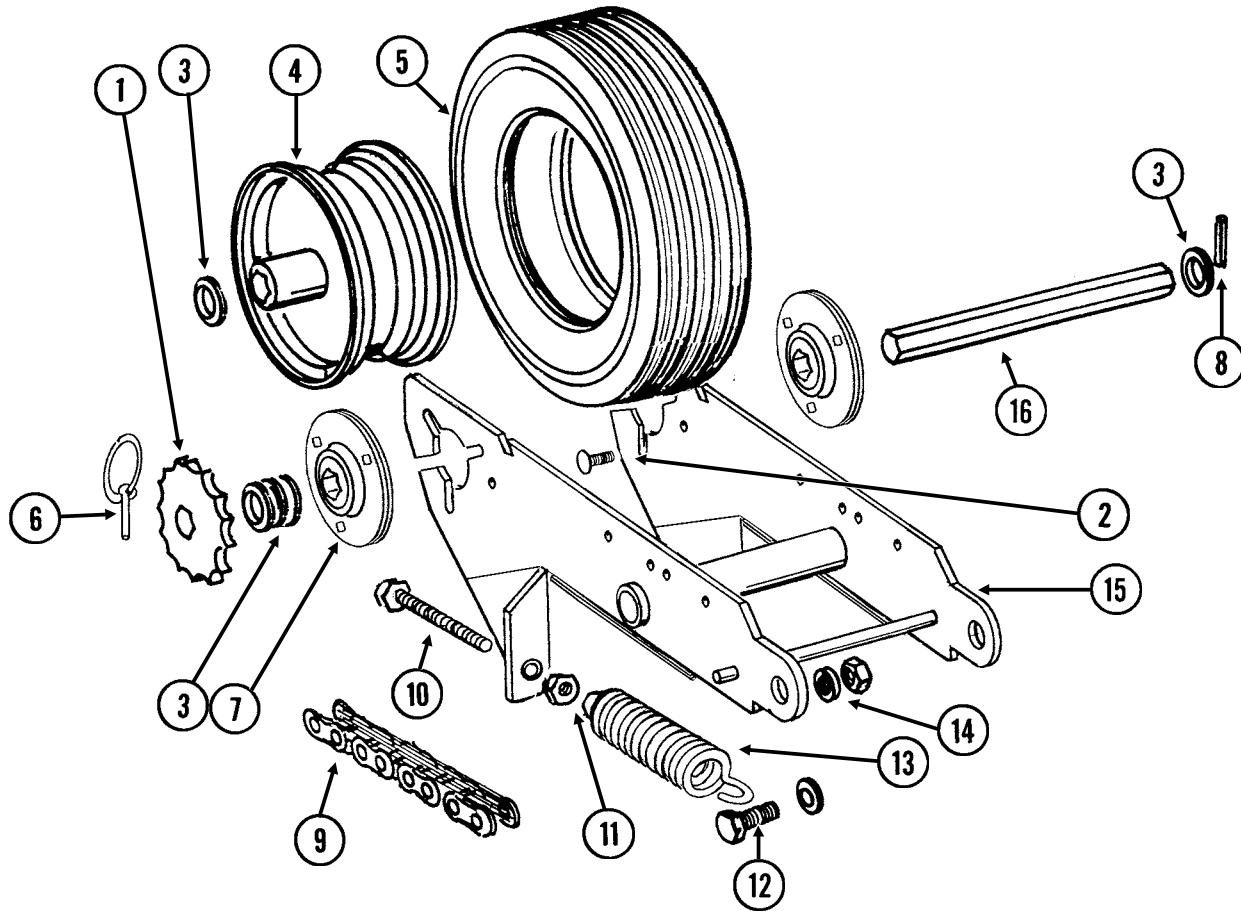

ITEM	PART NO.	QTY. (Per Assy.)	DESCRIPTION
1	GA12192	1	Sprocket, 22 Tooth
	GA5113	-	Sprocket, 28 Tooth
	GA12191	-	Sprocket, 44 Tooth
	GA5105	-	Sprocket, 15 Tooth
2	G10303	6	Carriage Bolt, 5/16"-18 x 1"
	G10620	6	Serrated Flange Nut, 5/16"-18
3	G10233	-	Machine Bushing, 1", 10 Gauge (As Required)
4	GA3553	1	Rim, 3.75" x 8"
	GD6989	1	Sleeve
5	GD4700	1	Tire, 4.80" x 8", 4 Ply, Rib Implement (Specify Brand*)
	GD4701	-	Valve Stem
6	GD2558	1	Lynch Pin, 1/4"
7	GA9846	2	Flanged Bearing, 7/8" Hex Bore
8	G10602	2	Spring Pin, 1/4" x 1 1/2"
9	G3310-148	1	Chain, No. 40, 148 Pitch Including Connector Link (Used With 22 Tooth Sprocket)
	G3310-150	1	Chain, No. 40, 150 Pitch Including Connector Link (Used With 28 Tooth Sprocket)
	G3310-158	1	Chain, No. 40, 158 Pitch Including Connector Link (Used With 44 Tooth Sprocket)
	G3310-144	1	Chain, No. 40, 144 Pitch Including Connector Link (Used With 15 Tooth Sprocket)
	GR0912	-	Connector Link, No. 40
10	G10890	2	Hex Head Adjusting Bolt, 1/2"-13 x 4", Grade 2
11	G10501	2	Hex Jam Nut, 1/2"-13, Grade 2
12	G10008	2	Hex Head Cap Screw, 5/8"-11 x 2"
	G10235	4	Machine Bushing, 7/8", 14 Gauge
	G11391	2	Flat Washer, 5/8" SAE
	G10107	2	Lock Nut, 5/8"-11
13	GA2068	2	Spring W/Plug
14	GB0218	2	Bushing, 2 1/32" I.D. x 7/8" O.D. x 1 9/32" Long
15	GA7372	1	Wheel Arm
16	GD6775	1	Hex Shaft, 7/8" x 11 3/4" (2 Holes)
A	GA3552	-	Tire And Rim Assembly (Items 4 And 5) (Specify Brand*)

\* Specific brand requests will be supplied only as available from current Kinze Repair Parts stock. If a specific brand requested is not in stock, the brand available will be supplied. Different brand tires may have different diameters. Change in tire brand may affect rates. Field checks are recommended after any change in contact tires.

PRC018/ECP013(TWL70g/TWL71d/TWL18/A10054)

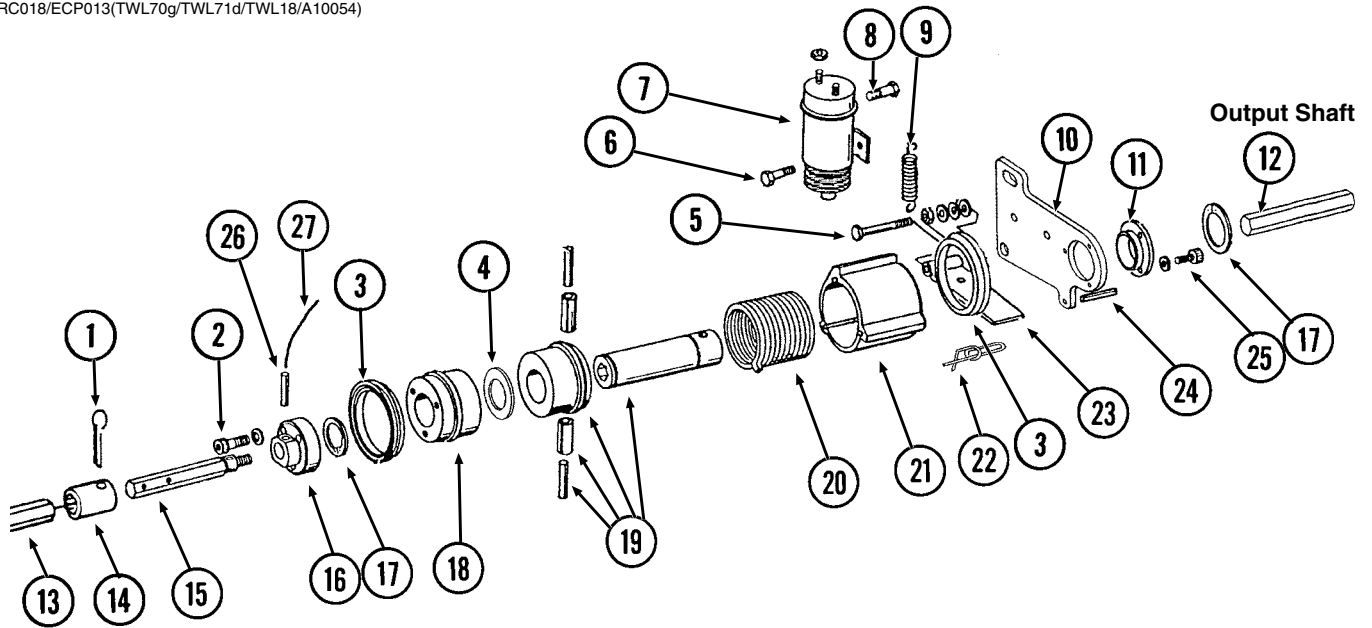

Input Shaft

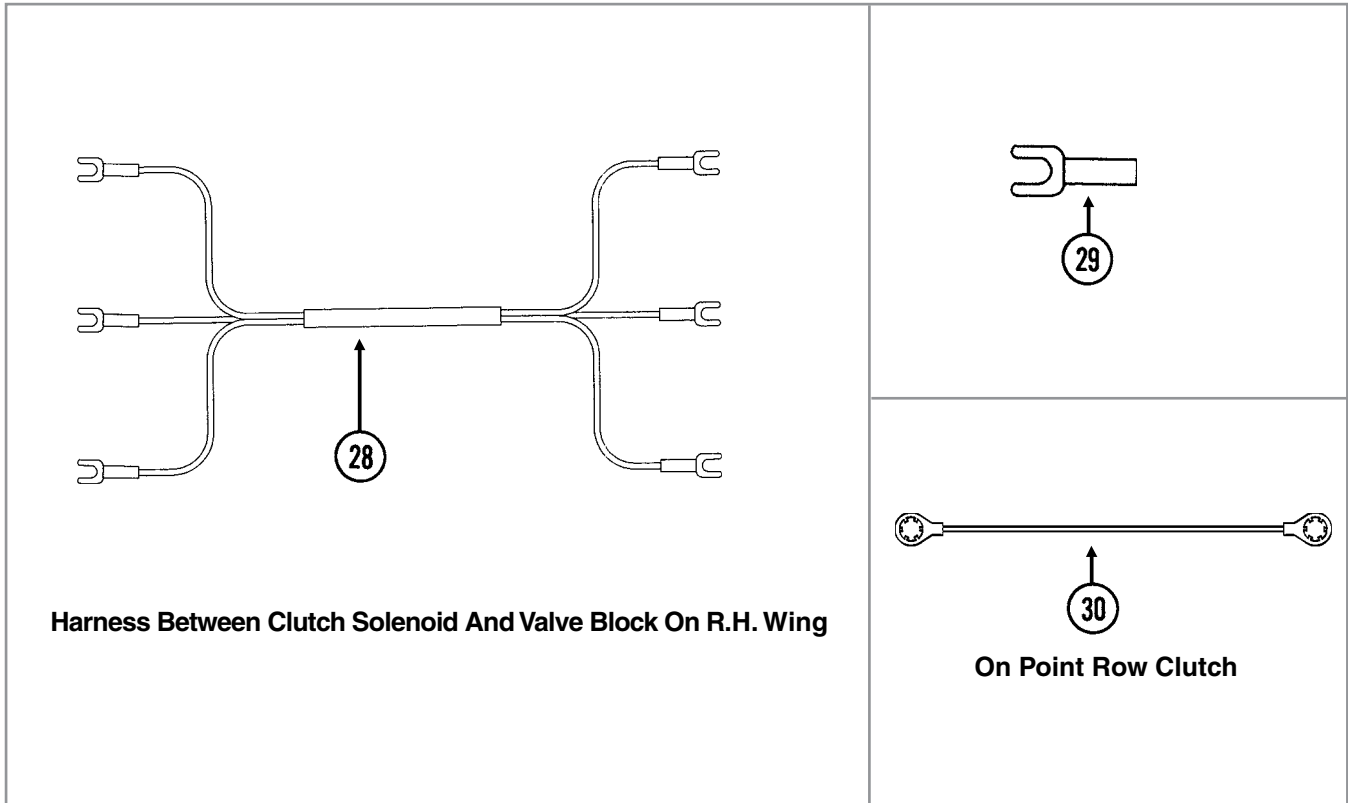

ITEM	PART NO.	QTY. (Per Assy.)	DESCRIPTION
1	G10460	1	Cotter Pin, 1/4" x 2"
2	G10374	3	Hex Socket Head Cap Screw, 1/4"-20 x 1"
	G10227	3	Lock Washer, 1/4"
3	GD14512	2	V-Ring Seal
4	GD14513	1	Felt Washer
5	G10049	1	Hex Head Cap Screw, 3/8"-16 x 2 1/2"
	G10101	1	Hex Nut, 3/8"-16
	G11387	1	Flat Washer, 3/8" SAE
	G10229	2	Lock Washer, 3/8"
	G10497	1	Hex Jam Nut, 3/8"-16, Grade 2
6	G10023	1	Hex Head Cap Screw, 1/4"-20 x 3/4"
	G10227	1	Lock Washer, 1/4"
	G10103	1	Hex Nut, 1/4"-20
7	GA8393	1	Solenoid Complete
	GR1306	1	Snap Ring
	GR1303	1	Spring
	GR1304	1	Boot
	GR1305	1	Plunger
8	G10900	1	Hex Socket Head Cap Screw, 1/4"-20 x 1 3/4", Grade 8
	G10227	1	Lock Washer, 1/4"
	G10103	2	Hex Nut, 1/4"-20
9	GD10123	1	Spring
10	GD10103	1	Mounting Plate
11	GD9667	1	Bushing
12	GD0914-10	1	Hex Shaft, 7/8" x 10" (No Holes)
13	GD0914-32	1	Hex Shaft, 7/8" x 32" (No Holes)
14	GD7867	1	Coupler, 3"
15	GD10068	1	Input Shaft, R.H. Threads
16	GD10070	1	Coupler W/R.H. Threads
17	G10496	2	External Inverted Snap Ring, 1 1/2"
18	GD10104	1	Input Hub
19	GA7137	1	Hub/Sleeve Assembly W/Spring Pins
	G10765	-	Spring Pin, 1/4" x 1"
	G10804	-	Spring Pin, 5/32" x 7/8"
20	GD9671	-	Spring, L.H.
21	GD10102	1	Stop Collar
22	GD11120	1	Rue Ring Cotter, 5/16"
23	GD10510	1	Actuator Arm
24	G10859	1	Spring Pin, 3/16" x 2 1/4"
25	G10253	3	Hex Socket Head Screw, No. 10-32 x 1/2"
	G10257	3	Lock Washer, No. 10
26	G10546	1	Spring Pin, 3/16" x 1 1/4"
27	GD13524-01	1	Lock Wire, 10", Stainless Steel
28	GA9479	1	Wiring Harness, 228", R.H. Side Of Machine
	GA9512	-	Wiring Harness, 516", L.H. Side Of Machine
29	G10996	-	Fork Terminal
30	GA10054	-	Ground Cable, Green
A	GA7111	-	Point Row Clutch Assembly, L.H. (Items 2-11, 15-27, and 30)

PRC023(FF47c/A7274/A10054)

Output Shaft

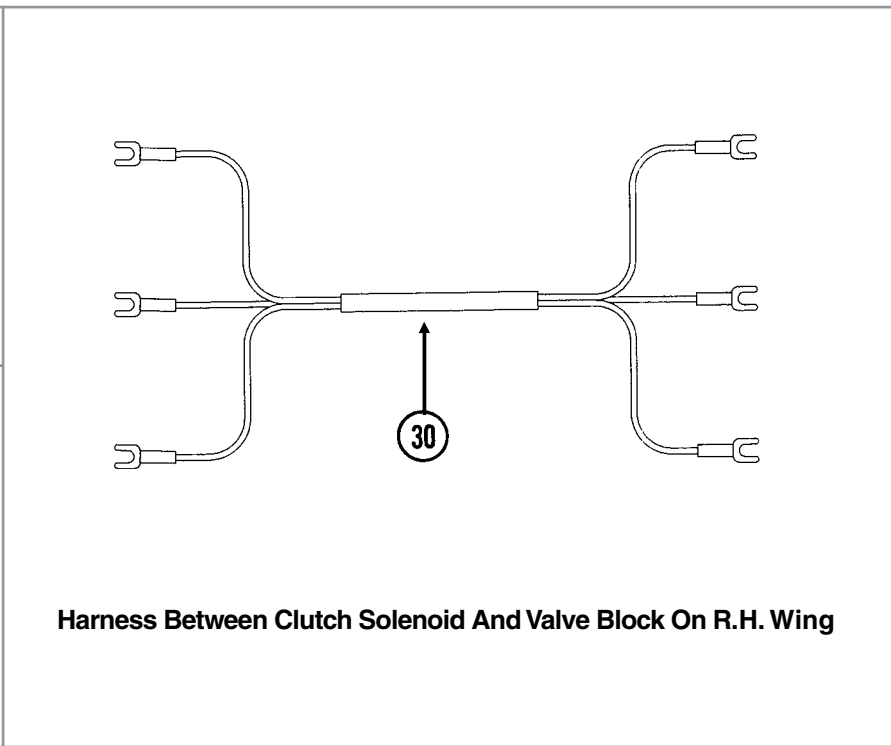
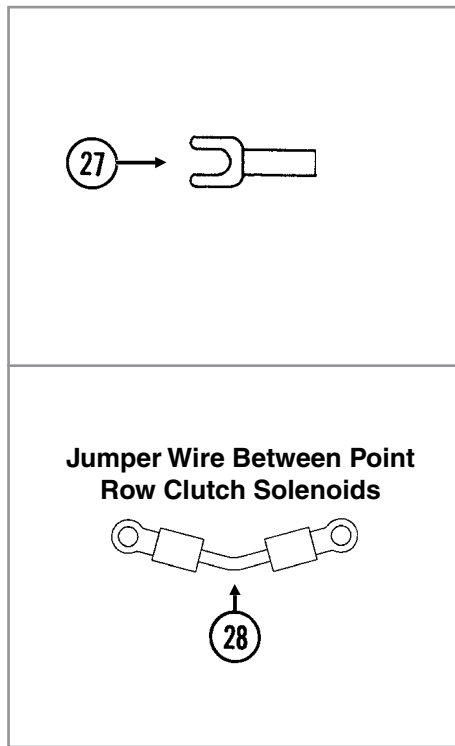
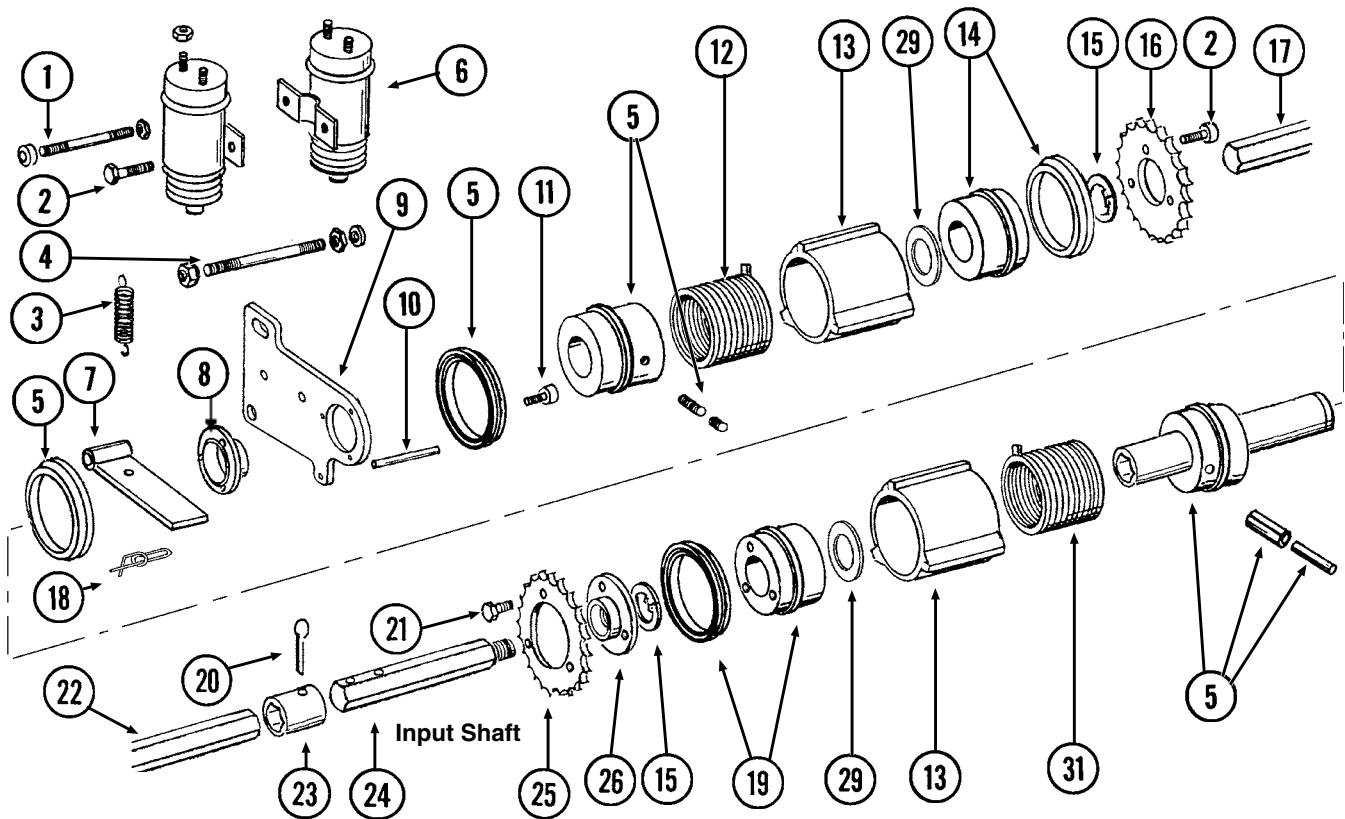

ITEM	PART NO.	QTY. (Per Assy.)	DESCRIPTION
1	GD10635	1	Threaded Rod, 1/4"-20 x 3 1/2"
	G10103	2	Hex Nut, 1/4"-20
	G10227	2	Lock Washer, 1/4"
	GD10282	2	Allen Nut, 1/4"-20
2	G10023	4	Hex Head Cap Screw, 1/4"-20 x 3/4"
	G10227	4	Lock Washer, 1/4"
	G10103	1	Hex Nut, 1/4"-20
3	GD10123	2	Spring
4	GD10636	1	Threaded Rod, 3/8"-16 x 4 1/4"
	G10108	2	Lock Nut, 3/8"-16
	G10229	2	Lock Washer, 3/8"
	G10101	2	Hex Nut, 3/8"-16
5	GA7463	1	Hub/Sleeve Assembly W/Seals, Sleeve, Pins And Screws
	GD10120	-	Seal
	GD10584	-	Sleeve
	G10873	-	Hex Socket Set Screw, 5/16"-18 x 3/4"
	G10872	-	Hex Socket Set Screw, 5/16"-18 x 1/4"
	G10804	-	Spring Pin, 5/32" x 7/8"
	G10765	-	Spring Pin, 1/4" x 1"
6	GA8393	2	Solenoid Complete
	GR1306	-	Snap Ring
	GR1303	-	Spring
	GR1304	-	Boot
	GR1305	-	Plunger
7	GD10510	2	Actuator Arm
8	GD10586	1	Bushing
9	GD10103	1	Mounting Plate
10	G10859	1	Spring Pin, 3/16" x 2 1/4"
11	G10876	3	Hex Socket Head Screw, No. 10-32 x 1/4"
12	GD9671	2	Spring, L.H.
13	GD10585	2	Stop Collar
14	GA9572	1	Hub W/Seal
	GD10120	-	Seal
15	G10496	2	External Inverted Snap Ring, 1 1/2"
16	GD10579	1	Output Sprocket, 28 Tooth
17	GD0914-10	1	Hex Shaft, 7/8" x 10" (No Holes)
18	GD11120	2	Rue Ring Cotter, 5/16"
19	GA9571	1	Hub W/Seal
	GD10120	-	Seal
20	G10460	1	Cotter Pin, 1/4" x 2"
21	G10374	3	Hex Socket Head Cap Screw, 1/4"-20 x 1"
	GD10588	3	Key
22	GD0914-32	1	Hex Shaft, 7/8" x 32" (No Holes)
23	GD7867	1	Coupler, 3"
24	GD10068	1	Input Shaft, R.H. Threads
25	GD10578	1	Input Sprocket, 28 Tooth
26	GD10638	1	Coupler W/R.H. Threads
27	G10996	-	Fork Terminal
28	GA7274	1	Jumper Wire W/Ring Terminals, 2 3/16"
29	GD14513	2	Felt Washer
30	GA9479	1	Wiring Harness, 228", R.H. Side Of Machine
	GA9512	-	Wiring Harness, 516", L.H. Side Of Machine
31	GD9672	-	Spring, R.H.

(FF48c)

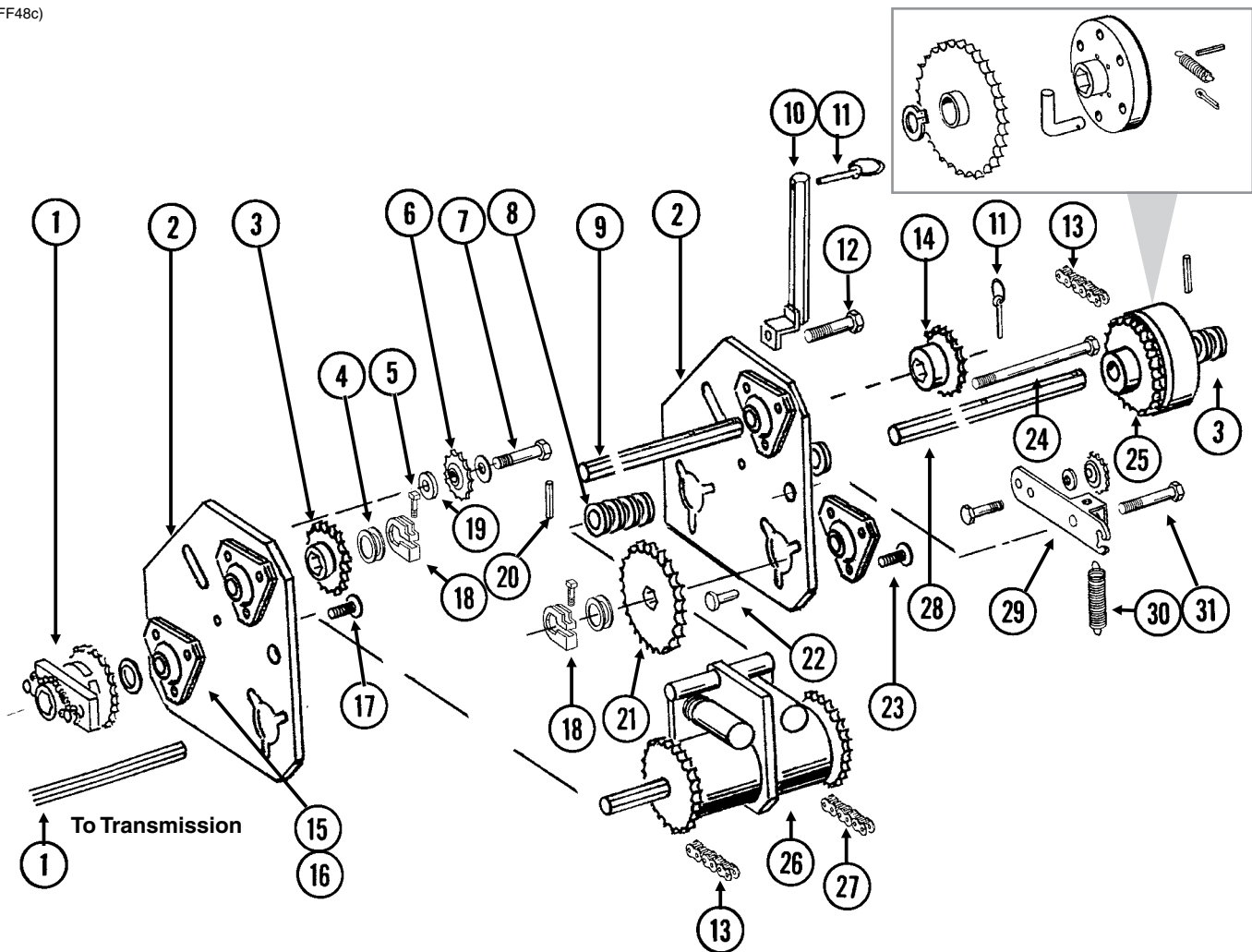

ITEM	PART NO.	QTY. (Per Assy.)	DESCRIPTION
1	---	-	<a href="#">See "Wheel Module Assembly" on page P107</a>
2	GD10327	2	Extension Plate
3	GA5113	1	Sprocket, 28 Tooth
4	G10233	1	Machine Bushing, 1", 10 Gauge
5	G10130	1	Square Head Machine Bolt, 5/16"-18 x 1 3/4"
	G10923	1	Flange Nut, 5/16"-18, No Serration
6	GA7154	1	Sprocket W/Bearing, 18 Tooth
7	G10053	1	Hex Head Cap Screw, 1/2"-13 x 2 1/2"
	G10168	1	Machine Bushing, 1/2", 7 Gauge
	G11389	3	Flat Washer, 1/2" SAE
	G10228	1	Lock Washer, 1/2"
	G10102	1	Hex Nut, 1/2"-13
8	G10233	-	Machine Bushing, 1", 10 Gauge (As Required)
9	GD10547	1	Jack Shaft, 7/8" x 13"
10	GA7313	1	Sprocket Storage Rod
11	GD2558	2	Lynch Pin, 1/4"
12	G10037	1	Hex Head Cap Screw, 1/2"-13 x 1 1/4"
	G11389	1	Flat Washer, 1/2" SAE
	G10228	1	Lock Washer, 1/2"
	G10102	1	Hex Nut, 1/2"-13

ITEM	PART NO.	QTY. (Per Assy.)	DESCRIPTION
13	G3310-68	2	Chain, No. 40, 68 Pitch Including Connector Link
	GR0912	-	Connector Link, No. 40
	GR0911	-	Offset Link, No. 40
14	GA5105	1	Sprocket, 15 Tooth
	GA5106	1	Sprocket, 17 Tooth
	GA5109	-	Sprocket, 24 Tooth
	GA5112	1	Sprocket, 27 Tooth
	GA5108	-	Sprocket, 23 Tooth (From Transmission)
	GA5110	-	Sprocket, 25 Tooth (From Transmission)
	GA5111	-	Sprocket, 26 Tooth (From Transmission)
15	G3400-01	-	Flangette
16	G2100-03	-	Bearing, 7/8" Hex Bore, Spherical
17	G10338	3	Carriage Bolt, 5/16"-18 x 1 1/4"
	G10232	3	Lock Washer, 5/16"
	G10106	3	Hex Nut, 5/16"-18
18	GD11045	1	Lock Clamp
19	GD10637	1	Stepped Spacer, 1/2"
20	G10602	2	Spring Pin, 1/4" x 1 1/2"
21	GA5194	1	Sprocket, 50 Tooth
22	G10408	1	Clevis Pin, 5/16" x 3/4"
	G10409	1	Retaining Ring, 5/16"
23	G10302	9	Carriage Bolt, 5/16"-18 x 7/8"
	G10232	9	Lock Washer, 5/16"
	G11386	-	Flat Washer, 5/16" SAE
	G10106	9	Hex Nut, 5/16"-18
24	G10595	1	Hex Head Cap Screw, 3/8"-16 x 10"
	G10108	1	Lock Nut, 3/8"-16
25	GA7321	-	Overrunning Sprocket Assembly, L.H.
	G10430	1	External Retaining Ring, 1 1/4"
	GD1255	6	L-Pin
	G10546	6	Spring Pin, 3/16" x 1 1/4"
	G10470	6	Cotter Pin, 5/32" x 1"
	GD10366	6	Spring
	GA7317	1	Block
	GA7319	1	Sprocket W/Bushing, 30 Tooth
26	---	-	<a href="#">See "Two-Speed Point Row Clutch" on page P115</a>
27	G3310-82	1	Chain, No. 40, 82 Pitch Including Connector Link
	GR0912	-	Connector Link, No. 40
	GR0911	-	Offset Link, No. 40
28	GD10548	1	Output Shaft, 7/8" x 12"
29	GA9919	1	Idler W/Sprocket And Hardware, R.H.
	GA7154	-	Sprocket W/Bearing, 18 Tooth
	G10017	-	Hex Head Cap Screw, 1/2"-13 x 1 1/2"
	G10128	-	Machine Bushing, 1/2", 14 Gauge
	G10501	-	Hex Jam Nut, 1/2"-13, Grade 2
30	GD5857	2	Spring
31	G10036	1	Hex Head Cap Screw, 5/8"-11 x 4"
	G11391	1	Flat Washer, 5/8" SAE
	G10107	1	Lock Nut, 5/8"-11
	G10104	1	Hex Nut, 5/8"-11
A	G1K269	-	Lock Clamp Kit (Items 5 And 18)

IP1175

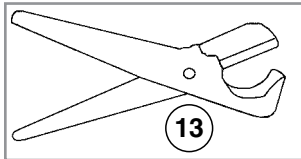
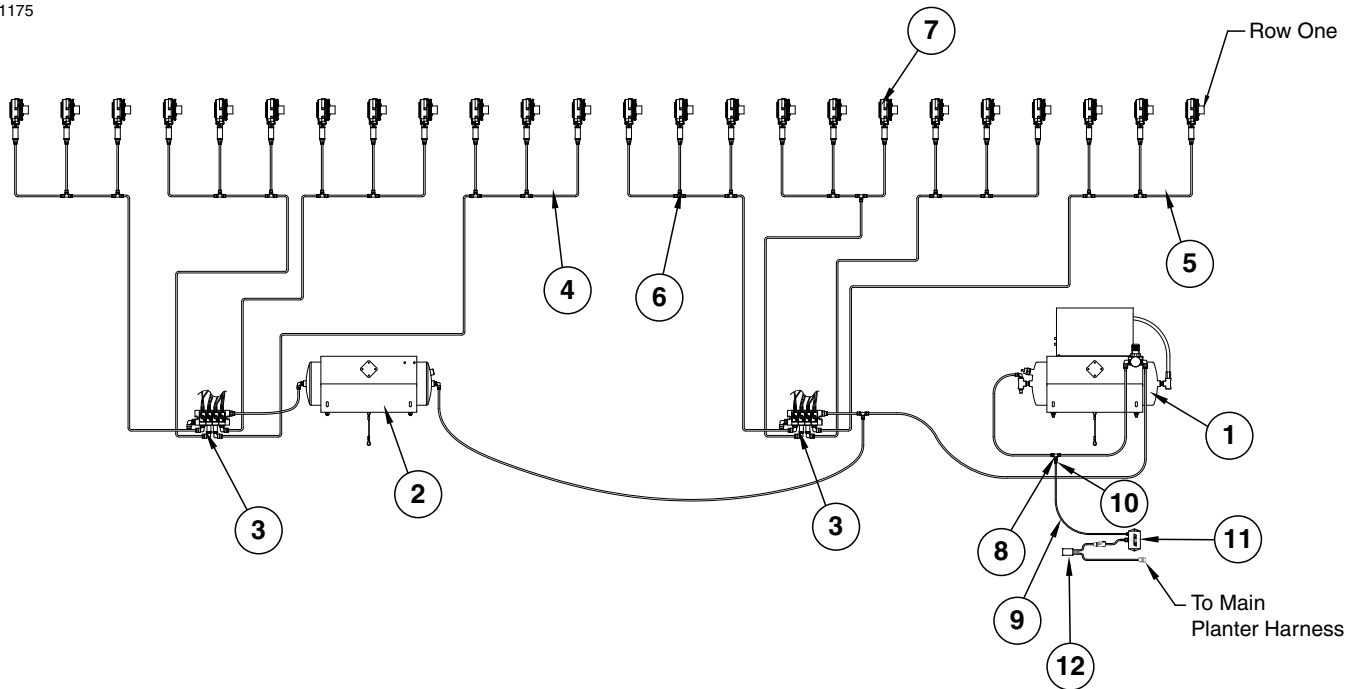

ITEM	PART NO.	QTY.	DESCRIPTION
1	---	1	<a href="#">See "Air Compressor and Dual Solenoid Assembly" on page P123</a>
2	---	1	<a href="#">See "Accumulator Assembly" on page P125</a>
3	---	2	<a href="#">See "Clutch Valve Assembly" on page P154</a>
4	GD17151-01	3	Nylon Tubing, 1/4" O.D. x 52', 24 Row
5	GD17151-01	3	Nylon Tubing, 1/4" O.D. x 52', 24 Row
6	GD18015	-	Tee, 1/4" Press On
7	---	-	<a href="#">See "Air Clutch, Pull Row Unit" on page P5</a>
8	GD18010	-	Tee, 3/8" Tube Union
9	GD17151-06	-	Nylon Tubing, 1/4" O.D. x 1 1/2'
10	GD18796	-	Reducer, 3/8" To 1/4"
11	GA14846	-	High Pressure Sensor (0-120 PSI)
12	GA12812	-	Hall Effect Adapter
13	GA13169	1	Tube Cutter W/Blade
	GR1843	-	Blade

(IP1176)

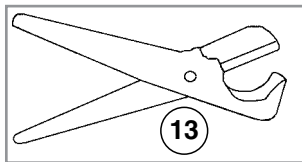
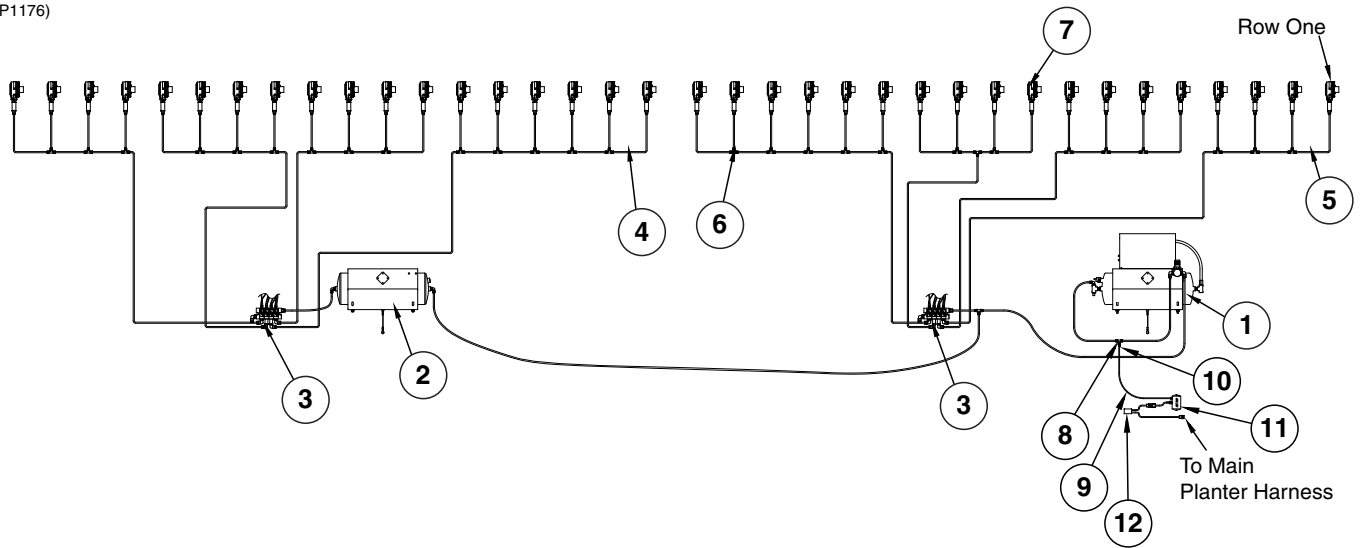

ITEM	PART NO.	QTY.	DESCRIPTION
1	---	1	<a href="#">See "Air Compressor and Dual Solenoid Assembly" on page P123</a>
2	---	1	<a href="#">See "Accumulator Assembly" on page P125</a>
3	---	2	<a href="#">See "Clutch Valve Assembly" on page P154</a>
4	GD17151-01	4	Nylon Tubing, 1/4" O.D. x 52'
5	GD17151-01	-	Nylon Tubing, 1/4" O.D. x 52'
6	GD18015	29	Tee, 1/4" Press On (Air Clutch)
7	---	-	<a href="#">See "Air Clutch, Pull Row Unit" on page P5</a>
8	GD18010	-	Tee, 3/8" Tube Union
9	GD17151-06	-	Nylon Tubing, 1/4" O.D. x 1 1/2'
10	GD18796	-	Reducer, 3/8" To 1/4"
11	GA14846	-	High Pressure Sensor (0-120 PSI)
12	GA12812	-	Hall Effect Adapter
13	GA13169	1	Tube Cutter W/Blade
	GR1843	-	Blade

(PNE01i/MTR27a/ELC27b/MTR45/MTR27i)

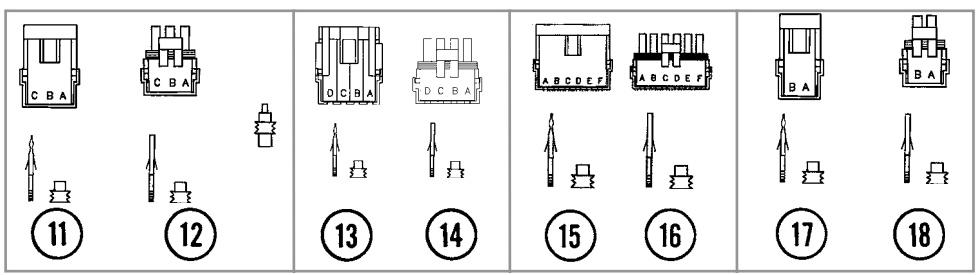
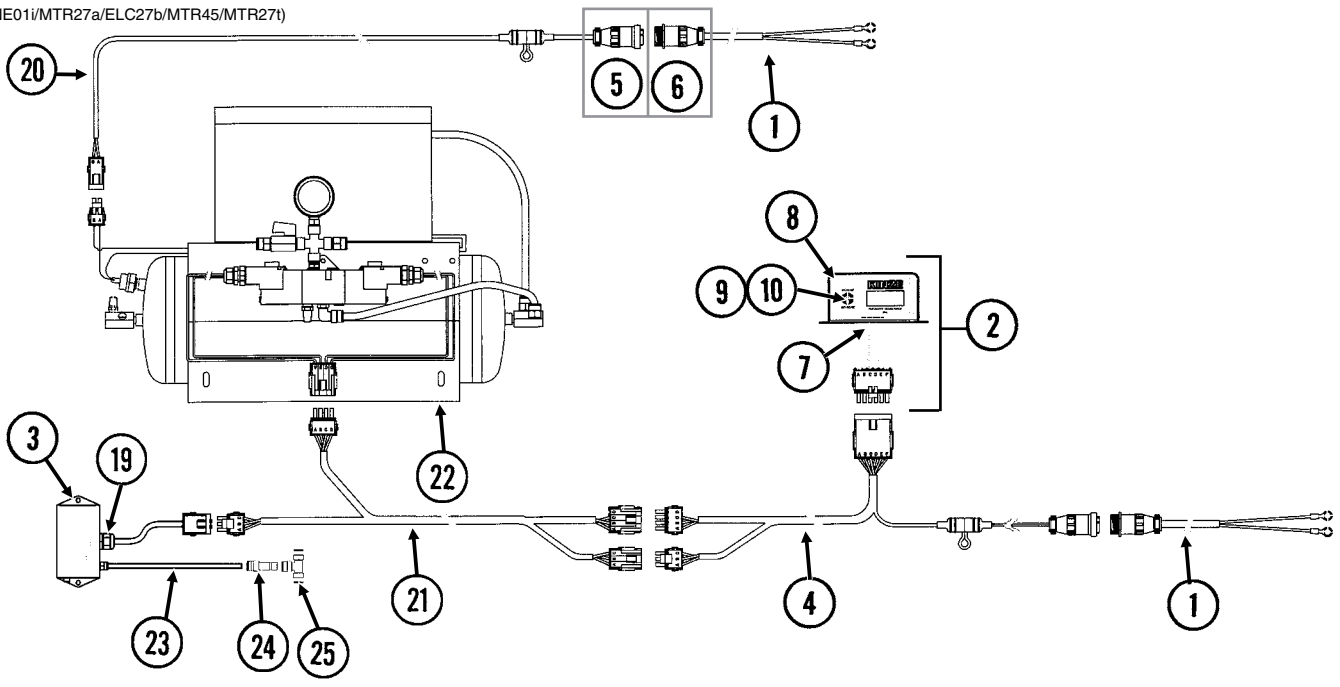

ITEM	PART NO.	QTY.	DESCRIPTION
1	GA7856	2	Power Lead Adapter
2	GA12644	1	Control Console Assembly
3	GA14846	1	High Pressure Sensor (0-120 PSI)
4	GA12645	1	Wiring Harness W/Fuse Holder And Fuse, 206"
	GD14258	-	Fuse Holder
	GD14660	-	Fuse, 2 Amp Delay Action
5	G1K268	-	Console Cable Connector Kit, Includes: (1) 3-Pin Connector, (1) Cable Clamp, (1) Lock Ring, (3) Female Terminal Pins
6	G1K267	-	Console Cable Connector Kit, Includes: (1) 3-Pin Connector, (1) Cable Clamp, (3) Male Terminal Pins
7	GA9963	1	Strain Relief
8	GR1292	4	Pan Head Screw, No. 8-32 x 1/2"
9	GR1363	1	Hex Face Nut, 1 1/2"-32
10	GA6978	1	Switch, 3 Position Toggle, ON-OFF-ON
11	G1K248	-	3-Pin Female Connector Kit (Black), Includes: (3) 3-Pin Female Housings, (9) Pin Contacts, (9) Seals
12	G1K252	-	3-Pin Male Connector Kit (Black), Includes: (3) 3-Pin Male Housings, (9) Socket Contacts, (9) Seals
13	GA8328	-	4-Pin Female Connector Kit, Includes: (1) 4-Pin Female Housing, (4) Pin Contacts, (4) Seals
14	GA8329	-	4-Pin Male Connector Kit, Includes: (1) 4-Pin Male Housing, (4) Socket Contacts, (4) Seals
15	G1K396	-	6-Pin Female Connector Kit (Black), Includes: (3) 6-Pin Female Housings, (18) Pin Contacts, (18) Seals
16	G1K395	-	6-Pin Male Connector Kit (Black), Includes: (3) 6-Pin Male Housings, (18) Socket Contacts, (18) Seals
17	G1K321	-	2-Pin Female Connector Kit (Black), Includes: (3) 2-Pin Female Housings, (6) Pin Contacts, (6) Seals
18	G1K320	-	2-Pin Male Connector Kit (Black), Includes: (3) 2-Pin Male Housings, (6) Socket Contacts, (6) Seals
19	GA9964	2	Strain Relief
20	GA12682	1	Wiring Harness W/Fuse Holder And Fuse, 40'
	GD14258	-	Fuse Holder
	GD18275	-	Fuse, 20 Amp
21	GA12669	1	Wiring Harness, 40'
22	---	-	<a href="#">See "Air Compressor and Dual Solenoid Assembly" on page P123</a>
23	GD17151-06	1	Nylon Tubing, 1/4" O. D. x 1 1/2'
24	GD18796	1	Reducer, 3/8" To 1/4"
25	GD18010	1	Tee, 3/8" Tube Union

(IP1281)

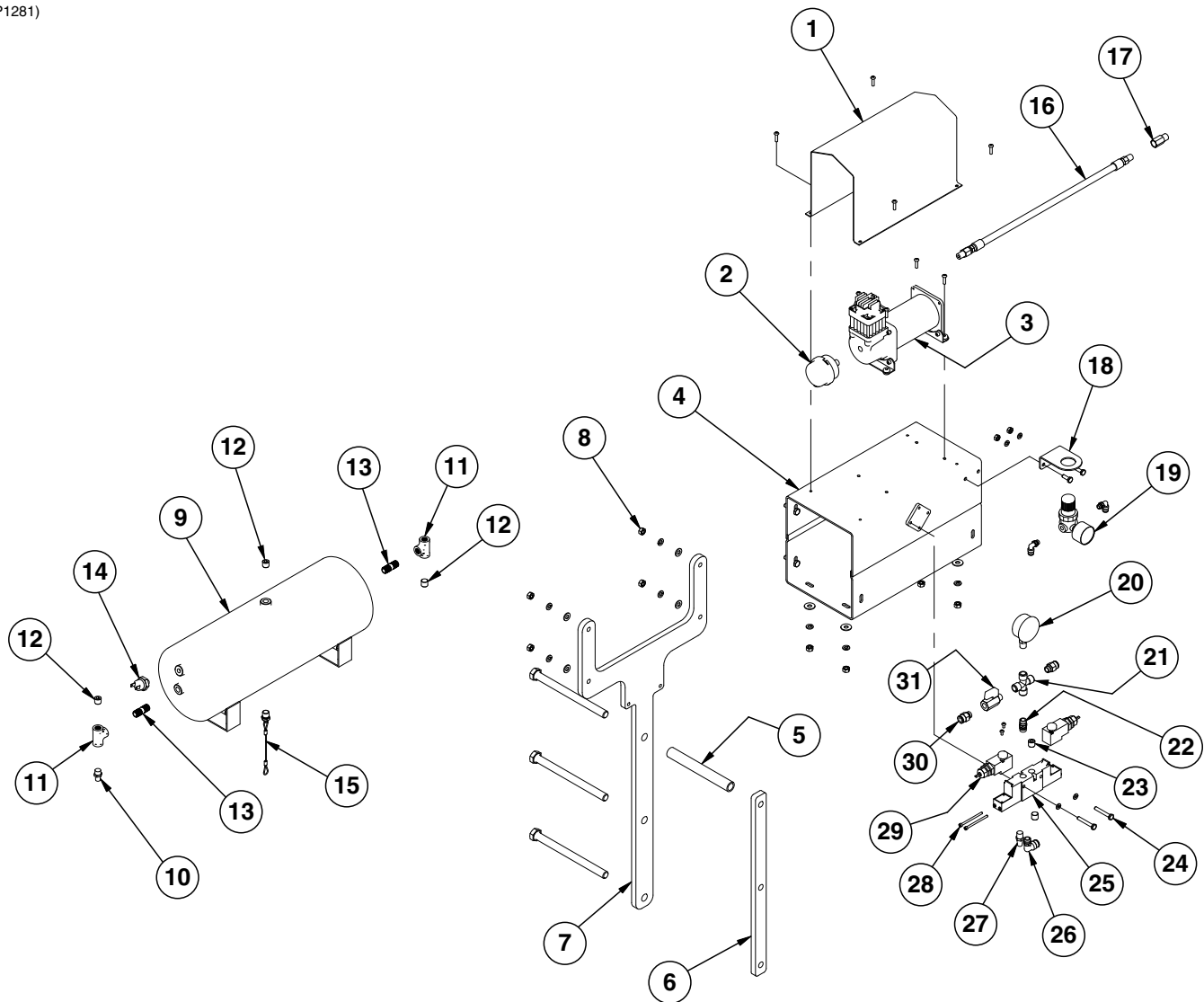

ITEM	PART NO.	QTY.	DESCRIPTION
1	GD18112	1	Cover
	G11066	4	Phillips Pan Head Machine Screw, No. 10-24 x 3/4", Stainless Steel
	G10992	4	Serrated Flange Nut, No. 10-24
2	GA14127	1	Filter Assembly
	GR1943	-	Filter
3	GA12102	1	Air Compressor
	G11066	4	Phillips Pan Head Machine Screw, No. 10-24 x 3/4", Stainless Steel
	G10992	4	Serrated Flange Nut, No. 10-24
4	GA12358	1	Mount
	G10019	4	Hex Head Cap Screw, 5/16"-18 x 1"
	G10232	4	Lock Washer, 5/16"
	G10219	4	Washer, 5/16" USS
	G10106	4	Hex Nut, 5/16"-18
5	GD3180-33	1	Sleeve, 7"
6	GD18901	1	Tap Block, Long

ITEM	PART NO.	QTY.	DESCRIPTION
7	GD20044	1	Bracket
	G10341	3	Hex Head Cap Screw, 5/8"-11 x 8"
8	G10106	4	Hex Nut, 5/16"-18
	G10232	4	Lock Washer, 5/16"
	G11386	4	Flat Washer, 5/16" SAE
	G10171	4	Hex Head Cap Screw, 5/16"-18 x 1 1/4"
9	GA11988	1	Tank, 3 Gallon
10	GA13512	1	Valve Stem, 1/4" NPT
11	GD19237	2	Tee, 1/4" NPT
12	GD17156	3	Plug, 1/4" NPT
13	GD19238	2	Close Nipple, 1/4" NPT
14	GR1778	1	Pressure Switch
15	GA11991	1	Drain, 1/4" NPT
16	GR1951	1	Leader Hose without Check Valve
17	GR1921	1	Check Valve
18	GD18084	1	Regulator Bracket
	G10023	2	Hex Head Cap Screw, 1/4"-20 x 3/4"
	G10227	2	Lock Washer, 1/4"
	G10103	2	Hex Nut, 1/4"-20
19	GA12629	1	Mini Regulator W/Gauge
	GD19080	2	Elbow, 1/4" x 1/8" NPT Swivel
20	GA12104	1	Pressure Gauge, 1/4" NPT
21	GD18078	1	Female Cross, 1/4" NPT
22	GD17154	1	Connector, 1/4" Male NPT
23	GD17156	2	Plug, 1/4" NPT
24	G10040	2	Hex Head Cap Screw, 1/4"-20 x 1 3/4"
	G10227	2	Lock Washer, 1/4"
25	GA11993	1	Block
26	GD17143	1	Swivel Elbow, 1/4" NPT x 3/8"
27	GA11997	1	Breather, 1/4" NPT
28	GR1952	4	Socket Head Cap Screw, #8-32 x 2"
	GR1953	4	O-Ring
	G10256	4	Lock Washer, No. 8
29	GA11994	2	Solenoid
	G11311	4	Phillips Pan Head Machine Screw
30	GD17141	2	Connector, 1/4" Male NPT
31	GA11992	1	Shutoff Valve, 1/4" NPT
A	GA12626	-	Air Compressor Assembly (Items 1-4, and 9-15)
B	GA11995	-	Dual Solenoid Assembly (Items 20-31) (only applicable with pneumatic down pressure option)
C	GR1783	-	Valve Seal Repair Kit

(IP1040a)

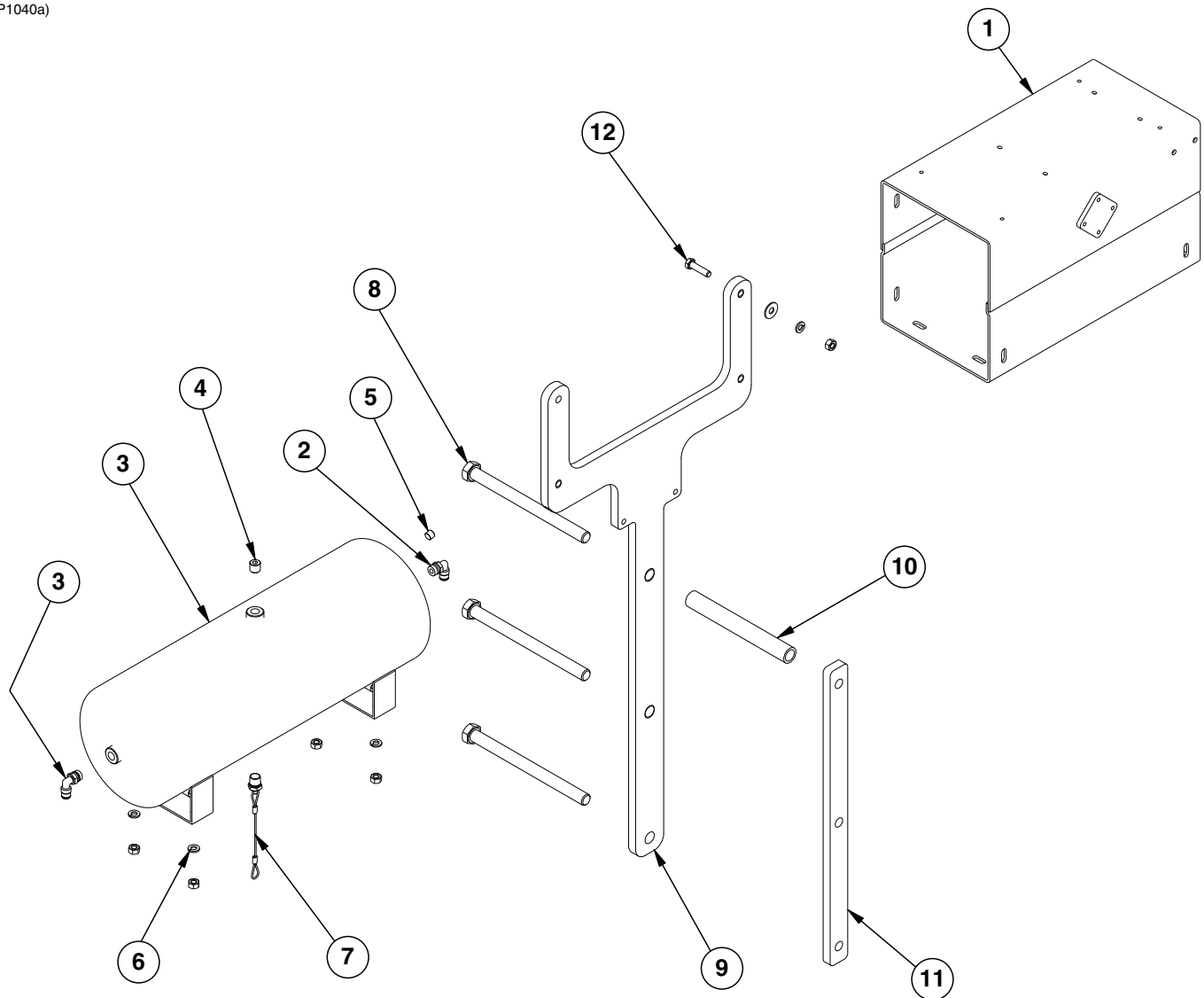

ITEM	PART NO.	QTY.	DESCRIPTION
1	GA12358	1	Compressor Mount
2	GA11988	1	Tank, 3 Gallon
3	GD17148	2	Male Connector, 1/4"
4	GD17156	1	Plug, 1/4" NPT
5	GD19079	1	Plug, 1/8" NPT
6	G10620	4	Serrated Flange Nut, 5/16"-18
	G10043	4	Hex Head Cap Screw, 5/16"-18 x 3/4"
7	GA11991	1	Drain, 1/4" NPT
8	G10341	3	Hex Head Cap Screw, 5/8"-11 x 8"
9	GD20044	1	Bracket
10	GD3180-33	1	Sleeve, 7"
11	GD18901	1	Tap Block, Long
12	G10171	4	Hex Head Cap Screw, 5/16"-18 x 1 1/4"
	G10232	4	Lock Washer, 5/16"
	G10219	4	Washer, 5/16" USS
	G10106	4	Hex Nut, 5/16"-18

**This page left blank intentionally.**

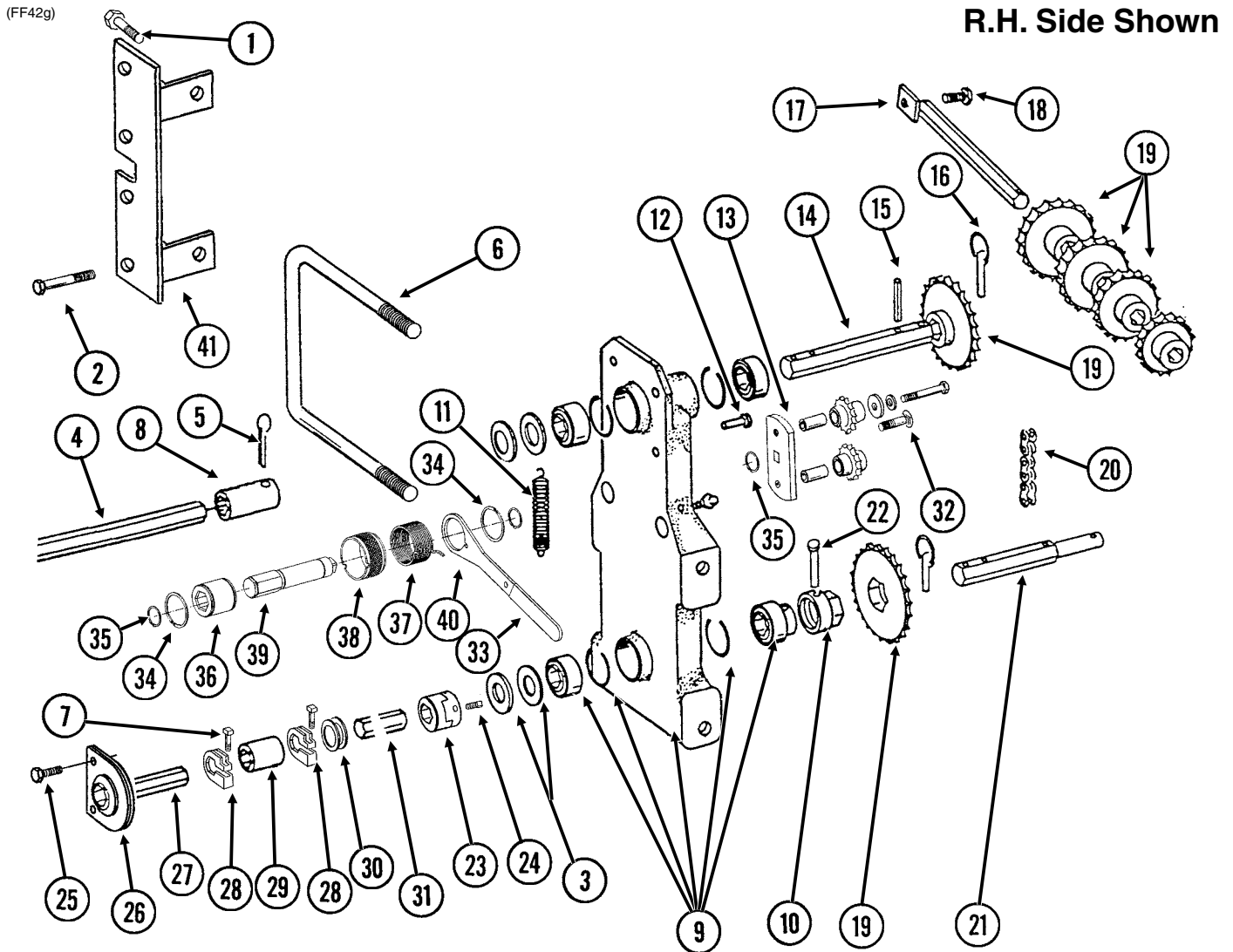

ITEM	PART NO.	QTY. (Per Assy.)	DESCRIPTION
1	G10008	2	Hex Head Cap Screw, 5/8"-11 x 2"
	G10230	2	Lock Washer, 5/8"
	G10104	2	Hex Nut, 5/8"-11
2	G10028	4	Hex Head Cap Screw, 3/4"-10 x 3"
	G10231	4	Lock Washer, 3/4"
	G11392	4	Flat Washer, 3/4" SAE
	G10105	2	Hex Nut, 3/4"-10
3	G10233	4	Machine Bushing, 1", 10 Gauge
4	---	-	<a href="#">See "Wheel Module Assembly" on page P107</a>
5	G10460	1	Cotter Pin, 1/4" x 2"
6	GD1114	1	U-Bolt, 7" x 7" x 5/8"-11
	G10107	2	Lock Nut, 5/8"-11
7	G10130	2	Square Head Machine Bolt, 5/16"-18 x 1 3/4"
	G10923	2	Flange Nut, 5/16"-18, No Serration
8	GD7867	1	Coupler, 3"
9	GA5629	1	Transmission Plate W/Bearings, Grease Fittings And Retaining Rings
	GA5116	3	Bearing, 7/8" Hex Bore, Cylindrical
	GA5624	1	Special Bearing, 7/8" Hex Bore x 1.6"
	GD6551	4	Ring
	G10640	-	Grease Fitting, 1/4"-28
10	GD7127	1	Shear Coupler

ITEM	PART NO.	QTY. (Per Assy.)	DESCRIPTION
11	GD5857	1	Spring
12	G10478	1	Clevis Pin, 5/16" x 1"
	G10409	1	Retaining Ring, 5/16"
13	GA7336	1	Idler W/Bolt-On Sprockets
	GD7426	-	Sprocket, 12 Tooth
	GD1026	-	Sleeve, 1 3/16" Long
	G11387	-	Flat Washer, 3/8" SAE
	G10229	-	Lock Washer, 3/8"
	G10047	-	Hex Head Cap Screw, 3/8"-16 x 1 3/4"
14	GD5835	1	Shaft, 7/8" x 7"
15	G10602	3	Spring Pin, 1/4" x 1 1/2"
16	GD2558	3	Lynch Pin, 1/4"
17	GA5146	1	Sprocket Storage Rod
18	G10017	1	Hex Head Cap Screw, 1/2"-13 x 1 1/2"
	G10228	1	Lock Washer, 1/2"
	G10102	1	Hex Nut, 1/2"-13
19	GA5106	1	Sprocket, 17 Tooth
	GA5107	1	Sprocket, 19 Tooth
	GA5108	2	Sprocket, 23 Tooth
	GA5109	1	Sprocket, 24 Tooth
	GA5110	1	Sprocket, 25 Tooth
	GA5111	1	Sprocket, 26 Tooth
	GA5112	1	Sprocket, 27 Tooth
	GA5113	1	Sprocket, 28 Tooth
20	G3310-80	1	Chain, No. 40, 80 Pitch Including Connector Link
	GR0912	-	Connector Link, No. 40
21	GD7822	1	Shaft, 7/8" x 7"
22	G10821	1	Clevis Pin, 3/16" x 2"
	G10455	1	Cotter Pin, 1/16" x 1/2"
23	GB0287	2	Coupler
24	G10131	4	Square Head Set Screw, 5/16"-18 x 3/4"
25	G10004	2	Hex Head Cap Screw, 3/8"-16 x 1 1/4"
	G10229	2	Lock Washer, 3/8"
	G10101	2	Hex Nut, 3/8"-16
26	GA2180	1	Hanger Bearing, 7/8" Hex Bore, 36 Row 20" Only
27	GD0914-152	1	Hex Shaft, 7/8" x 152" (No Holes)
28	GD11045	2	Lock Clamp
29	GD1719	1	Coupler, 4", 24 Row 30"
30	G10233	1	Machine Bushing, 1", 10 Gauge
31	GD0914-198	1	Hex Shaft, 7/8" x 198" (No Holes), R.H. And L.H. Sides, 24 Row 30"
	GD0914-208	-	Hex Shaft, 7/8" x 208" (No Holes), R.H. Side, 36 Row 20"
	GD0914-198	1	Hex Shaft, 7/8" x 198" (No Holes), L.H. Side, 36 Row 20"
32	G11100	1	Hex Socket Button Head Cap Screw, 1/4"-20 x 1/2", Grade 8
	G10227	1	Lock Washer, 1/4"
	G11385	1	Flat Washer, 1/4" SAE
33	G11078	1	Vinyl Cap
34	G10496	2	External Inverted Snap Ring, 1 1/2"
35	G11075	3	External Inverted Snap Ring, 7/8"
36	GD14432	1	Sleeve, 1 1/4"
37	GD14413	-	Torsion Spring, L.H. (Shown)
	GD14414	1	Torsion Spring, R.H.
38	GD19343	1	Release Collar, R.H.(Shown)
	GD19344	-	Release Collar, L.H.
39	GD14427	1	Tightener Shaft, 4 7/8"
40	GD14431	1	Handle
41	GA9524	-	Mount, 36 Row 20" Only (Shown)
A	G1K269	-	Lock Clamp Kit (Items 7 And 28)
B	G1K378	1	Wrap Spring Wrench Replacement Kit, Gold Collar, R.H. (Items 32-40)
	G1K379	-	Wrap Spring Wrench Replacement Kit, Silver Collar, L.H. (Items 32-40)

PTD016(TWL12)

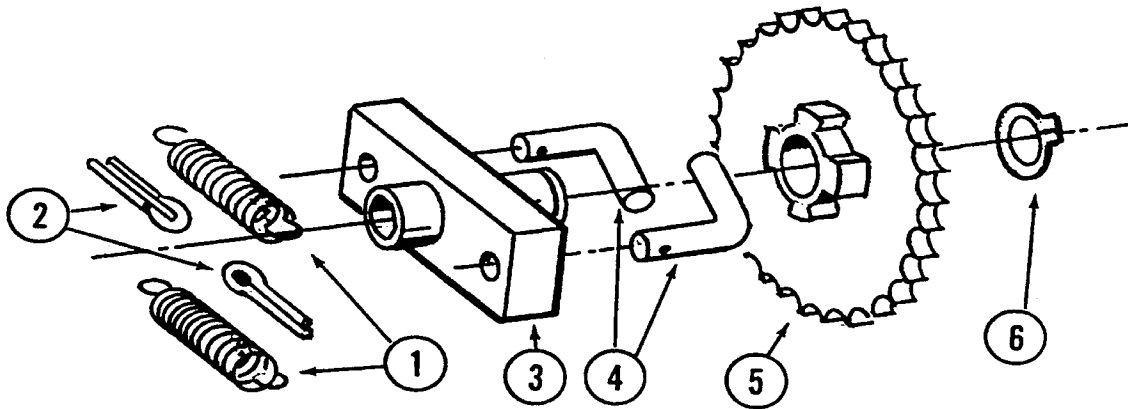

ITEM	PART NO.	QTY. (Per Assy.)	DESCRIPTION
1	GD1256	2	Spring
2	G10453	2	Cotter Pin, 3/16" x 1"
3	GA0378	1	Block And Hub Assembly
4	GD1255	2	L-Pin
5	GA5165	1	Sprocket, 30 Tooth
6	G10430	1	External Retaining Ring, 1 1/4"
A	GA5164	-	Ratchet/Sprocket Assembly (Items 1-6)

(IP1154/IP1177/A0542/A10458)

L.H. Side Shown

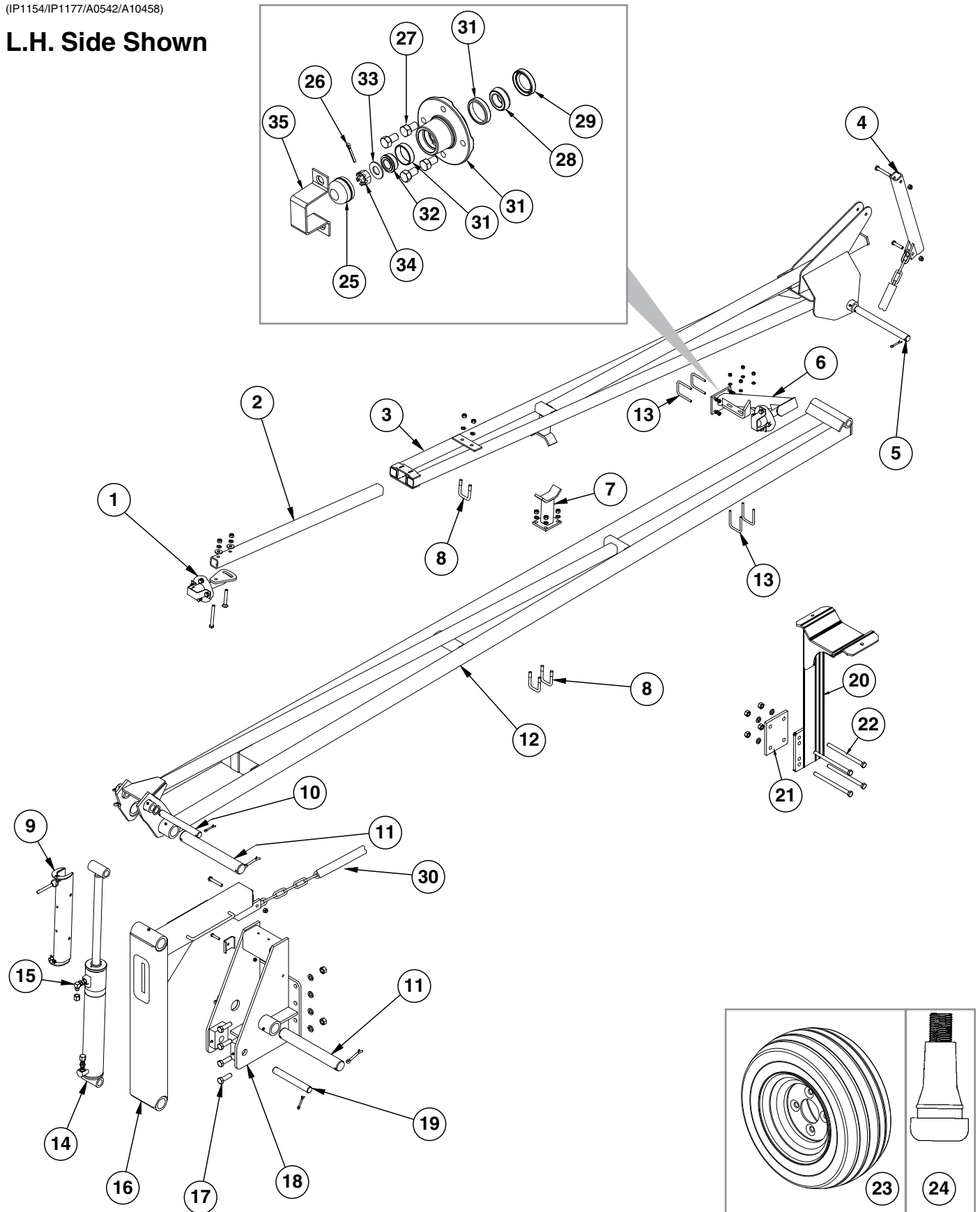

ITEM	PART NO.	QTY. (Per Assy.)	DESCRIPTION
1	---	1	<a href="#">See "Row Marker Spindle/Hub/Blade" on page P133</a>
2	GD0453-07	1	Extension Tube, 45"
3	GA9103	1	Arm W/Grease Fittings, Third Stage, 117", 24 Row 30" and 36 Row 20"
	GA12690	-	Arm W/Grease Fittings, Third Stage, 57", 24 Row 20"
	G10640	-	Grease Fitting, 1/4"-28
4	GA6860	1	Control Arm, 24 Row 30" and 36 Row 20"
	GA13485	-	Control Arm, 24 Row 20"
	G10581	1	Hex Head Cap Screw, 1/2"-13 x 2 1/4"
	G10111	3	Lock Nut, 1/2"-13
	G10033	1	Hex Head Cap Screw, 1/2"-13 x 3 1/2"
5	GD0704	1	Pin, 1 1/4" x 14"
	G10460	6	Cotter Pin, 1/4" x 2"
6	GA0160R	1	Support, R.H.
	GA0160L	-	Support, L.H. (Shown)
7	GA9101	1	Stop Weld, 24 Row 30" and 36 Row 20"
	GA12803	-	Stop Weld, 24 Row 20"
8	GD2721	3	U-Bolt, 2" x 2" x 1/2"-13
	G10228	2-6	Lock Washer, 1/2"
	G10102	2-6	Hex Nut, 1/2"-13
9	GA8172	1	Safety Lockup W/Detent Pins, 20"
	G10536	-	Detent Pin, 1/2" x 2 1/2" Grip
10	GD9964	1	Pin, 1 1/4" x 10 1/2"
	G10159	2	Washer, 1 7/8"
	G10460	2	Cotter Pin, 1/4" x 2"
11	GD0677	2	Pin, 2 1/8" x 15 3/4"
	G10461	4	Cotter Pin, 3/8" x 3"
12	GA9102	1	Arm W/Grease Fittings, Second Stage, 185", 24 Row 30" and 36 Row 20"
	GA12692	-	Arm W/Grease Fittings, Second Stage, 120", 24 Row 20"
	G10640	-	Grease Fitting, 1/4"-28
13	GD19212	4	U-Bolt, 2 1/2" x 3/8"-16
	G11387	4	Lock Washer, 3/8"
	G10108	4	Hex Nut, 3/8"-16
14	---	-	<a href="#">See "Row Marker (Cushion) Cylinder" on page P138</a>
15	G6801-08	1	Elbow W/O-Ring, 90°, 3/4"-16 Male JIC To O-Ring
	G6400-08	1	Connector W/O-Ring, 3/4"-16 Male JIC To O-Ring
	GR1037	-	O-Ring
	G304-C-8	2	Cap Nut, 3/4"-16
16	GA6870	1	Arm, First Stage
	G10038	1	Hex Head Cap Screw, 1/2"-13 x 3"
17	G10027	8	Hex Head Cap Screw, 3/4"-10 x 2 1/2"
	G10231	8	Lock Washer, 3/4"
	G10105	6	Hex Nut, 3/4"-10
18	GA4031	1	Mount W/Grease Fittings
	G10640	-	Grease Fitting, 1/4"-28
	GD5875	1	Hose Clamp, 9/16" x 2 1/2" x 2"
	G10108	1	Lock Nut, 3/8"-16
	G10047	1	Hex Head Cap Screw, 3/8"-16 x 1 3/4"
19	GD10186	1	Pin, 1 1/4" x 9 1/2"
	G10460	2	Cotter Pin, 1/4" x 2"
20	GA12434	1	Marker Tire Support
21	GD9622	1	Plate
22	G10152	4	Hex Head Cap Screw, 5/8"-11 x 9"
	G10104	4	Hex Nut, 5/8"-11
	G10230	4	Lock Washer, 5/8"

ITEM	PART NO.	QTY. (Per Assy.)	DESCRIPTION
23	GD0841	1	Tube Type Tire, 16" x 6.5" x 8" (Specify Brand*)
	GD1364	1	Tube (Not Shown)
	GA0246	1	Rim, T8 x 5.38" x 4
24	GA10458	1	Valve Stem
25	GD0840	1	Dust Cap
26	G10544	1	Cotter Pin, 5/32" x 1"
27	GD3248	4	Lug Bolt, 1/2"-20 x 1 1/4"
28	GA0245	1	Bearing
29	GD21540	1	Grease Seal
30	G3302-05	1	Coil Chain, No. 9/0, 79 Links, 24 Row 30" and 36 Row 20"
	G3302-11	-	Coil Chian, No. 9/0, 52 Links, 24 Row 20"
	GD10674-01	-	Nylon Cover, 141", 24 Row 30" and 36 Row 20"
	GD10674-04	-	Nylon Cover, 100", 24 Row 20"
31	GA0167	1	Hub W/Cups, 4 Bolt
	GR0151	-	Outer Cup
	GR0150	-	Inner Cup
	GB0165	-	Hub, 4 Bolt
32	GA0257	1	Bearing
33	G11391	1	Flat Washer, 5/8" SAE
34	G10725	1	Slotted Hex Nut, 5/8"-18
35	GD2597	1	Retainer
A	GA0542	1	Tire And Rim Assembly (Item 23)

**\*Specific brand requests will be supplied only as available from current Kinze Repair Parts stock. If a specific brand requested is not in stock, the brand available will be supplied.**

(IP1035a)

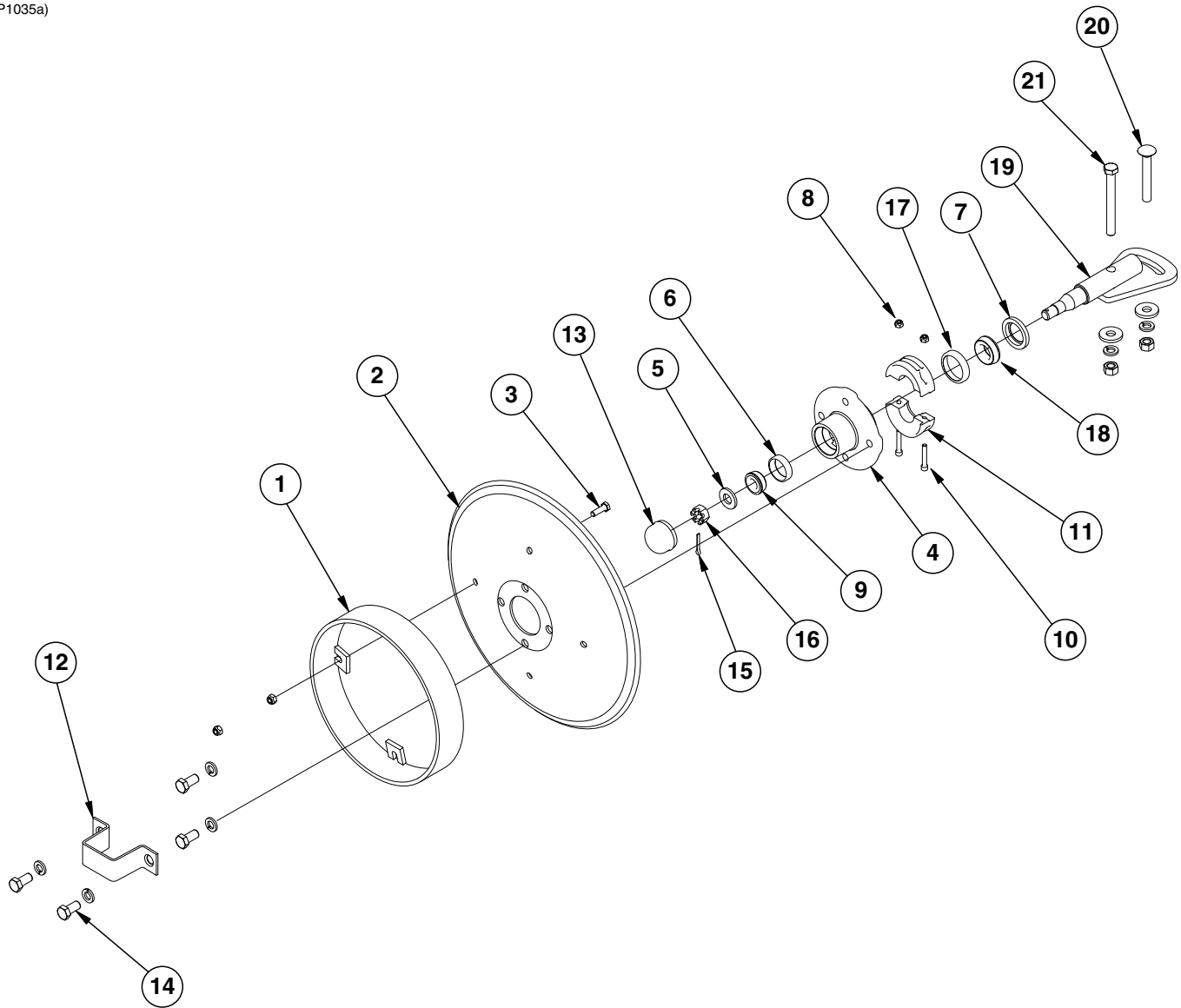

ITEM	PART NO.	QTY. (Per Assy.)	DESCRIPTION
1	GA5853	1	Depth Band
2	GD0746	1	Disc Blade, Solid, 16" (Shown)
	GD10283	-	Disc Blade, Notched, 16" (Optional)
3	G10019	4	Hex Head Cap Screw, 5/16"-18 x 1"
	G10109	4	Lock Nut, 5/16"-18, Grade 8
4	GA0167	1	Hub W/Cups, 4 Bolt (Includes Items 6 and 17)
5	G11391	1	Flat Washer, 5/8" SAE
6	GR0151	1	Outer Cup
7	GD21540	1	Grease Seal
8	G10110	2	Lock Nut, 1/4"-20, Grade B
9	GA0257	1	Bearing
10	G11418	2	Hex Socket Head Cap Screw, 1/4"-20 x 1 1/2"
11	GB0554	2	Hub Shield
12	GD2597	1	Retainer
13	GD0840	1	Dust Cap
14	G10722	4	Hex Head Cap Screw, 1/2"-20 x 1"
	G10228	4	Lock Washer, 1/2"
15	G10544	1	Cotter Pin, 5/32" x 1"
16	G10725	1	Slotted Hex Nut, 5/8"-18
17	GR0150	1	Inner Cup
18	GA0245	1	Bearing
19	GA15151	1	Spindle
20	G10844	1	Carriage Bolt, 1/2"-13 x 3 1/2"
	G10168	1	Machine Bushing, 1/2", 7 Gauge
	G10228	1	Lock Washer, 1/2"
	G10102	1	Hex Nut, 1/2"-13
21	G10045	1	Hex Head Cap Screw, 1/2"-13 x 4 1/2"
	G10168	2	Machine Bushing, 1/2", 7 Gauge
	G10228	2	Lock Washer, 1/2"
	G10102	2	Hex Nut, 1/2"-13
A	GA13719	-	Hub And Spindle Assembly, (Items 4-7, 9, and 12-19)

(CYL33d)

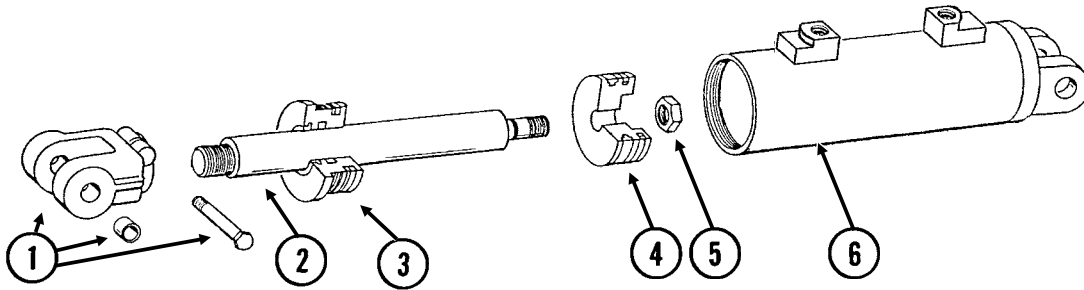

ITEM	PART NO.	QTY.	DESCRIPTION
1	GA8130	1	Clevis W/Bushings, Hex Head Cap Screw And Hex Nut
	GD11751	2	Steel Bushing, 1" Wide
	G10939	1	Hex Head Cap Screw, 3/8"-16 x 2 1/4"
	G10101	1	Hex Nut, 3/8"-16
2	GD12521	1	Rod
3	GD12522	1	Gland
4	GD12525	1	Piston
5	G10958	1	Lock Nut, 1"-14
6	A8927	1	Barrel <b>(Non-Stock Item)</b>
A	GA8928	-	Cylinder Complete, 4 1/2" x 10" <i>(Part Number Stamped On Barrel)</i>
B	GR1530	-	Seal Kit, Includes: (1) Wiper, (1) U-Cup, (2) O-Rings, (1) BU Ring, (2) Cast Iron Rings, (1) Seal, (1) Energizer

Slave Cylinders

CYL055(CYL15d)

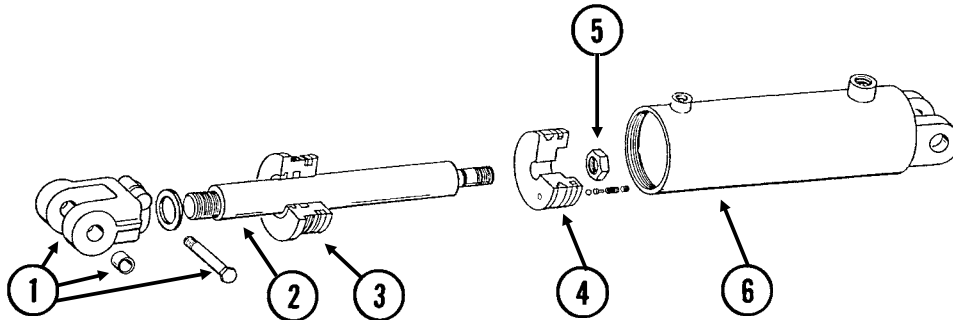

ITEM	PART NO.	QTY.	DESCRIPTION
1	GA8130	1	Clevis W/Bushings, Hex Head Cap Screw And Hex Nut
	GD11751	2	Steel Bushing, 1" Wide
	G10939	1	Hex Head Cap Screw, 3/8"-16 x 2 1/4"
	G10101	1	Hex Nut, 3/8"-16
2	GD12564	1	Rod
3	GD12572	1	Gland
4	GA8962	1	Piston W/Rephasing Valve
	GR1169	-	Rephasing Valve Replacement Kit (Set Screw, Guide, 2 Springs And Ball)
5	G10958	1	Lock Nut, 1"-14
6	A8960	1	Barrel <b>(Non-Stock Item)</b>
A	GA8961	-	Cylinder Complete, 4 3/4" x 20" <i>(Part Number Stamped On Barrel)</i>
B	GR1546	-	Seal Kit, Includes: (1) Wiper, (1) U-Cup, (2) O-Rings, (1) BU Ring, (2) Cast Iron Rings, (1) Seal, (1) Energizer

(IP1301)

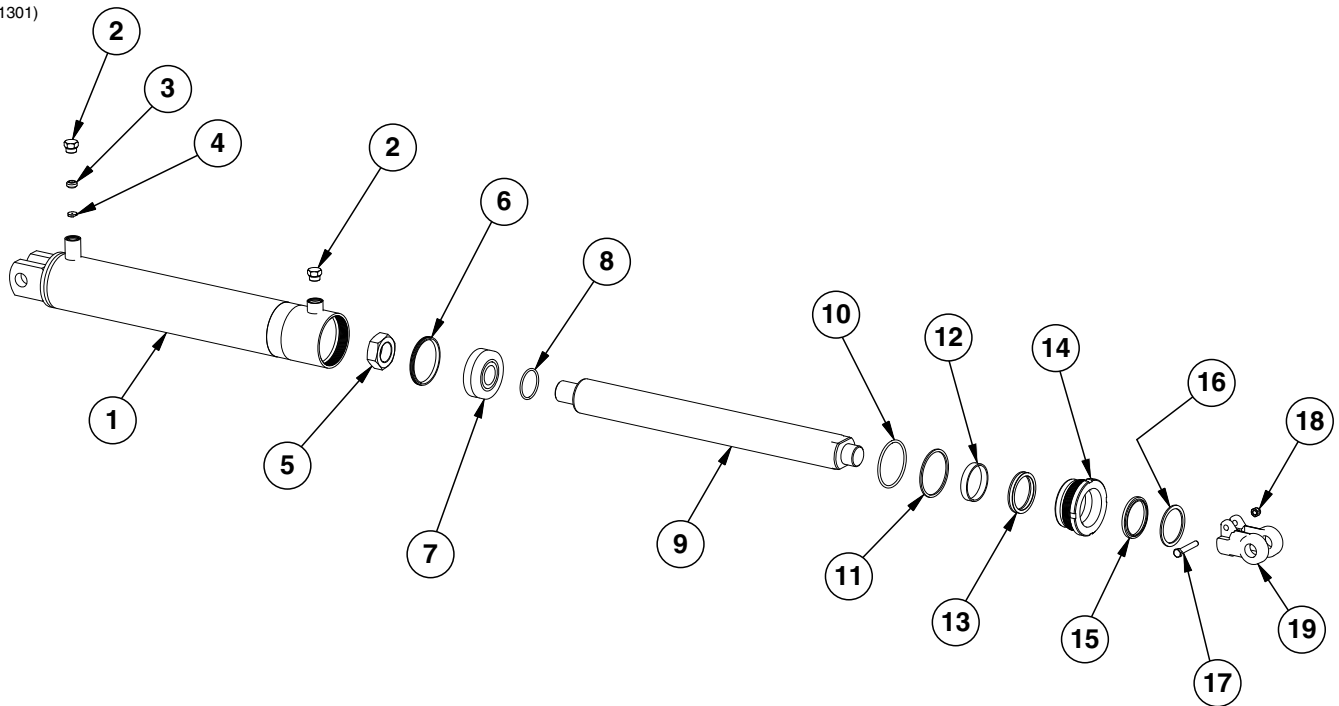

ITEM	PART NO.	QTY.	DESCRIPTION
1	A8969	1	Barrel (Non-Stock Item)
2	G6408-08	2	Plug W/O-Ring, 3/4"-16 O-Ring
3	G10987	1	Hollow Lock Screw, 3/4"-16 x 3/8"
4	GD12589	1	Orifice Plate
5	G10087	1	Hex Jam Nut, 1 1/2"-12, Grade 2
6	*D12280	1	T-Seal
7	GD20991	1	Piston
8	*D20990	1	O-Ring
9	GD20989	1	Rod
10	*D12231	1	O-Ring
11	*D12232	1	Backup Ring
12	*D12137	1	Wear Ring
13	*D12264	1	U-Cup
14	GD20988	1	Gland
15	*D12263	1	Wiper
16	*D12121	1	Ring
17	G10939	1	Hex Head Cap Screw, 3/8"-16 x 2 1/4"
18	G10108	1	Lock Nut, 3/8"-16
19	GD11951	1	Clevis
A	GA14697	-	Cylinder Complete, 3 1/2" x 20" (Part Number Stamped On Barrel)
B	GR1962	1	Seal Kit, Includes: (1) Wiper, (1) U-Cup, (2) O-Rings, (1) Backup Ring, (1) T-Seal, (1) Wear Ring, (1) Ring

\*Item is part of seal kit, item can not be purchased individually.

(CYL33d)

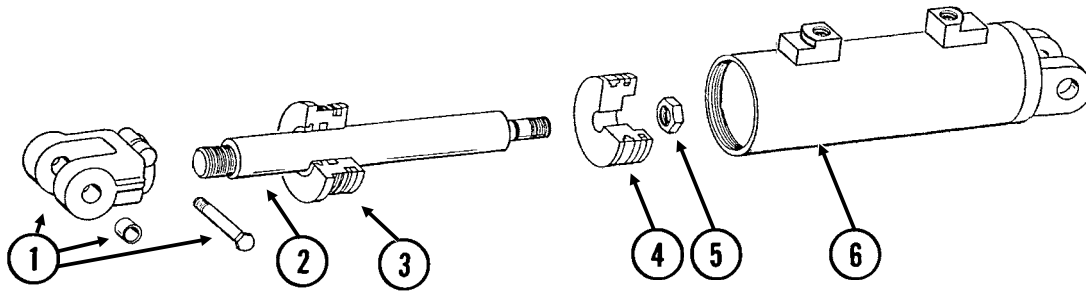

ITEM	PART NO.	QTY.	DESCRIPTION
1	GA8130 GD11751 G10939 G10101	1 2 1 1	Clevis W/Bushings, Hex Head Cap Screw And Hex Nut Steel Bushing, 1" Wide Hex Head Cap Screw, 3/8"-16 x 2 1/4" Hex Nut, 3/8"-16
2	GD16202	1	Rod
3	GD11984	1	Gland
4	GD16200	1	Piston
5	G10958	1	Lock Nut, 1"-14
6	A11072	1	Barrel ( <b>Non-Stock Item</b> )
A	GA11073	-	Cylinder Complete, 3" x 10" ( <i>Part Number Stamped On Barrel</i> )
B	GR1740	-	Seal Kit, Includes: (1) Wiper, (1) U-Cup, (2) O-Rings, (1) BU Ring, (2) Cast Iron Rings, (1) Seal, (1) Energizer

(IP1167)

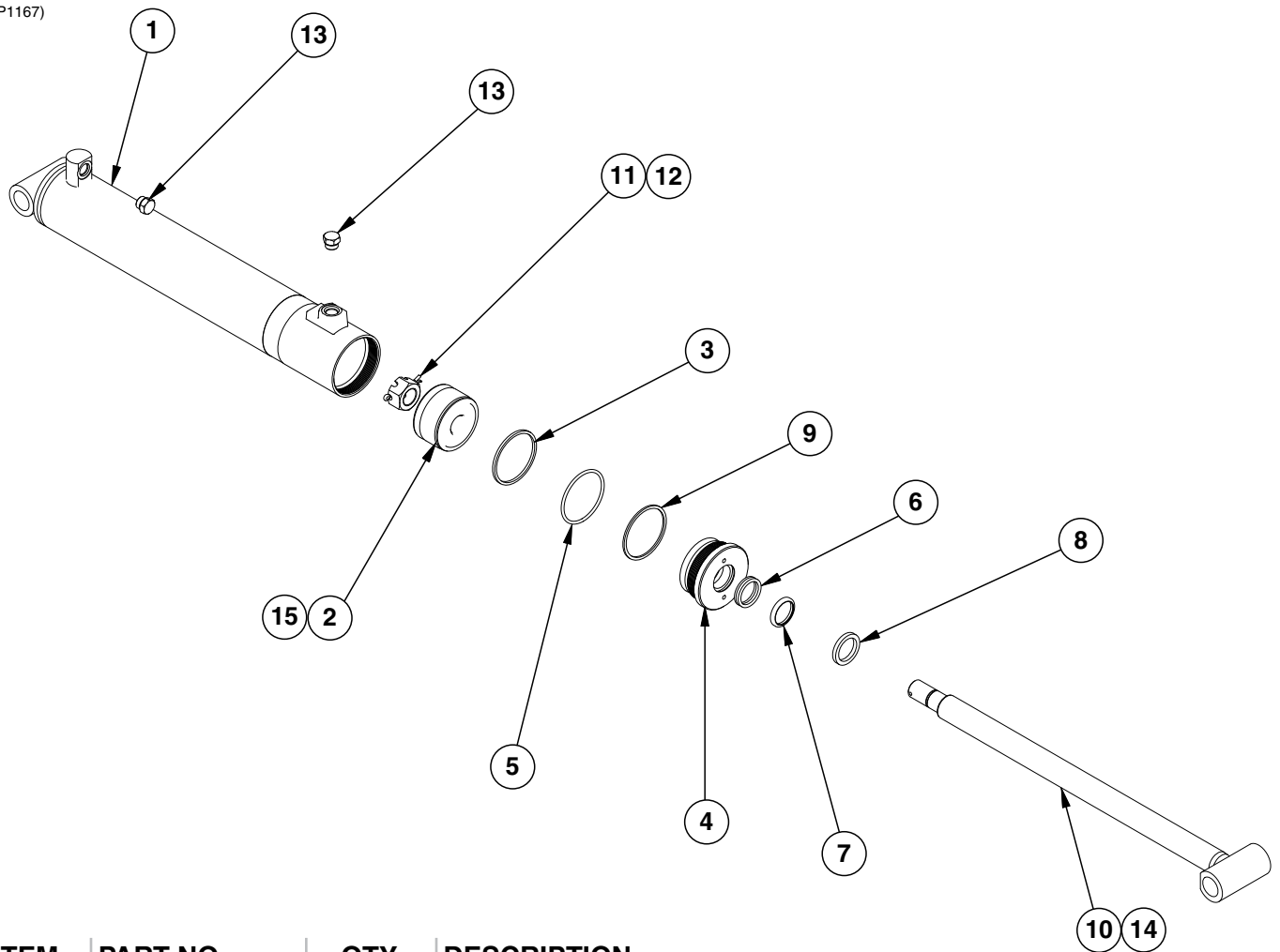

ITEM	PART NO.	QTY.	DESCRIPTION
1	A8950	1	Barrel (Non-Stock Item)
2	GD12550	1	Piston, 3½"
3	*D12088	1	Piston Ring
4	GD12548	1	Gland
5	GD12231	1	O-Ring, No. 338
6	*D12252	1	U-Cup
7	*D12206	1	Wiper
8	GD12103	1	Ring
9	*D12232	1	Back-up Ring
10	GA8948	1	Rod Assembly
11	G10983	1	Slotted Hex Nut, 1⅞"-12
12	G10984	1	Cotter Pin, ⅜" x 2½"
13	G6408-08	2	Plug W/O-Ring, ¾"-16 O-Ring
	GR1037	-	O-Ring
14	*D12245	1	O-Ring, #122
15	*D12280	1	T-Seal
A	GA8951	-	Cylinder Complete, 3½" x 20" (Part Number Stamped On Barrel)
B	GR1532	-	Seal Kit, Includes: (2) O-Rings, (1) U-Cup, (1) Wiper, (1) T-Seal, (1) BU Ring, (1) Cast Iron Ring

\*Item is part of seal kit, item can not be purchased individually.

(CYL17a)

**R.H. Side Only**

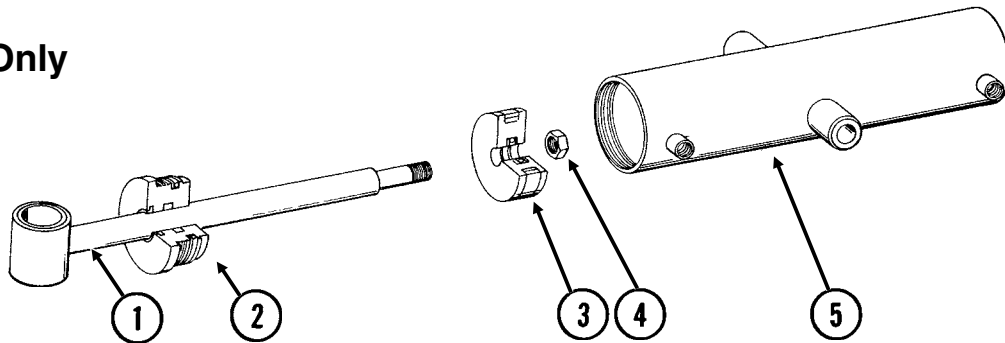

ITEM	PART NO.	QTY.	DESCRIPTION
1	GA8910 G10640	1 -	Rod Assembly W/Grease Fitting Grease Fitting, 1/4"-28
2	GD11988	1	Gland
3	GD11997	1	Piston
4	G10958	1	Lock Nut, 1"-14
5	A8300	1	Barrel ( <b>Non-Stock Item</b> )
A	GA8906	-	Cylinder Complete, 4" x 13 5/8" ( <i>Part Number Stamped On Barrel</i> )
B	GR1525	-	Seal Kit, Includes: (2) O-Rings, (1) BU Ring, (1) U-Cup, (1) Wiper, (1) T-Seal

**Helper Cylinder, All Sizes**

CYL055(CYL17a)

**L.H. Side Only**

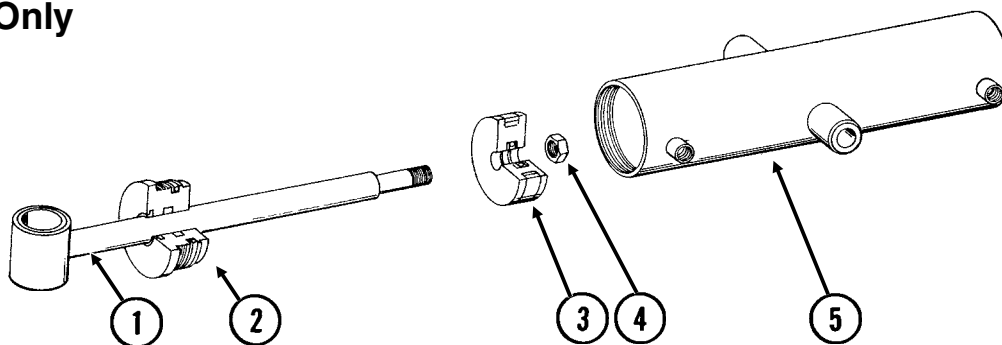

ITEM	PART NO.	QTY.	DESCRIPTION
1	GA8907 G10640	1 -	Rod Assembly W/Grease Fitting Grease Fitting, 1/4"-28
2	GD11988	1	Gland
3	GD11997	1	Piston
4	G10958	1	Lock Nut, 1"-14
5	A6852	1	Barrel ( <b>Non-Stock Item</b> )
A	GA8905	-	Cylinder Complete, 4" x 15 5/32" ( <i>Part Number Stamped On Barrel</i> )
B	GR1525	-	Seal Kit, Includes: (2) O-Rings, (1) BU Ring, (1) U-Cup, (1) Wiper, (1) T-Seal

(CYL18b)

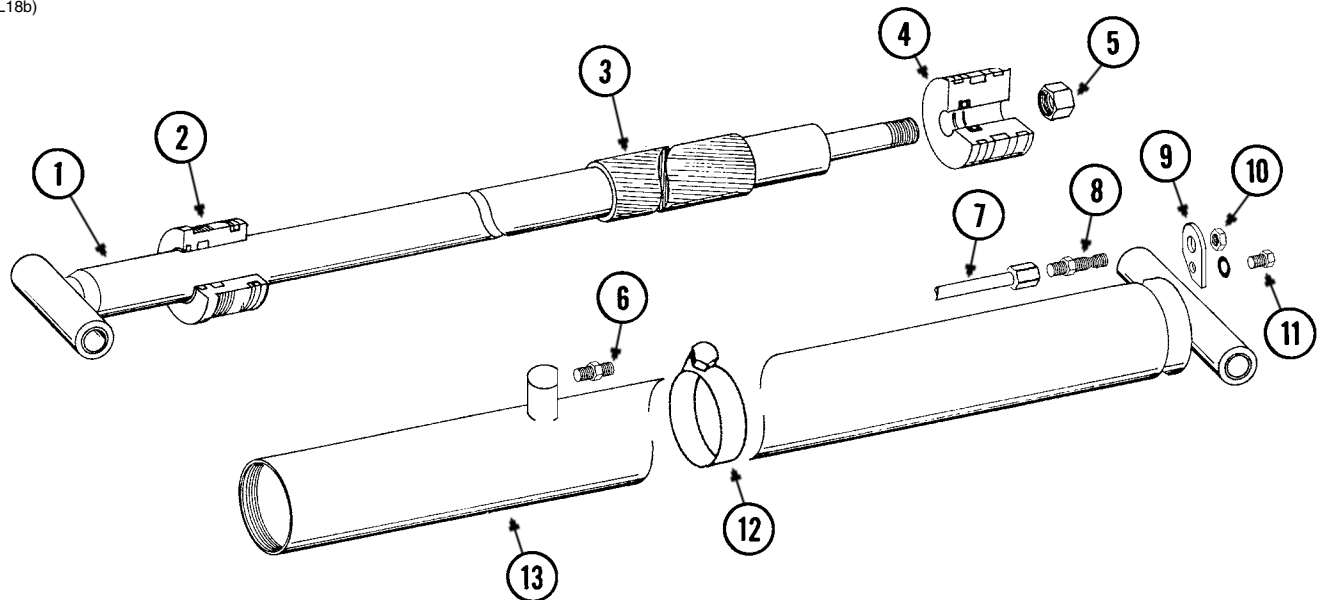

ITEM	PART NO.	QTY.	DESCRIPTION
1	GA9576	1	Rod Assembly
2	GD13448	1	Gland
3	GD13453	1	Spacer
4	GD13449	1	Piston
5	G10972	1	Lock Nut, 1¼"-12
6	G6400-08-04 GR1465	1 -	Connector W/O-Ring, ¾"-16 Male JIC To 7/16"-20 O-Ring O-Ring
7	GA10145	1	Steel Hydraulic Line, 145 <sup>15</sup> / <sub>16</sub> "
8	G2700-08	1	Bulkhead Tube Union, ¾"-16 Male JIC
9	GD13643	1	Bracket
10	G306-08	1	Lock Nut, ¾"-16
11	G10328 G10229	1 1	Hex Head Cap Screw, 3/8"-16 x 5/8" Lock Washer, 3/8"
12	G11089	1	Hose Clamp
13	GA9578	1	Barrel
A	GA9579	-	Cylinder Complete, 4" x 132½" (Part Number Stamped On Barrel)
B	GR1599	-	Seal Kit, Includes: (2) O-Rings, (1) BU Ring, (3) Wear Rings, (1) Piston Seal, (1) U-Cup, (1) Wiper, (1) Expander

(IP1166)

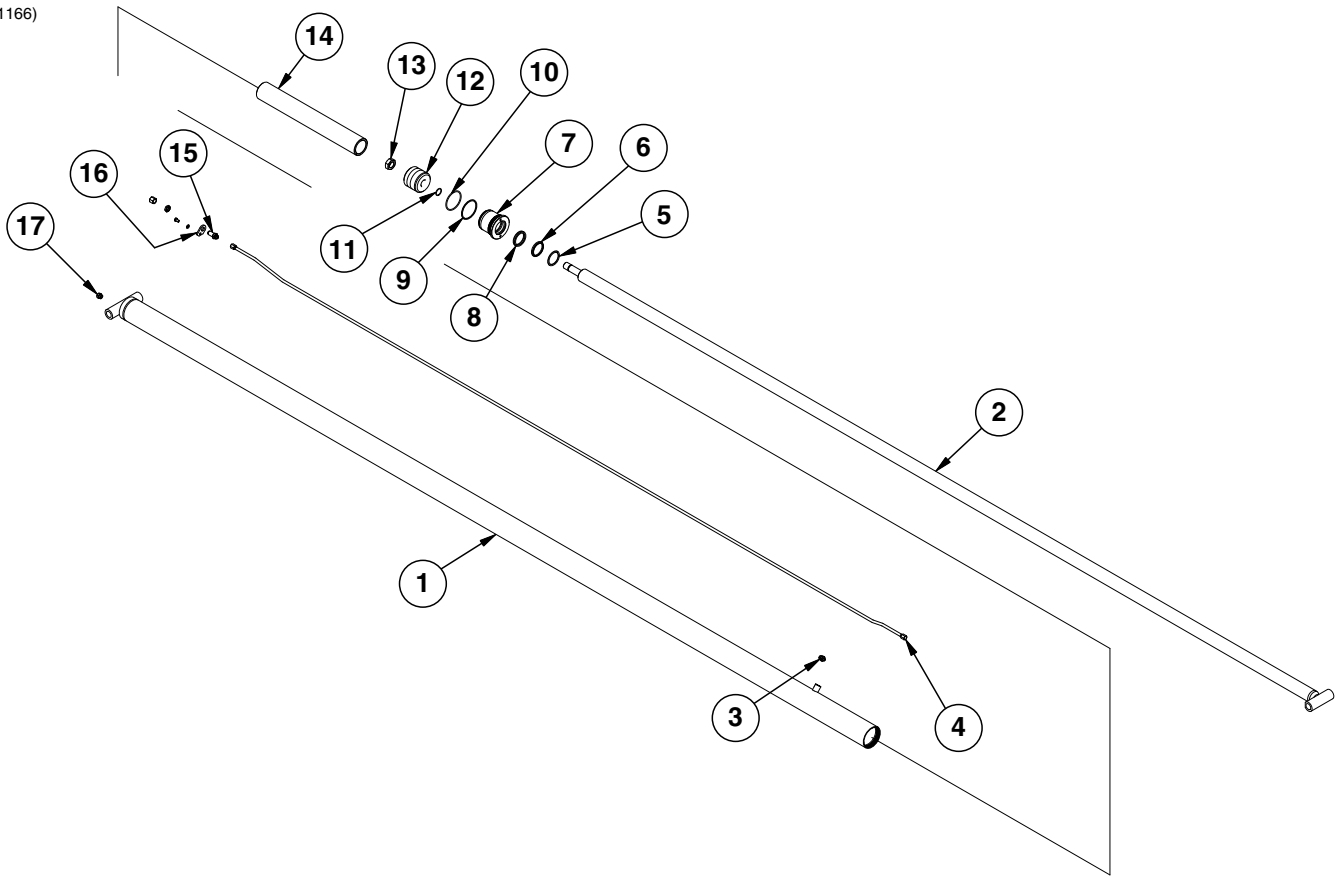

ITEM	PART NO.	QTY.	DESCRIPTION
1	A9582	1	Barrel (Non-Stock Item)
2	GA9580	1	Rod Assembly
3	G6400-08-04 GR1465	1 -	Connector W/O-Ring, 3/4"-16 Male JIC To 7/16"-20 O-Ring O-Ring
4	GA10146 G11089	1 1	Steel Hydraulic Line, 178 1/4" Hose Clamp
5	GD12121	1	Ring, 2 1/2"
6	*D12263	1	Wiper Rod
7	GD13448 GD12137	1 1	Gland Wear Ring
8	*D12264	1	U-Cup
9	*D12222	1	Back-Up Ring No. 342
10	*D12221	1	O-Ring, No. 342
11	*D12204	1	O-Ring, No. 218
12	GD13449 *D12265 *D12120 *D12119	1 1 2 1	Piston Expander Wear Ring Piston Seal
13	G10972	1	Lock Nut, 1 1/4"-12
14	GD13456	1	Spacer
15	G2700-08 G306-08 G304-C-8	1 1 1	Bulkhead Tube Union, 3/4"-16 Male JIC Lock Nut, 3/4"-16 Cap Nut, 3/4"-16
16	GD13643 G10328 G10229	1 1 1	Bracket Hex Head Cap Screw, 3/8"-16 x 5/8" Lock Washer, 3/8"
17	G6408-08 GR1037	1 1	Plug W/O-Ring, 3/4"-16 O-Ring O-Ring
A	GA9583	-	Cylinder Complete, 4" x 162" (Part Number Stamped On Barrel)
B	GR1599	-	Seal Kit, Includes: (2) O-Rings, (1) BU Ring, (3) Wear Rings, (1) Piston Seal, (1) U-Cup, (1) Wiper, (1) Expander

\*Item is part of seal kit, item can not be purchased individually.

(FF19c)

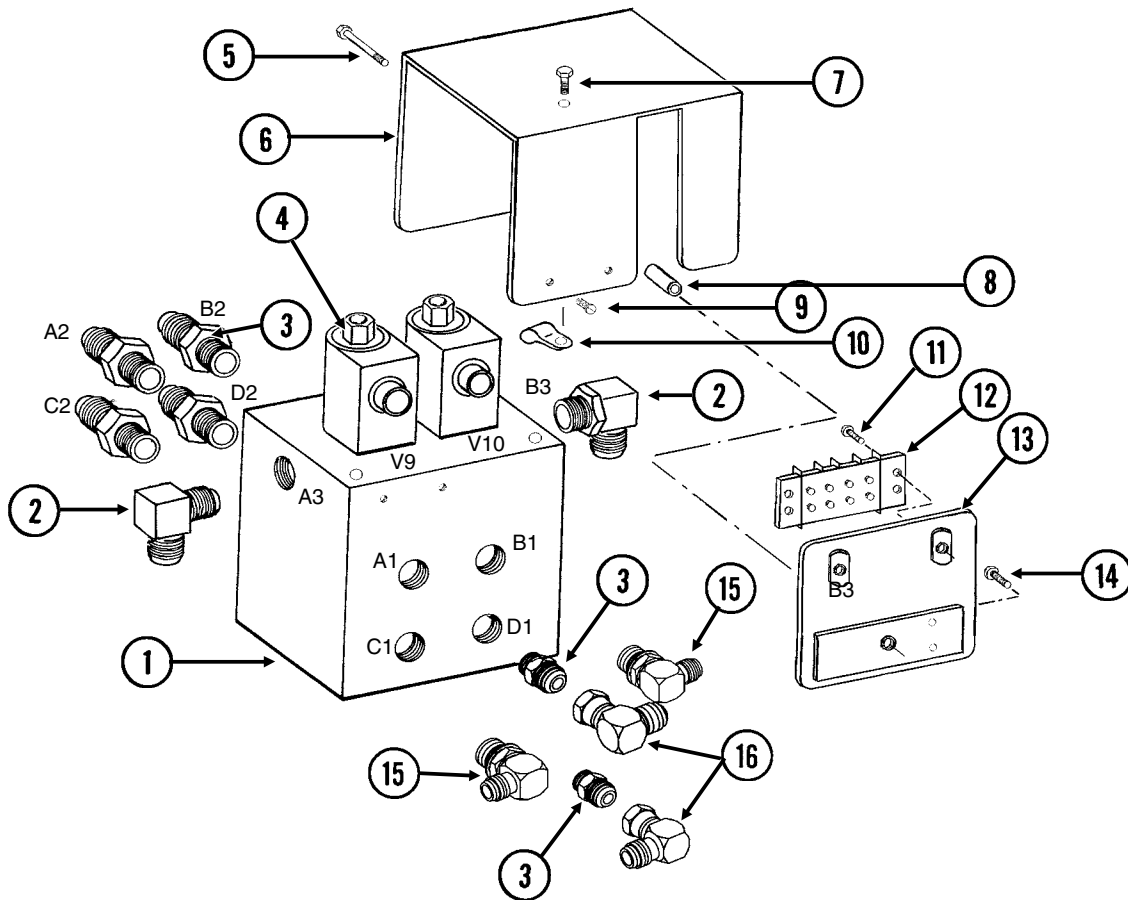

ITEM	PART NO.	QTY.	DESCRIPTION
1	GD9531	1	Block
2	G6801-08 GR1037	2 -	Elbow W/O-Ring, 90°, 3/4"-16 Male JIC To O-Ring O-Ring
3	G6400-10-08 GR1037	6 -	Connector W/O-Ring, 7/8"-14 Male JIC To 3/4"-16 O-Ring O-Ring
4	---	-	<a href="#">See "Solenoid Valve (G1K276)" on page P152</a>
5	G10133 G10232	1 1	Hex Head Cap Screw, 5/16"-18 x 1 1/2" Lock Washer, 5/16"
6	GD13365	1	Cover
7	G10054 G10232 G10106	1 1 1	Hex Head Cap Screw, 5/16"-18 x 1/2" Lock Washer, 5/16" Hex Nut, 5/16"-18
8	GD8066-02	1	Sleeve, 1" Long
9	G10977	2	Phillips Pan Head Machine Screw, No. 10-24 x 1/2", Stainless Steel
10	GD13348	1	Insulated Clamp, 1 1/16"
11	G11067	2	Phillips Pan Head Machine Screw, No. 8-32 x 3/4", Stainless Steel
12	GA9510 GR1635	1 -	Terminal Strip W/Screws, No. 6, 4 Terminal Screw, No. 6-32 x 1/4"
13	GA9518	1	Terminal Strip Mount
14	G11066	2	Phillips Pan Head Machine Screw, No. 10-24 x 3/4", Stainless Steel
15	G6801-10-08 GR1037	2 -	Elbow W/O-Ring, 90°, 7/8"-14 Male JIC To 3/4"-16 O-Ring O-Ring
16	G6500-10	2	Swivel Elbow, 90°, 7/8"-14 Male JIC To Female

(FF20a)

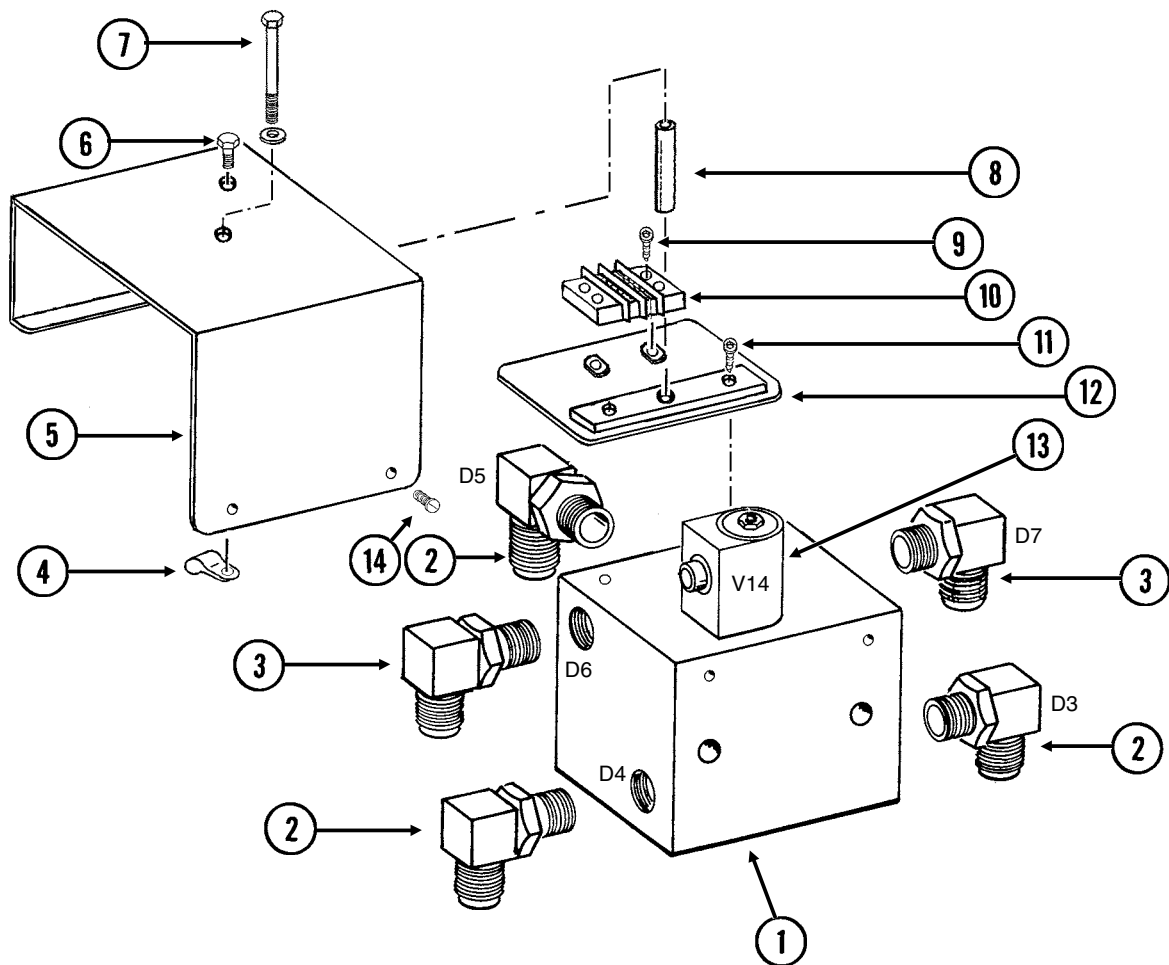

ITEM	PART NO.	QTY.	DESCRIPTION
1	GD9536	1	Block
2	G6801-10-08 GR1037	3 -	Elbow W/O-Ring, 90°, 7/8"-14 Male JIC To 3/4"-16 O-Ring O-Ring
3	G6801-08 GR1037	2 -	Elbow W/O-Ring, 90°, 3/4"-16 Male JIC To O-Ring O-Ring
4	GD13348	1	Insulated Clamp, 1 1/16"
5	GD13366	1	Cover
6	G10054 G10232 G10106	1 1 1	Hex Head Cap Screw, 5/16"-18 x 1/2" Lock Washer, 5/16" Hex Nut, 5/16"-18
7	G10583 G10232	1 1	Hex Head Cap Screw, 5/16"-18 x 2 3/4" Lock Washer, 5/16"
8	GD8066-03	1	Sleeve, 2 5/16" Long
9	G11067	2	Phillips Pan Head Machine Screw, No. 8-32 x 3/4", Stainless Steel
10	GA9511 GR1635	1 -	Terminal Strip W/Screws, No. 6, 2 Terminal Screw, No. 6-32 x 1/4"
11	G11066	2	Phillips Pan Head Machine Screw, No. 10-24 x 3/4", Stainless Steel
12	GA9519	1	Terminal Strip Mount
13	---	-	<a href="#">See "Solenoid Valve (G1K275)" on page P152</a>
14	G10977	2	Phillips Pan Head Machine Screw, No. 10-24 x 1/2", Stainless Steel

(FF21a)

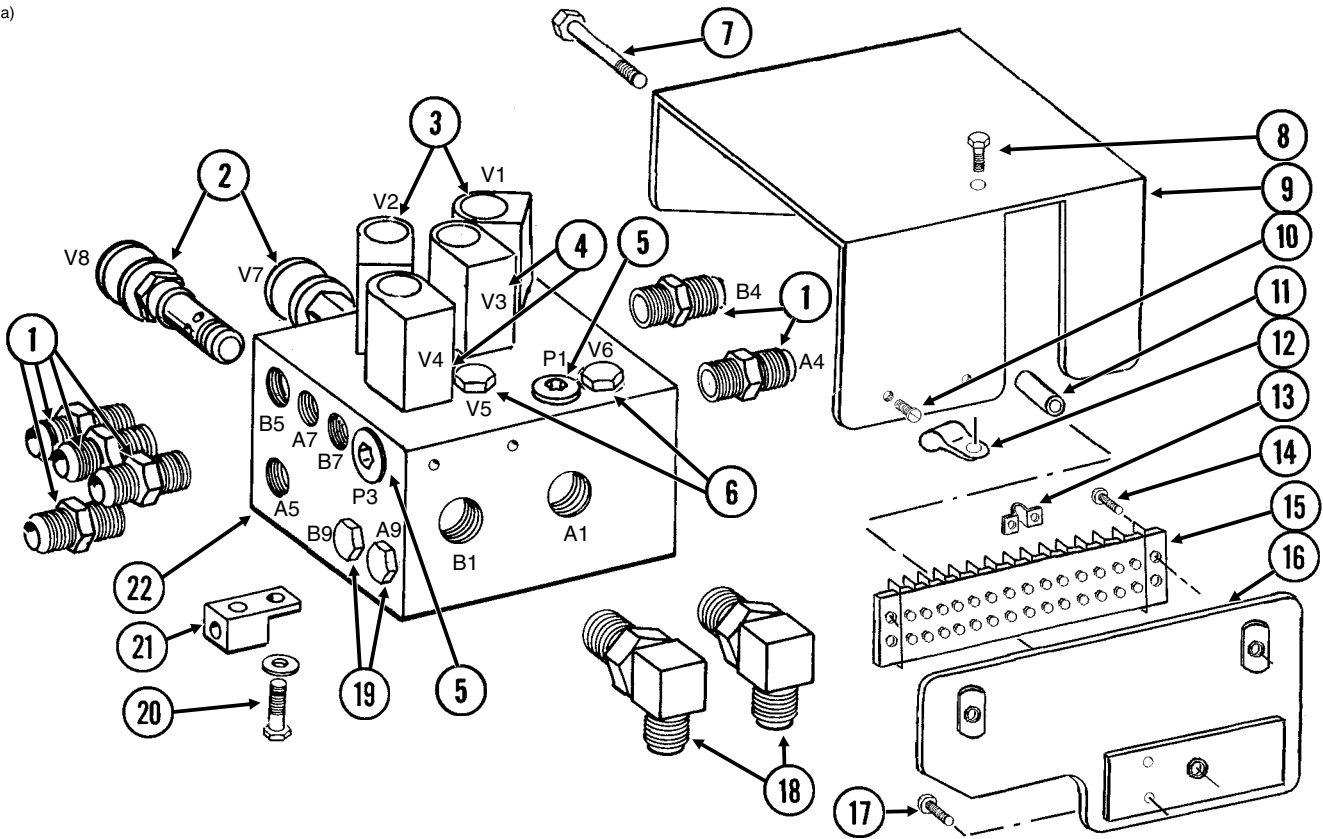

ITEM	PART NO.	QTY.	DESCRIPTION
1	G6400-08 GR1037	6 -	Connector W/O-Ring, 3/4"-16 Male JIC To O-Ring O-Ring
2	---	-	<a href="#">See "Flow Control Valve" on page P153</a>
3	---	-	<a href="#">See "Solenoid Valve (G1K275)" on page P152</a>
4	---	-	<a href="#">See "Solenoid Valve (G1K276)" on page P152</a>
5	G6408-H06-O GR1045	5 -	Hex Socket Head Plug W/O-Ring, 9/16"-18 O-Ring O-Ring
6	G6408-10 GR1466	2 -	Plug W/O-Ring, 7/8"-14 O-Ring O-Ring
7	G10003 G10229	1 2	Hex Head Cap Screw, 3/8"-16 x 1 1/2" Lock Washer, 3/8"
8	G10004 G11091	1 1	Hex Head Cap Screw, 3/8"-16 x 1 1/4" Serrated Flange Nut, 3/8"-16
9	GD13146	1	Cover
10	G10977	2	Phillips Pan Head Machine Screw, No. 10-24 x 1/2", Stainless Steel
11	GD7318	1	Sleeve, 1" Long
12	GD13348	1	Insulated Clamp, 1 1/16"
13	GD13310	1	Jumper, 7/16"
14	G11067	2	Phillips Pan Head Machine Screw, No. 8-32 x 3/4", Stainless Steel
15	GA9097 GR1635	1 -	Terminal Strip W/Screws, No. 6, 14 Terminal Screw, No. 6-32 x 1/4"
16	GA13741	1	Terminal Strip, Mount
17	G11066	2	Phillips Pan Head Machine Screw, No. 10-24 x 3/4", Stainless Steel
18	G6801-10 GR1466	2 -	Elbow W/O-Ring, 90°, 7/8"-14 Male JIC To O-Ring O-Ring
19	G6408-08 GR1037	6 -	Plug W/O-Ring, 3/4"-16 O-Ring O-Ring
20	G10019 G10043 G10232 G11386	1 1 2 -	Hex Head Cap Screw, 5/16"-18 x 1" Hex Head Cap Screw, 5/16"-18 x 3/4" Lock Washer, 5/16" Flat Washer, 5/16" SAE
21	GA3584	1	Ground Clamp
22	GD9533	1	Block

VVB030(F22c)

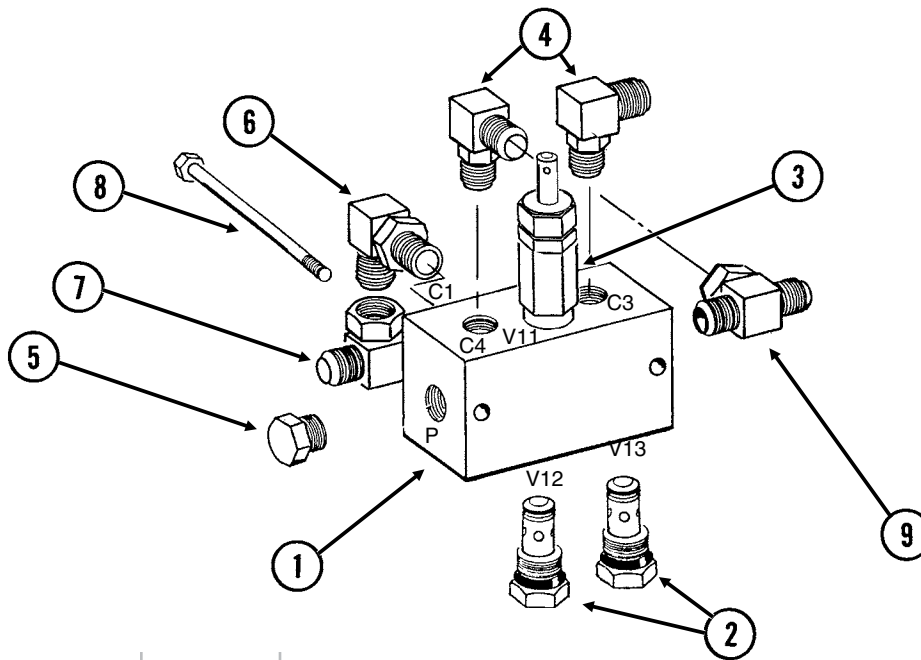

ITEM	PART NO.	QTY.	DESCRIPTION
1	GD9535	1	Block
2	---	-	<a href="#">See "Check Valve" on page P153</a>
3	---	-	<a href="#">See "Pressure Relief Valves" on page P153</a>
4	G6801-08 GR1037	2 -	Elbow W/O-Ring, 90°, 3/4"-16 Male JIC To O-Ring O-Ring
5	G6408-06 GR1045	1 -	Plug W/O-Ring, 9/16"-18 O-Ring O-Ring
6	G6801-10-08 GR1037	1 -	Elbow W/O-Ring, 90°, 7/8"-14 Male JIC To 3/4"-16 O-Ring O-Ring
7	G6600-10	1	Swivel Tee, 7/8"-14 JIC
8	G10746 G10227 G10103	2 2 2	Hex Head Cap Screw, 1/4"-20 x 2 3/4" Lock Washer, 1/4" Hex Nut, 1/4"-20
9	G6600-08	1	Swivel Tee, 3/4"-16 JIC

(FF103)

**36 Row 20" Only**

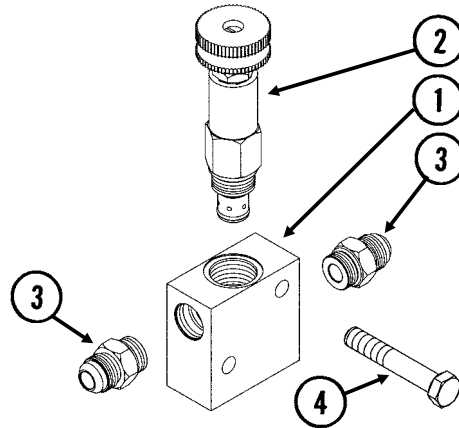

ITEM	PART NO.	QTY.	DESCRIPTION
1	GA12113	1	Block
2	---	-	<a href="#">See "Pressure Relief Valves" on page P153</a>
3	G6400-08	1	Connector W/O-Ring, 3/4"-16 Male JIC To O-Ring
4	G10939	2	Hex Head Cap Screw, 3/8"-16 x 2 1/4"
	G10229	2	Lock Washer, 3/8"
	G10101	2	Hex Nut, 3/8"-16

**Pilot Pressure Booster Valve Block**

(IP1185)

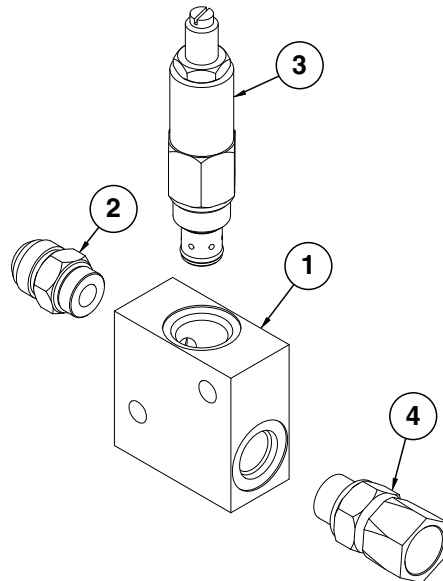

ITEM	PART NO.	QTY.	DESCRIPTION
1	GD14528	1	Valve Block
2	G6400-10-08	1	Connector W/O-Ring, 7/8"-14 Male JIC To 3/4"-16 O-Ring
	GR1037	-	O-Ring
3	GA3407	1	Pressure Relief Valve, 1000 PSI
4	G6402-08-10	1	Connector W/O-Ring, 7/8"-14 Female JIC to 3/4"-16 O-Ring

(IP1157)

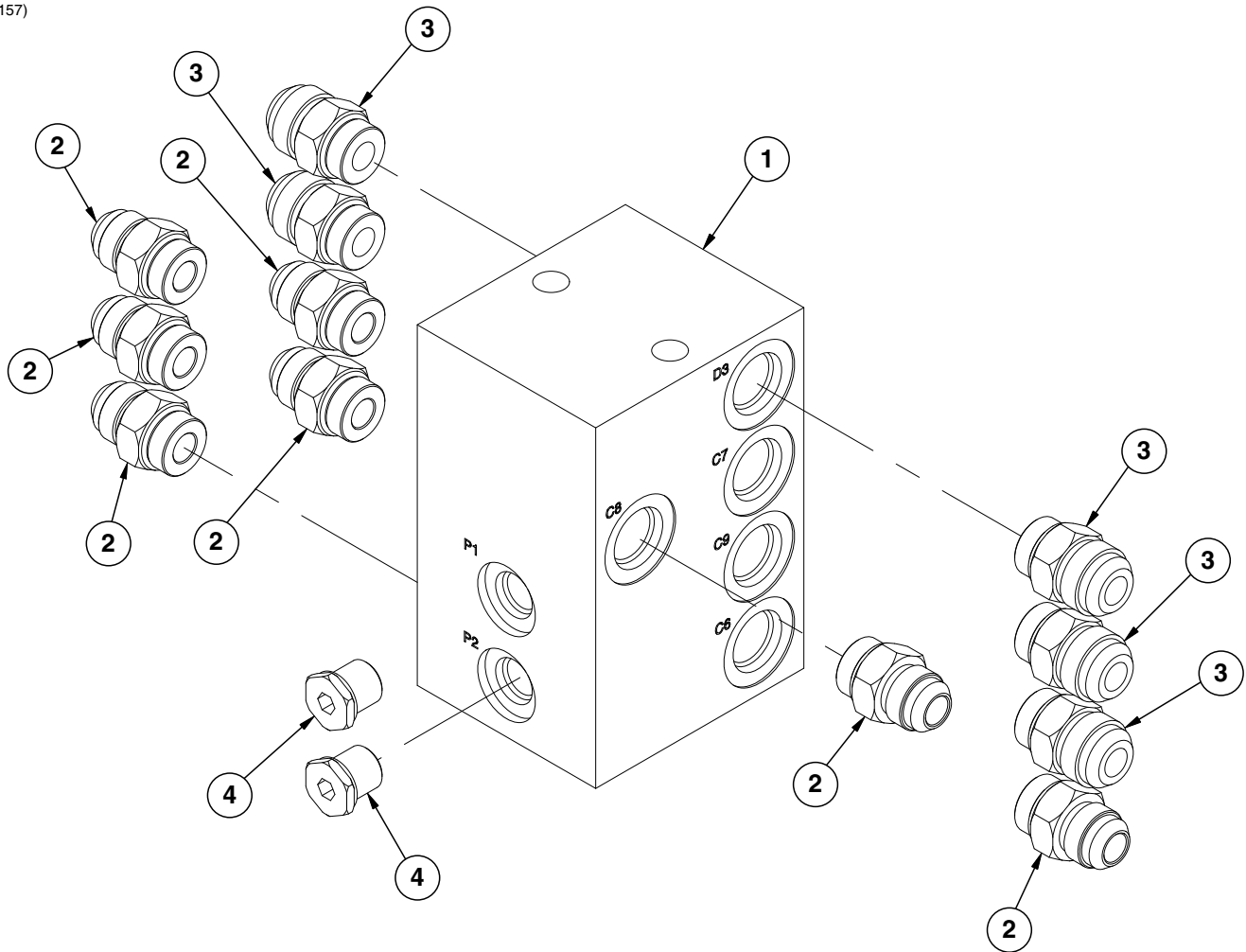

ITEM	PART NO.	QTY.	DESCRIPTION
1	GD9537	1	Junction Block
2	G6400-08 GR1037	7 -	Connector W/O-Ring, 3/4"-16 Male JIC To O-Ring O-Ring
3	G6400-10-08 GR1037	5 -	Connector W/O-Ring, 7/8"-14 Male JIC To 3/4"-16 O-Ring O-Ring
4	G6408-H06-0	2	Hex Socket O-Ring Plug, 9/16"-12

VVB038(HYD31a)

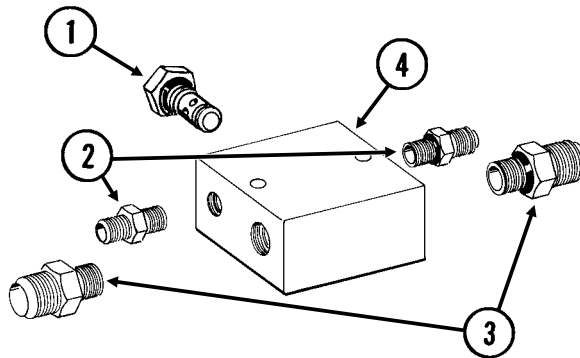

ITEM	PART NO.	QTY.	DESCRIPTION
1	---	-	<a href="#">See "Check Valve" on page P153</a>
2	G6400-04 GR1465	2 -	Connector W/O-Ring, 7/16"-20 Male JIC To O-Ring O-Ring
3	G6400-10 GR1466	2 -	Connector W/O-Ring, 7/8"-14 Male JIC To O-Ring O-Ring
4	GD13447	1	Block

**Detent Lever Valve**

VVB033(FF24)

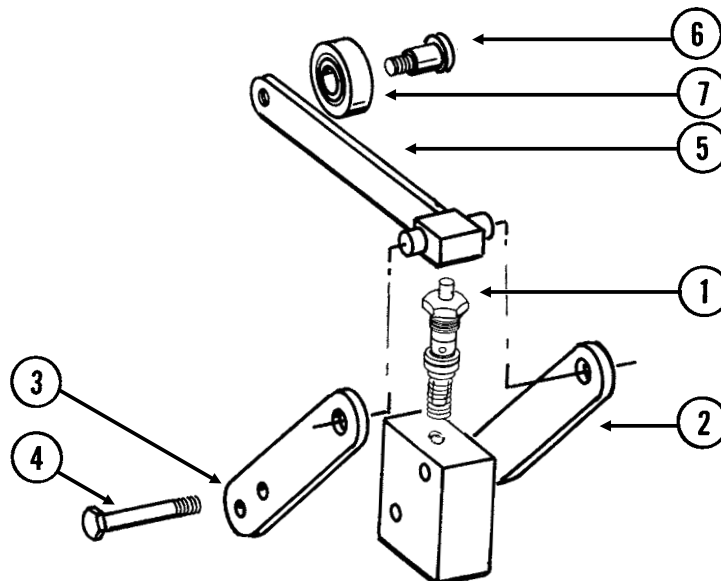

ITEM	PART NO.	QTY.	DESCRIPTION
1	GR1254	1	Valve
2	GR1259	1	Bar
3	GR1255	1	Bar
4	G10060 G11387 G10106	2 2 2	Hex Head Cap Screw, 5/16"-18 x 2 1/2" Flat Washer, 3/8" SAE Hex Nut, 5/16"-18
5	GR1256	1	Arm
6	GR1258	1	Socket Shoulder Screw, 1/2"
7	GR1257	1	Stainless Steel Bushing
A	GA6782	-	Detent Lever Valve Complete
B	GR1260	-	Seal Kit (For GR1254 Valve), Includes: (2) BU Rings, (3) O-Rings

VVB039(HYD30)

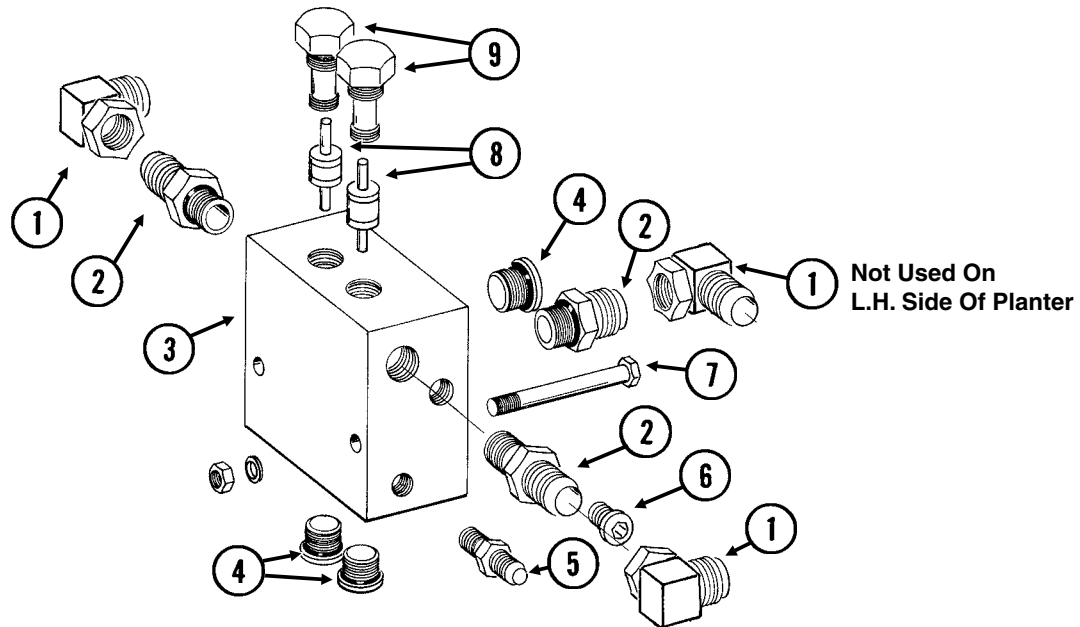

ITEM	PART NO.	QTY.	DESCRIPTION
1	G6500-08	2-3	Swivel Elbow, 90°, 3/4"-16 Male JIC To Female
	G6502-08	-	Swivel Elbow, 45°, 3/4"-16 Male JIC To Female
2	G6400-08	3	Connector W/O-Ring, 3/4"-16 Male JIC To O-Ring
	GR1037	-	O-Ring
3	GR1455	1	Block <b>(Non-Stock Item)</b>
4	GR1047	3	Hex Socket Plug W/O-Ring
	GR1037	-	O-Ring
5	G6400-04	1	Connector W/O-Ring, 7/16"-20 Male JIC To O-Ring
	GR1465	-	O-Ring
6	GR1034	1	Hex Socket Plug W/O-Ring
	GR1035	-	O-Ring
7	G10062	1	Hex Head Cap Screw, 3/8"-16 x 3"
	G10229	1	Lock Washer, 3/8"
	G10101	1	Hex Nut, 3/8"-16
8	GR1457	2	Pilot Piston <b>(Non-Stock Item)</b>
	GR1456	2	Cartridge <b>(Non-Stock Item)</b>
A	GA8409	-	Pilot Operated Check Valve (Items 3, 4, 6, 8 And 9)
B	GR1458	-	Seal Kit, Includes: (2) Cartridge Seal Kits, (5) O-Rings, (2) BU Rings

Stroke Limiter Valve

(FF23b)

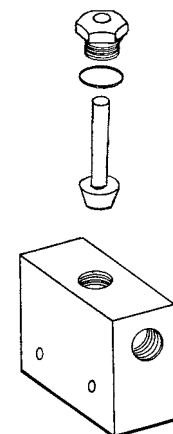

ITEM	PART NO.	QTY.	DESCRIPTION
A	GA12105	-	Stroke Limiter Valve Complete <i>(Part Number Stamped On Valve Block)</i>
B	G1K255	-	Repair Kit, Includes: (1) Adapter, (1) Poppet, (1) Seal Kit W/O-Rings And BU Ring

VVB019(TWL27c/TWL18/PLTR75c/A9481)

ITEM	PART NO.	QTY.	DESCRIPTION
1	GR0761	1	Special Hex Nut, 1/2"-20
2	G1K274	1	Coil Kit W/Contacts, Housings And Fork Terminals
	GD9529	2	Housing, Black
	GD9530	2	Contact
	G10996	2	Fork Terminal
3	GR0763	1	Cartridge
A	G1K275	-	Solenoid Valve Kit W/Solenoid Valve, Contacts, Housings And Fork Terminals
	GD9529	2	Housing, Black
	GD9530	2	Contact
	G10996	2	Fork Terminal
B	GR0764	-	Seal Kit, Includes: (2) O-Rings, (1) BU Ring

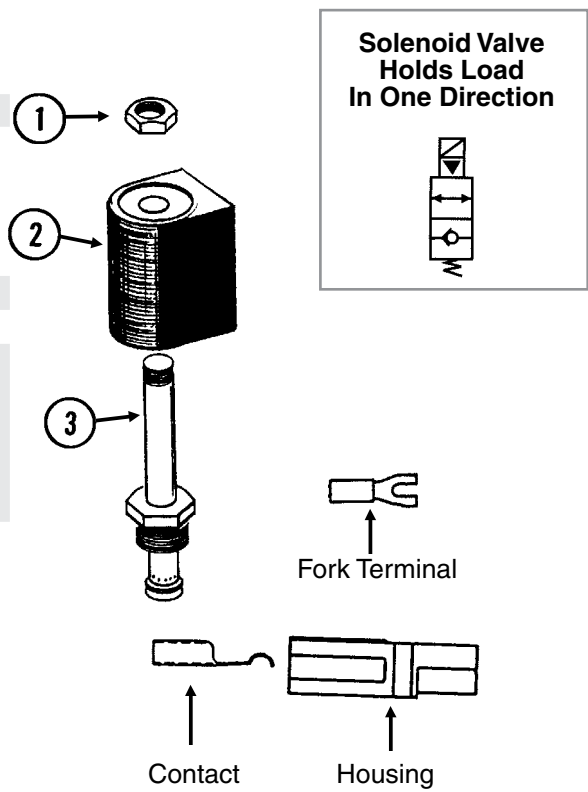

Solenoid Valve (G1K276)

VVB019(FF25/TWL18/PLTR75c)

ITEM	PART NO.	QTY.	DESCRIPTION
1	GR1322	1	Special Hex Nut, 1/2"-20
2	G1K274	1	Coil Kit W/Contacts, Housings And Fork Terminals
	GD9529	2	Housing, Black
	GD9530	2	Contact
	G10996	2	Fork Terminal
3	GR1321	1	Cartridge
A	G1K276	-	Solenoid Valve Kit W/Housings, Contacts, And Forked Terminals
	GD9529	2	Housing, Black
	GD9530	2	Contact
	G10996	2	Fork Terminal
B	GR2042	-	Seal Kit

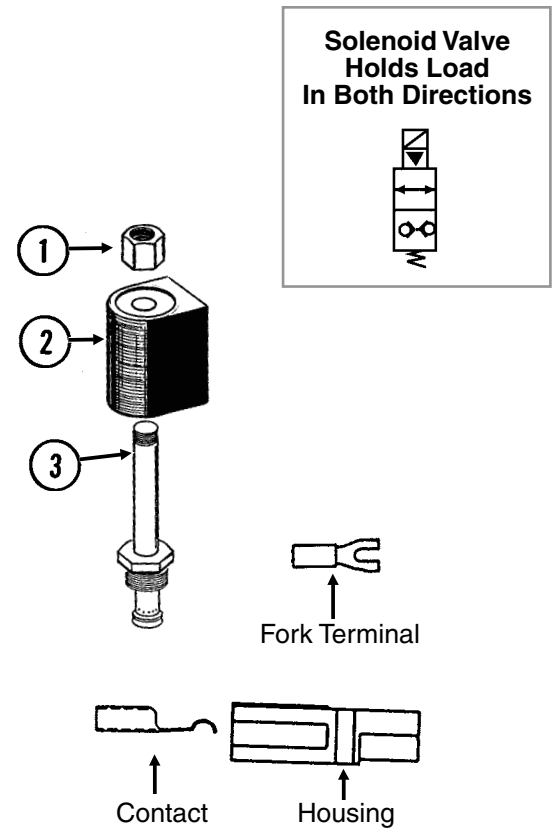

VVB020(TWL28)

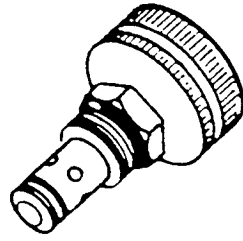

ITEM	PART NO.	QTY.	DESCRIPTION
A	GA3413	-	Flow Control Valve
B	GR0764	-	Seal Kit, Includes: (2) O-Rings, (1) BU Ring

**Pressure Relief Valves**

VVB020(FF46/FF46a/FF104)

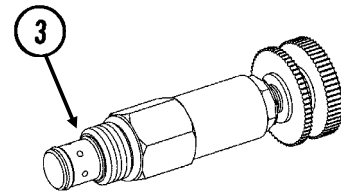
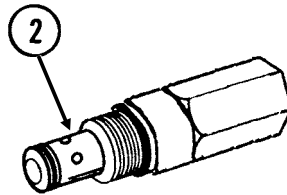
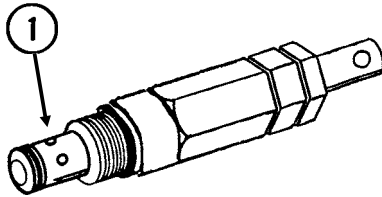

ITEM	PART NO.	QTY.	DESCRIPTION
1	GA8844 GR1515	- -	Pressure Relief Valve, 1500 PSI Seal Kit, Includes: (2) O-Rings, (1) BU Ring
2	GA10140 GR0764	- -	Pressure Relief Valve, 550 PSI Seal Kit, Includes: (2) O-Rings, (1) BU Ring
3	GA3407 GR0764	- -	Pressure Relief Valve, 1000 PSI Seal Kit, Includes: (2) O-Rings, (1) BU Ring

**Check Valve**

VVB020(TWL30)

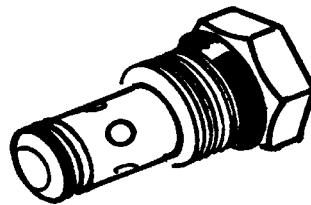

ITEM	PART NO.	QTY.	DESCRIPTION
A	GA4293	-	Check Valve
B	GR0764	-	Seal Kit, Includes: (2) O-Rings, (1) BU Ring

(IP1075)

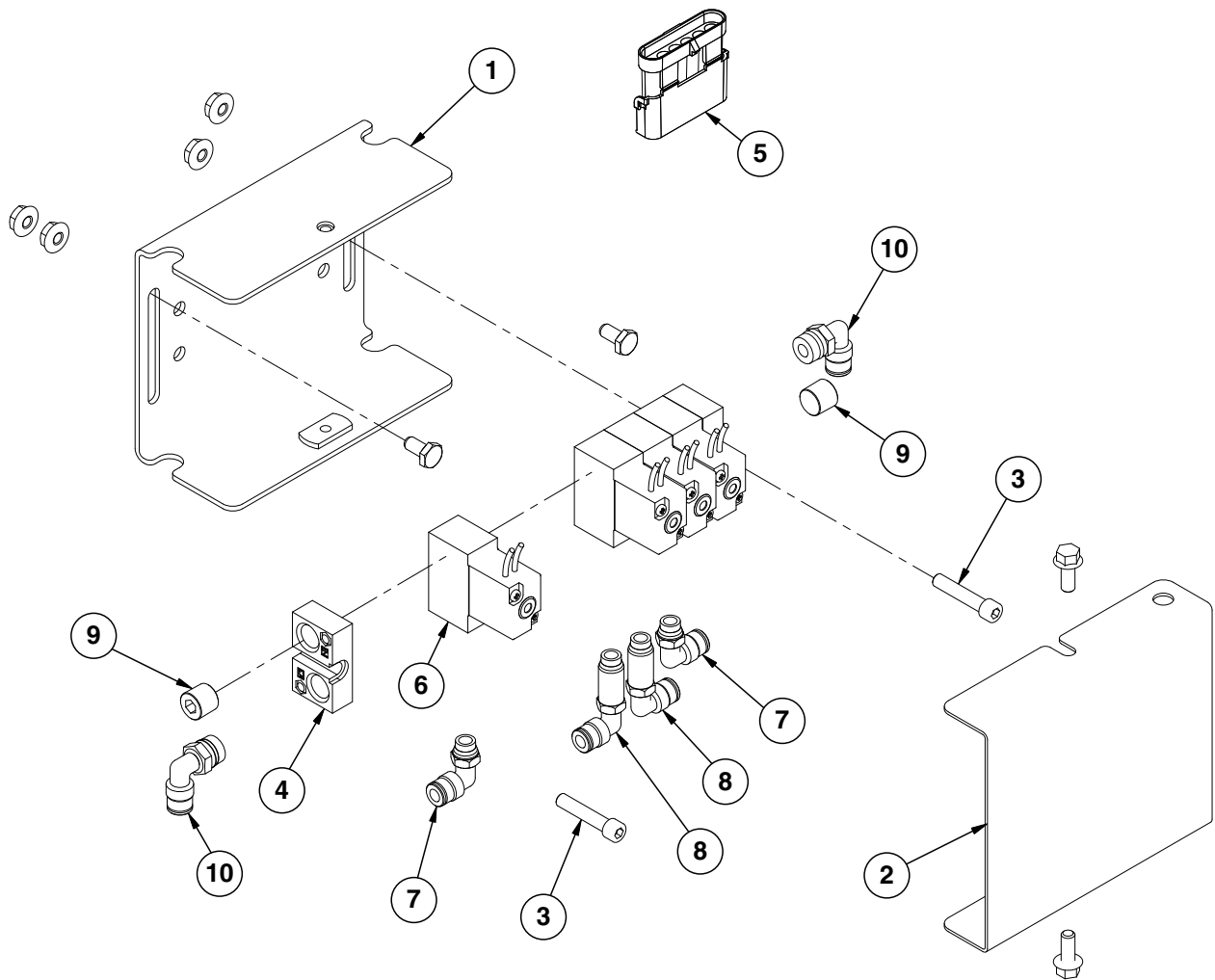

ITEM	PART NO.	QTY.	DESCRIPTION
1	GA13574	1	Clutch Valve Bracket
	G10621	4	Serrated Flange Nut, 1/4"-20
	G10022	2	Hex Head Cap Screw, 1/4"-20 x 1/2"
2	GD19190	1	Clutch Valve Cover
	G10960	2	Flanged Whiz Lock Screw, 1/4"-20 x 5/8", No Serration
3	G11276	2	Hex Socket Head Cap Screw, 1/4"-20 X 1 1/4"
4	GR1914	1	Solenoid Valve End Plate Kit
5	GD15687	1	6 Pin Connector
6	GR1913	4	Solenoid Clutch Valve
7	GD19080	2	Elbow, 1/4" x 1/8" NPT Swivel
8	GD19298	2	Elbow, 1/4" Male Swivel Extended
9	GD17156	2	Plug, 1/4" NPT
10	GD17148	2	Male Connector, 1/4"
A	GA13529	1	Clutch Valve Assembly (Items 4-8)

(IP1094)

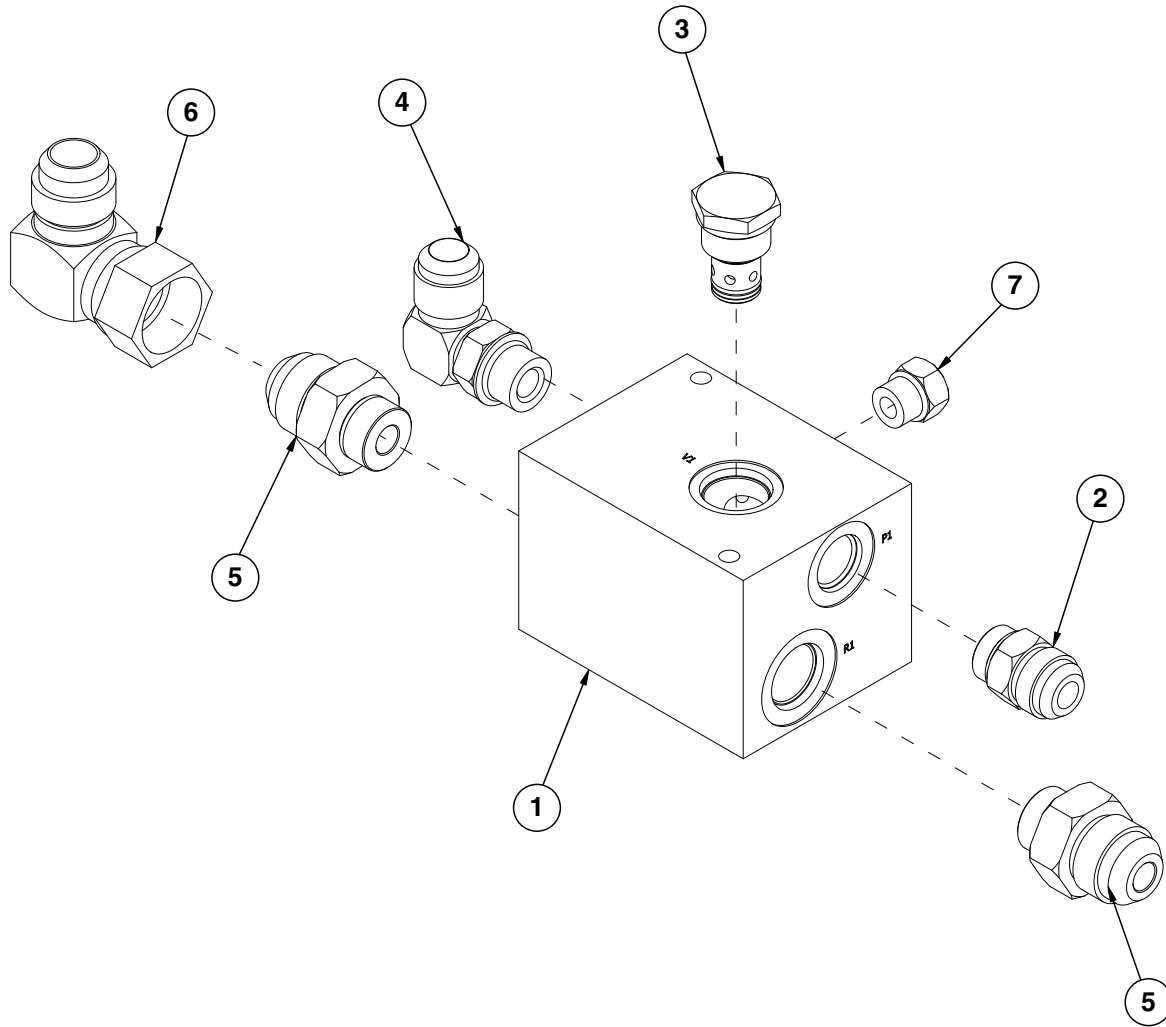

ITEM	PART NO.	QTY.	DESCRIPTION
1	GD19123	1	Block
2	G6400-10-08	1	Connector W/O-Ring, 7/8"-14 Male JIC To 3/4"-16 O-Ring
	GR1037	-	O-Ring
3	GA4293	1	Check Valve
4	G6801-10-08	1	Elbow W/O-Ring, 90°, 7/8"-14 Male JIC To 3/4"-16 O-Ring
	GR1037	-	O-Ring
5	G6400-12-10	2	Connector W/O-Ring, 1 1/16"-12 Male JIC To 7/8"-14 O-Ring
6	G6500-12	1	Swivel Elbow, 90°, 1 1/16"-12 Male JIC To Female
7	G6408-06	1	Plug W/O-Ring, 9/16"-18 O-Ring
	GR1045	-	O-Ring

**This page left blank intentionally.**

(FF97a)

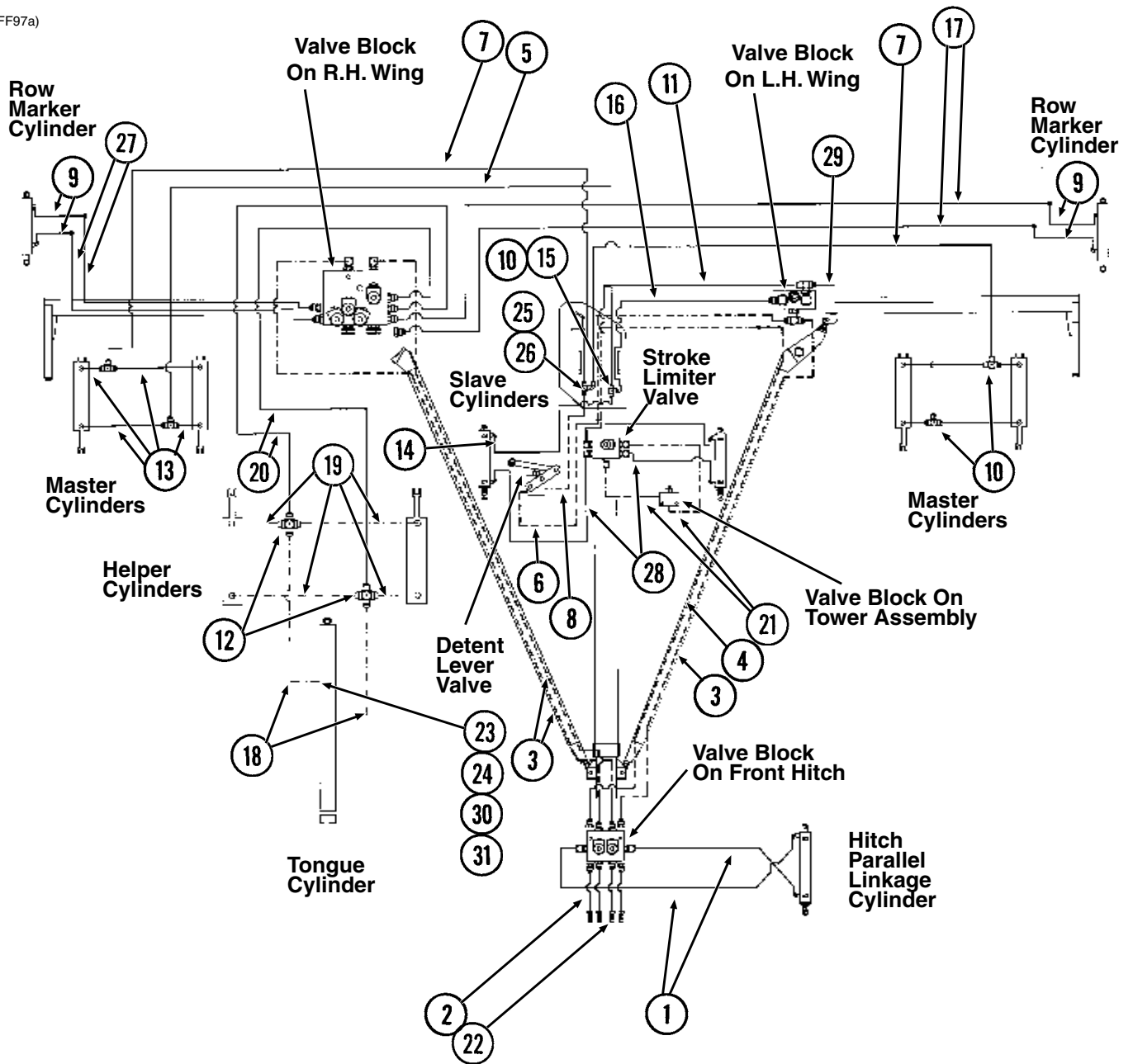

ITEM	PART NO.	QTY.	DESCRIPTION
1	*A1044	2	Hose Assembly, 3/8" x 34"
2	*A1412	4	Hose Assembly, 1/2" x 130"
3	*A1499	3	Hose Assembly, 1/2" x 280"
4	*A1498	1	Hose Assembly, 1/2" x 452"
5	*A1089	1	Hose Assembly, 3/8" x 240"
6	*A1487	1	Hose Assembly, 1/2" x 150"
7	*A3196	2	Hose Assembly, 3/8" x 240"
8	*A1404	1	Hose Assembly, 1/2" x 41"
9	*A1072	4	Hose Assembly, 3/8" x 48"
10	G2603-08	5	Tee, 3/4"-16 Male JIC
11	*A1049	1	Hose Assembly, 3/8" x 160"
12	G2650-06	2	Cross, 9/16"-18 Male JIC
13	*A3119	8	Hose Assembly, 3/8" x 36"
14	*A1020	1	Hose Assembly, 3/8" x 48"
15	G6500-08	1	Swivel Elbow, 90°, 3/4"-16 Male JIC To Female
16	*A1010	1	Hose Assembly, 3/8" x 120"
17	*A3271	2	Hose Assembly, 3/8" x 402"
18	*A1146	2	Hose Assembly, 1/4" x 12"
19	*A1189	4	Hose Assembly, 1/4" x 36"
20	*A12026	2	Hose Assembly, 3/8" x 148"
21	*A1424	2	Hose Assembly, 1/2" x 30"
22	GD4086	4	ISO Coupler
23	G6400-06-08 GR1037	1 -	Connector W/O-Ring, 9/16"-18 Male JIC To 3/4"-16 O-Ring O-Ring
24	G6502-06	2	Swivel Elbow, 45°, 9/16"-18 Male JIC To Female
25	G2603-10	1	Tee, 7/8"-14 Male JIC
26	G6500-10	1	Swivel Elbow, 90°, 7/8"-14 Male JIC To Female
27	*A1025	2	Hose Assembly, 3/8" x 148"
28	*A3119	2	Hose Assembly, 3/8" x 36"
29	*A1010	1	Hose Assembly, 3/8" x 120"
30	*G6500-06	1	Swivel Elbow, 90°, 9/16"-18 Male JIC To Female
31	G2406-08-06	1	Reducer, 3/4"-16 Female JIC To 9/16"-18 Male JIC

\*Hydraulic hose is not stocked by Kinze Repair Parts, but can be made available on a special order basis. Call for quote.

(IP1142-1a)

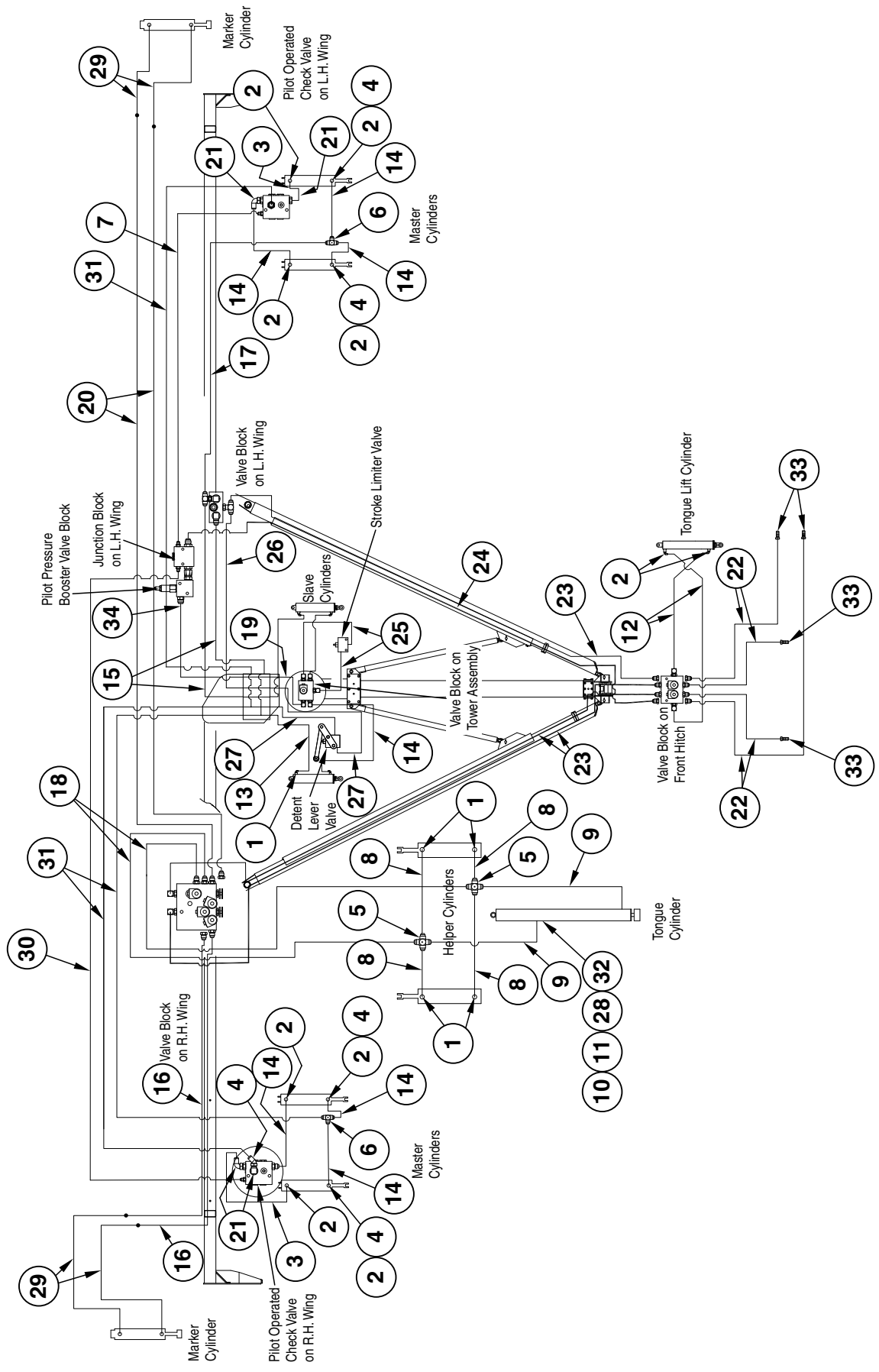

ITEM	PART NO.	QTY.	DESCRIPTION
1	G6801-06-08 GR1037	8	Connector W/O-Ring, 9/16"-18 Male JIC To 3/4"-16 O-Ring O-Ring
2	G6801-08 GR1037	10	Elbow W/O-Ring, 90°, 3/4"-16 Male JIC To O-Ring O-Ring
3	*A1073	2	Hose Assembly, 3/8" x 18"
4	G6502-08	5	Swivel Elbow, 45°, 3/4"-16 Male JIC To Female
5	G2650-06	2	Cross, 9/16"-18 Male JIC
6	G2603-08	2	Tee, 3/4"-16 Male JIC
7	*A8500	1	Hose Assembly, 3/16" x 260"
8	*A1189	4	Hose Assembly, 1/4" x 36"
9	*A1146	2	Hose Assembly, 1/4" x 12"
10	G6400-06-08 GR1037	1	Connector W/O-Ring, 9/16"-18 Male JIC To 3/4"-16 O-Ring O-Ring
11	G6502-06	2	Swivel Elbow, 45°, 9/16"-18 Male JIC To Female
12	*A1044	2	Hose Assembly, 3/8" x 34"
13	*A3140	2	Hose Assembly, 3/8" x 94"
14	*A3119	8	Hose Assembly, 3/8" x 36"
15	*A3111	2	Hose Assembly, 3/8" x 200"
16	*A1031	2	Hose Assembly, 3/8" x 234"
17	*A3161	1	Hose Assembly, 3/8" x 210"
18	*A3299	2	Hose Assembly, 3/8" x 164"
19	*A8201	1	Hose Assembly, 1/2" x 90"
20	*A12000	2	Hose Assembly, 3/8" x 548"
21	G6500-08	3	Swivel Elbow, 90°, 3/4"-16 Male JIC To 9/16"-18 Female
22	*A1412	4	Hose Assembly, 1/2" x 130"
23	*A1485	3	Hose Assembly, 1/2" x 330"
24	*A8208	1	Hose Assembly, 1/2" x 374"
25	*A8273	2	Hose Assembly, 1/2" x 21"
26	*A12749	1	Hose Assembly, 1/2" x 198"
27	*A1465	2	Hose Assembly, 1/2" x 84"
28	G2406-08-06	1	Reducer, 3/4"-16 Female JIC To 9/16"-18 Male JIC
29	*A1072	4	Hose Assembly, 3/8" x 48"
30	*A8501	1	Hose Assembly, 3/16" x 426"
31	*A12082	3	Hose Assembly, 3/8" x 418"
32	G6500-06	1	Swivel Elbow, 90°, 9/16"-18 Male JIC To Female
33	GD4086	4	ISO Coupler
34	*A8283	1	Hose Assembly, 1/2" x 158"

\*Hydraulic hose is not stocked by Kinze Repair Parts, but can be made available on a special order basis. Call for quote.

(IP1179)

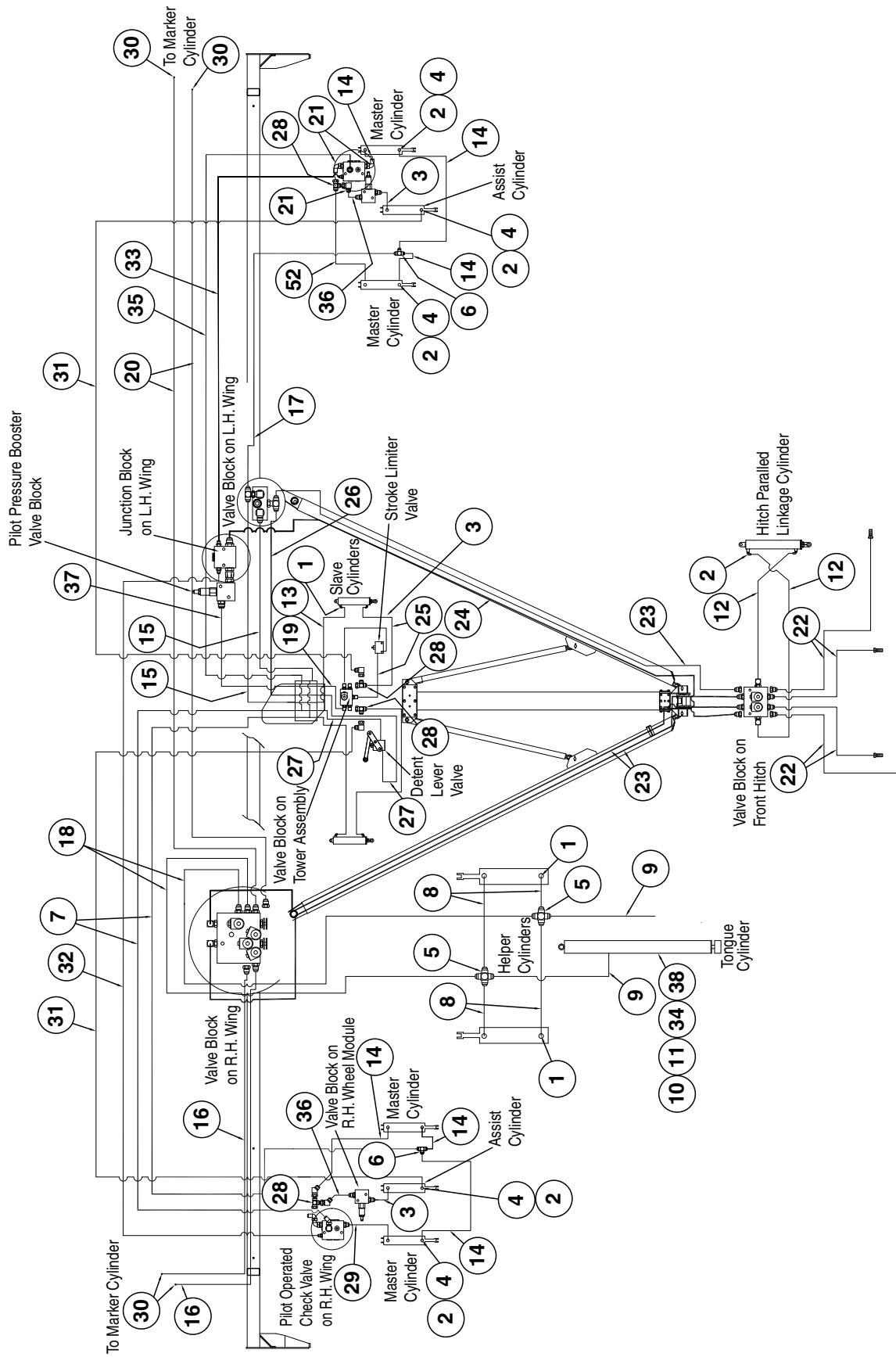

ITEM	PART NO.	QTY.	DESCRIPTION
1	G6801-06-08 GR1037	8	Connector W/O-Ring, 3/16"-18 Male JIC To 3/4"-16 O-Ring O-Ring
2	G6801-08 GR1037	14	Elbow W/O-Ring, 90°, 3/4"-16 Male JIC To O-Ring O-Ring
3	*A1098	4	Hose Assembly, 3/8" x 26"
4	G6502-08	15	Swivel Elbow, 45°, 3/4"-16 Male JIC To Female
5	G2650-06	2	Cross, 3/16"-18 Male JIC
6	G2603-08	2	Tee, 3/4"-16 Male JIC
7	*A12082	2	Hose Assembly, 3/8" x 418"
8	*A1189	4	Hose Assembly, 1/4" x 36"
9	*A1146	2	Hose Assembly, 1/4" x 12"
10	G6400-06-08 GR1037	1	Connector W/O-Ring, 3/16"-18 Male JIC To 3/4"-16 O-Ring O-Ring
11	G6502-06	2	Swivel Elbow, 45°, 3/16"-18 Male JIC To Female
12	*A1044	2	Hose Assembly, 3/8" x 34"
13	*A3140	2	Hose Assembly, 3/8" x 94"
14	*A3119	6	Hose Assembly, 3/8" x 36"
15	*A3111	2	Hose Assembly, 3/8" x 200"
16	*A1031	2	Hose Assembly, 3/8" x 234"
17	*A1057	1	Hose Assembly, 3/8" x 216"
18	*A3299	2	Hose Assembly, 3/8" x 164"
19	*A8201	1	Hose Assembly, 1/2" x 90"
20	*A12000	2	Hose Assembly, 3/8" x 548"
21	G6500-08	8	Swivel Elbow, 90°, 3/4"-16 Male JIC To Female
22	*A1412	4	Hose Assembly, 1/2" x 130"
23	*A1485	3	Hose Assembly, 1/2" x 330"
24	*A8208	1	Hose Assembly, 1/2" x 374"
25	*A8273	2	Hose Assembly, 1/2" x 21"
26	*A12749	1	Hose Assembly, 1/2" x 198"
27	*A1465	2	Hose Assembly, 1/2" x 84"
28	G6602-08	4	Swivel Tee, 3/4"-16 JIC
29	*A1019	2	Hose Assembly, 3/8" x 44"
30	G2408-08	4	Plug, 3/4"-16 JIC
31	*A3178	2	Hose Assembly, 3/8" x 536"
32	*A8503	1	Hose Assembly, 3/16" x 436"
33	*A8502	1	Hose Assembly, 3/16" x 270"
34	G2406-08-06	1	Reducer, 3/4"-16 Female JIC To 3/16"-18 Male JIC
35	*A12083	1	Hose Assembly, 3/8" x 436"
36	*A3122	2	Hose Assembly, 3/8" x 10 1/2"
37	*A8283	1	Hose Assembly, 1/2" x 158"
38	G6500-06	1	Swivel Elbow, 90°, 3/16"-18 Male JIC To Female

\*Hydraulic hose is not stocked by Kinze Repair Parts, but can be made available on a special order basis. Call for quote.

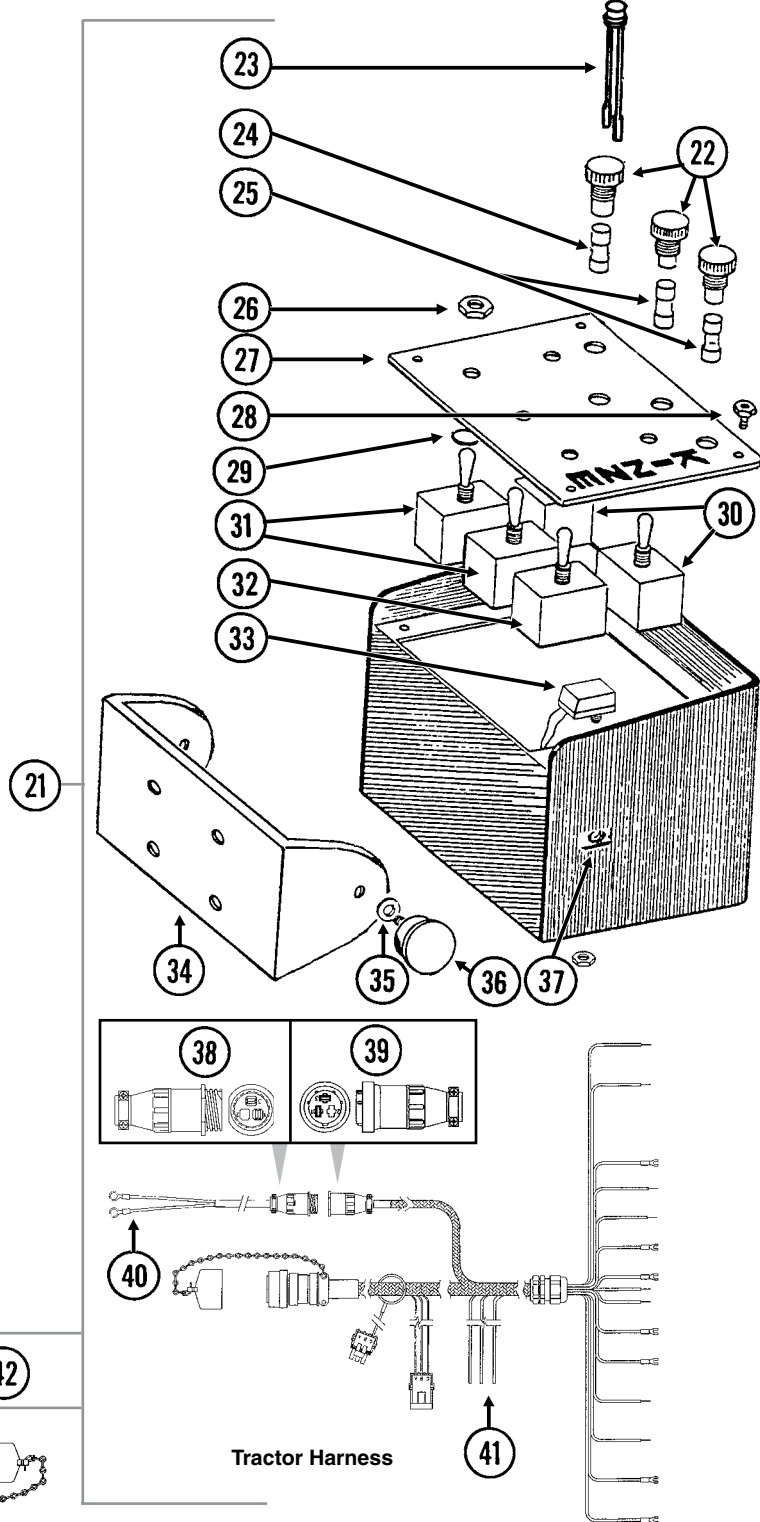
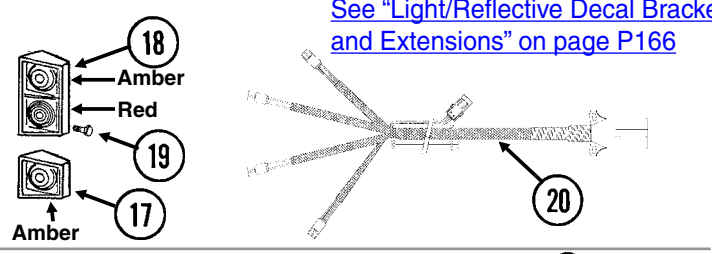
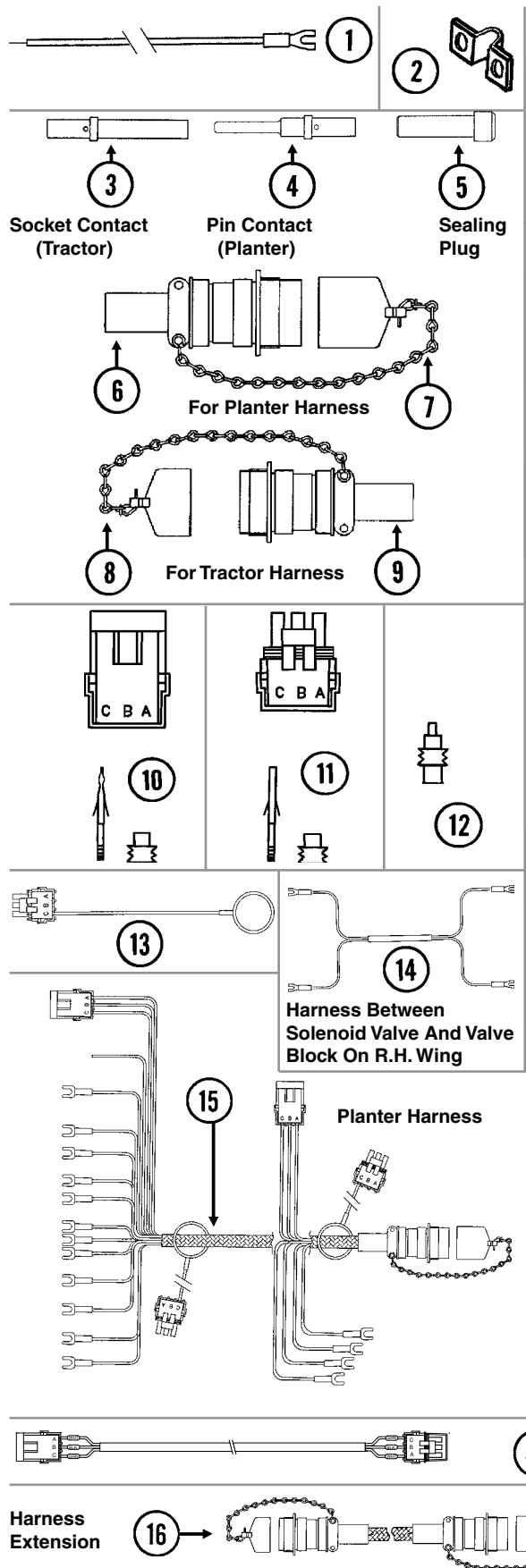

ITEM	PART NO.	QTY.	DESCRIPTION
1	GA9481	-	Jumper Wire W/Fork Terminal, 13"
	G10996	-	Fork Terminal
2	GD13310	-	Jumper, 7/16"
3	GD8740	-	Socket Contact, No. 14
4	GD8741	-	Pin Contact, No. 14
5	GD8739	-	Sealing Plug, No. 12
6	GA6109	1	Connector W/Cable Clamp, 23 Pin Capacity
7	GA7862	-	Dust Cap W/Chain
8	GA7863	-	Dust Cap W/Chain
9	GA6108	1	Connector W/Cable Clamp, 23 Socket Capacity
10	G1K248	-	3-Pin Female Connector Kit (Black), Includes: (3) 3-Pin Female Housings, (9) Pin Contacts, (9) Seals
11	G1K252	-	3-Pin Male Connector Kit (Black), Includes: (3) 3-Pin Male Housings, (9) Socket Contacts, (9) Seals
12	GD11089	-	Sealing Plug
13	GA8047	-	Dust Plug (Black)
14	GA9513	1	Wiring Harness, 312", From Valve Block On R.H. Wing To Tower Assembly
15	GA9496	1	Wiring Harness W/Dust Cap, 468"
16	GA11736	-	Harness Extension W/Dust Caps, 180"
17	GA6701	1	Single Amber Light Assembly
	GR1204	-	Amber Lens
	GR1206	-	Rubber Grommet (2)
	GR1207	-	Lamp Unit
	GR1208	-	Bulb
18	GA6699	1	Double Light Assembly
	GA6700	1	Double Light Assembly (Shown)
	GR1203	-	Red Lens
	GR1204	-	Amber Lens
	GR1205	-	Cover
	GR1206	-	Rubber Grommet (4)
	GR1207	-	Lamp Unit
	GR1208	-	Bulb
19	G10064	8	Hex Head Cap Screw, 1/4"-20 x 1"
	G10857	8	Hex Head Cap Screw, 1/4"-20 x 1 1/4"
	G10110	16	Lock Nut, 1/4"-20, Grade B
20	GA9502	1	Wiring Harness W/7 Terminal Female Connector, 659" (4 Light Connections)
	GA5385	-	7 Terminal Female Connector
21	G7633X	-	Backlit Control Console Assembly W/Mounting Brackets, Short Harness W/Dust Cap And Power Cable (Shown)
	G7639X	-	Backlit Control Console Assembly W/Mounting Brackets, Short Harness W/Dust Cap And Power Cable, Planters Equipped With Two-Speed Point Row Clutches
22	GA2612	3-5	Fuse Holder W/Spade, 1 <sup>33</sup> / <sub>50</sub> "
23	GA7077	1-4	Indicator Light
24	GD2829	1-2	Fuse, 15 Amp, Type AGC
25	GD10243	2-6	Fuse, MDL 10 Amp Delay Action
26	GR1363	5	Hex Face Nut, 1 <sup>5</sup> / <sub>32</sub> "-32
	GR1364	5	Internal Tooth Lock Washer, 1 <sup>5</sup> / <sub>32</sub> "
27	GA8734	1	Cover Plate (Shown)
	GA8735	-	Cover Plate, Planters Equipped With Two-Speed Point Row Clutches
28	GR1292	4	Pan Head Screw, No. 8-32 x 1/2"
29	GD3860	-	O-Ring (If Applicable)
30	GA2528	2	Switch, 3 Position Toggle, On-Off-On
31	GA6978	2	Switch, 3 Position Toggle, Momentary On-Off-Momentary On

ITEM	PART NO.	QTY.	DESCRIPTION
32	GA6977	1-2	Switch, 2 Position Toggle, On-Off
33	GA8731	1	Switch, Push Button W/Transformer
34	GD9896	1	Mounting Bracket
35	G11385	4	Flat Washer, ¼" SAE
36	GA6975	2	Knob
37	GR1290	2	Cage Nut, ¼"-20
38	G1K267	-	Power Lead Adapter Connector Kit, Includes: (1) 3-Pin Connector, (1) Cable Clamp, (3) Male Terminal Pins
39	G1K268	-	Console Cable Connector Kit, Includes: (1) 3-Pin Connector, (1) Cable Clamp, (1) Lock Ring, (3) Female Terminal Pins
40	GA7856	1	Power Lead Adapter
41	GA8729	1	Wiring Harness W/Dust Cap And Power Cable
42	GA7855	1	Extension, 30'

**NOTE:** See ["Point Row Clutch" on page P113](#) or See ["Two-Speed Point Row Clutch" on page P115](#) for R.H. and L.H. Wiring Harnesses for the point row clutches. See display unit for those components.

(RU130b/RU129/RU133/RU132/RU130a/RU131/RU129a/RU132a)

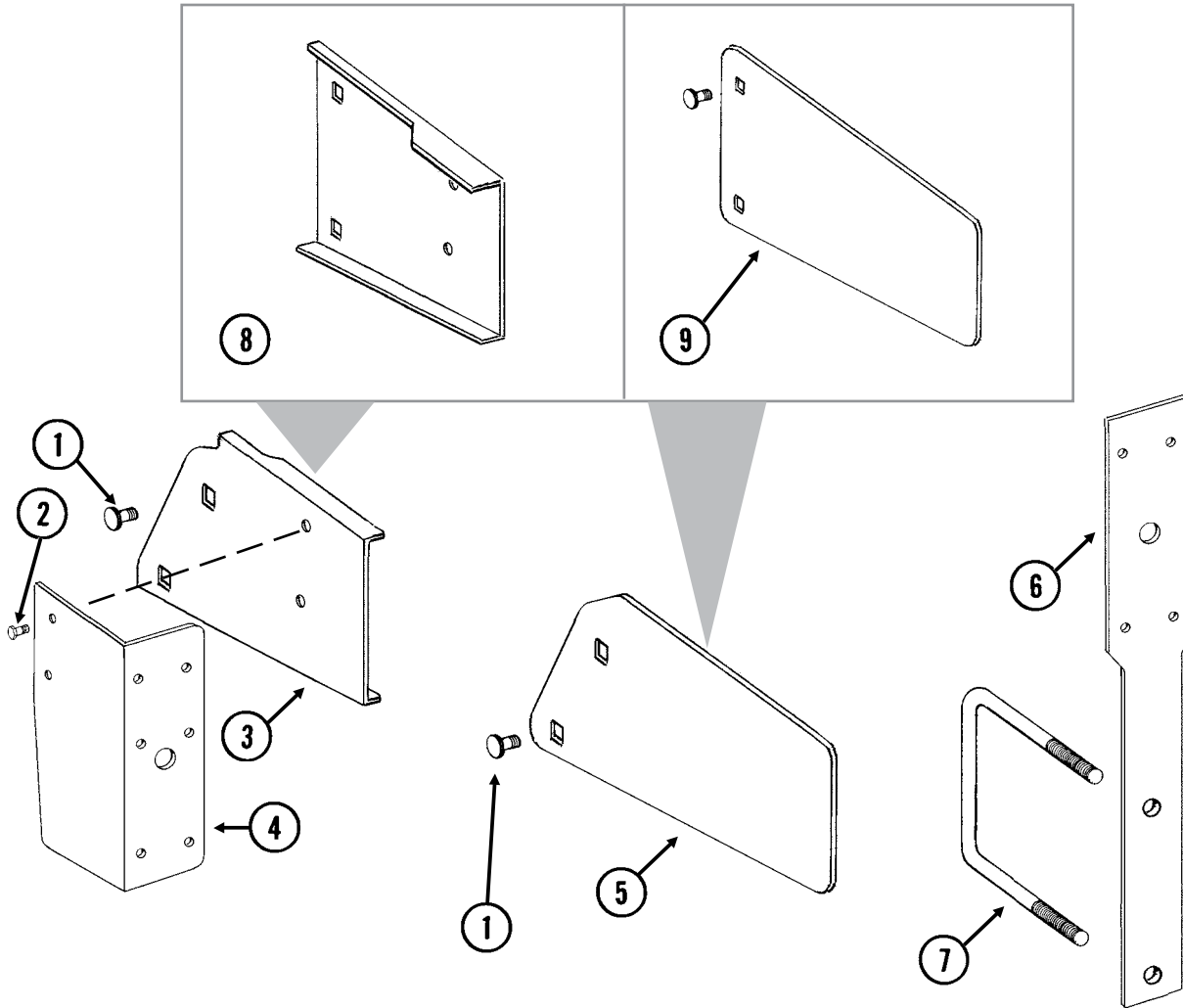

ITEM	PART NO.	QTY.	DESCRIPTION
1	G10312	-	Carriage Bolt, 5/16"-18 x 3/4"
	G10620	-	Serrated Flange Nut, 5/16"-18
2	G10064	-	Hex Head Cap Screw, 1/4"-20 x 1"
	G10110	-	Hex Nut, 1/4"-20
3	GD15968	1	Light Mount Extension
4	GD12725	1	Bracket (L.H. Wing)
	GD12724	1	Bracket (R.H. Wing) (Shown)
5	GD15967	1	Reflective Decal Bracket
6	GD13358	2	Light Bracket
7	GD17039	2	U-Bolt, 7" x 7" x 5/8"-11
	G10230	4	Lock Washer, 5/8"
	G10104	4	Hex Nut, 5/8"-11
8	GD12723	1	Light Mount Extension
9	GD12710	1	Reflective Decal Bracket

(MTR43w)

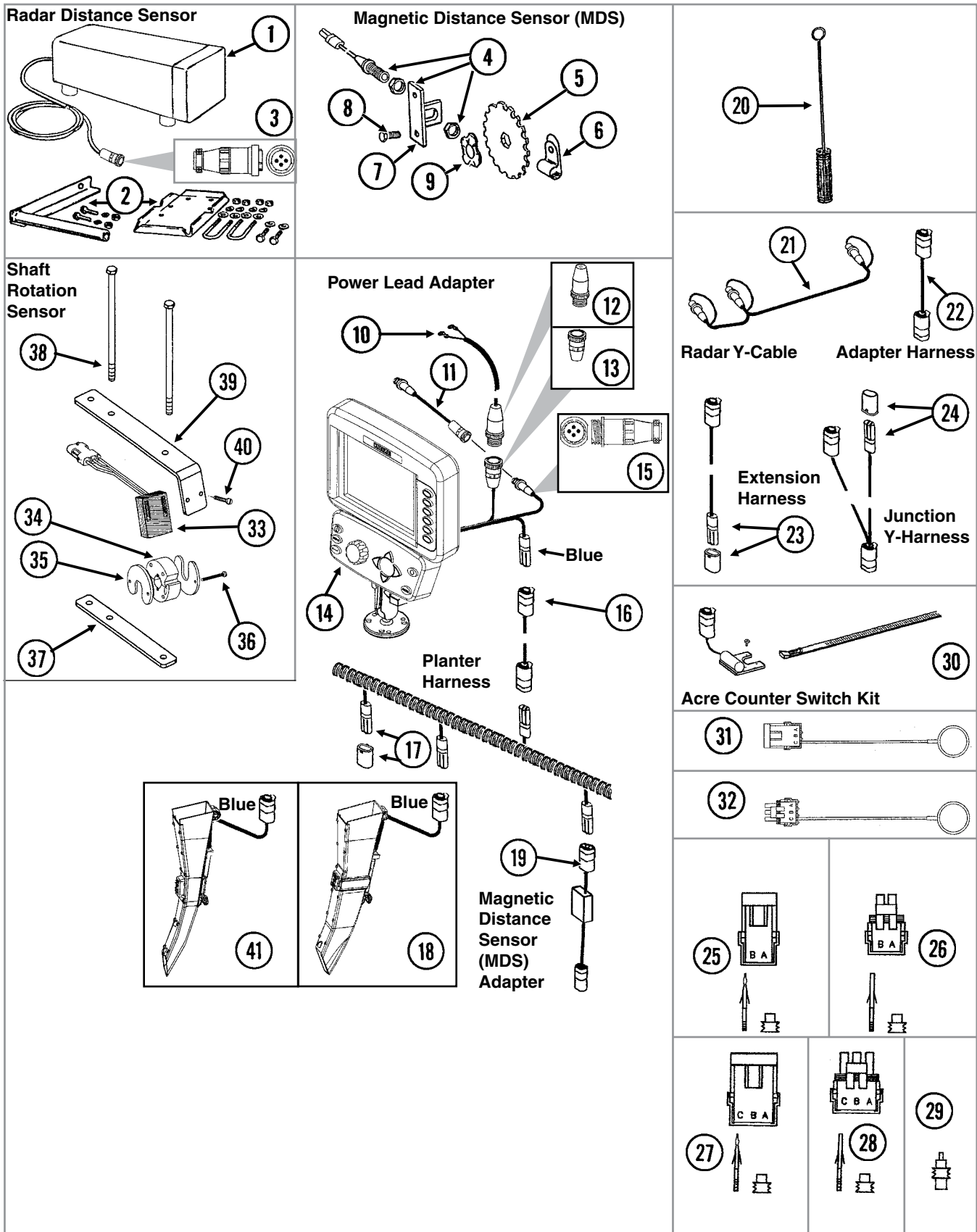

ITEM	PART NO.	QTY.	DESCRIPTION
1	GA7858	-	Radar Distance Sensor W/20' Cable
2	GA8026	-	Radar Sensor Pipe/Mounting Bracket Package
3	G1K323	-	4-Pin Connector Kit W/Female Housing, Includes: (4) Pins, (1) Cable Clamp
4	GA5600	1	Magnetic Distance Sensor
5	GD8751	-	Magnetic Distance Sensor Pulse Wheel
6	GD6291	-	Insulated Clamp, 3/8"
7	GD8770	1	Bracket
8	G10001	2	Hex Head Cap Screw, 3/8"-16 x 1"
	G10229	2	Lock Washer, 3/8"
	G10101	2	Hex Nut, 3/8"-16
9	GD8771	1	Spring Wave Washer
10	GA7856	1	Power Lead Adapter
11	GA9144	-	Monitor/Radar Adapter Cable, 10"
12	G1K267	-	Power Lead Adapter Connector Kit, Includes: (1) Cable Clamp, (1) 3-Pin Connector, (3) Male Terminal Pins
13	G1K268	-	Console Cable Connector Kit, Includes: (1) Cable Clamp, (1) 3-Pin Connector, (1) Lock Ring, (3) Female Terminal Pins
14	GA11039	1	KPM III Backlit Console W/Brush (Item 23), Dust Plug (Item 34), Mounting Bracket Assembly, Console Mounting Bracket Hardware And Power Harness
	GA12403	-	Mounting Bracket Assembly, Includes: (2) Mounting Brackets, (2) Connector Halves, (1) Compression Spring, (1) Tension Knob, (1) 1/4"-20 x 1 3/4" Hex Head Cap Screw, (1) 1/4" Plastic Washer, (1) 1/4" Steel Washer
	GR1762	-	Console Mounting Bracket Hardware Package, Includes: (3) No. 10-32 x 5/8" Hex Socket Pan Head Screws, (3) No. 10 Lock Washers
	GR1764	-	Power Harness
15	G1K322	-	4-Pin Connector Kit W/Male Housing, (4) Female Socket Contacts and (1) Cable Clamp
16	---	-	Included In Tractor/Planter Wiring Harness, <a href="#">See "Electrical Components" on page P163</a>
17	GA7852	-	Planter Harness W/Dust Caps, 16 Row (20 Connectors)
	GA8050	-	Planter Harness W/Dust Caps, 18 Row (22 Connectors)
	GD11993	-	Dust Cap
18	GA12166	-	Seed Tube W/Computerized Sensor (EdgeVac)
	GR1785	-	Sensor Only, EdgeVac
	GA12636	-	Seed Tube (With Holes For Sensor Installation)(EdgeVac)
19	GA7859	1	Magnetic Distance Sensor Adapter (Analog To Digital)
20	GR0594	-	Brush
21	GR0586	1	Radar Y-Cable (Used To Connect Radar Distance Sensor For Multiple Functions)
22	GA7857	-	Adapter Harness, 1'
23	GA7854	-	Extension Harness W/Dust Cap, 15'
	GA7855	-	Extension Harness W/Dust Cap, 30'
	GD11993	-	Dust Cap
24	GA7853	-	Junction Y-Harness W/Dust Cap
	GD11993	-	Dust Cap
25	G1K321	-	2-Pin Female Connector Kit (Black), Includes: (3) 2-Pin Female Housings, (6) Pin Contacts, (6) Seals
26	G1K320	-	2-Pin Male Connector Kit (Black), Includes: (3) 2-Pin Male Housings, (6) Socket Contacts, (6) Seals

ITEM	PART NO.	QTY.	DESCRIPTION
27	G1K248	-	3-Pin Female Connector Kit (Black), Includes: (3) 3-Pin Female Housings, (9) Pin Contacts, (9) Seals
	G1K362	-	3-Pin Female Connector Kit (Blue), Includes: (3) 3-Pin Female Housings, (9) Pin Contacts, (9) Seals
28	G1K252	-	3-Pin Male Connector Kit (Black), Includes: (3) 3-Pin Male Housings, (9) Socket Contacts, (9) Seals
	G1K363	-	3-Pin Male Connector Kit (Blue), Includes: (3) 3-Pin Male Housings, (9) Socket Contacts, (9) Seals
29	GD11089	-	Sealing Plug
30	G1K249	-	Acre Counter Switch Kit
31	GA8046	-	Dust Plug (Black)
	GA9978	-	Dust Plug (Blue)
32	GA8047	-	Dust Plug (Black)
	GA9979	-	Dust Plug (Blue)
33	GR1415	1	Rotation Sensor
34	GR1414	1	Actuator
35	GD11474	4	Cover
36	G10927	4	Pan Head Machine Screw, No. 8-32 x 1¼", Stainless Steel
	G10931	4	Lock Washer, No. 8, Internal/External, Stainless Steel
	G10928	4	Hex Nut, No. 8-32, Stainless Steel
37	GD18168	2	Mount
38	G10686	4	Hex Head Cap Screw, ⅜"-16 x 8"
	G10229	4	Lock Washer, ⅜"
	G10101	4	Hex Nut, ⅜"-16
39	GD18118	2	Shaft Sensor Mount
40	G11288	4	Pan Head Screw, No. 10-32 x 1½"
	G10243	4	Washer, No. 10 SAE
	G10758	4	Hex Nut, No. 10-32
41	GA14214	-	Seed Tube W/Computerized Sensor (Mechanical)
	GR1949	-	Sensor Only (Mechanical)
	GA10940	-	Seed Tube (W/Holes for Sensor Installation)(Mechanical)
A	GA6147	-	Magnetic Distance Sensor And Mounting Package (Items 4-9)
B	GA13521	-	Shaft Sensor Mounting Package (Items 35-40)
C	GA8135	-	Shaft Rotation Kit, Includes: (2) Actuators (2) Rotation Sensors

**This page left blank intentionally.**

(MTR60/MTR63/PMM01/MTR65/MTR61/MTR64/MTR62/PMM02)

**Shaft Rotation Sensor**

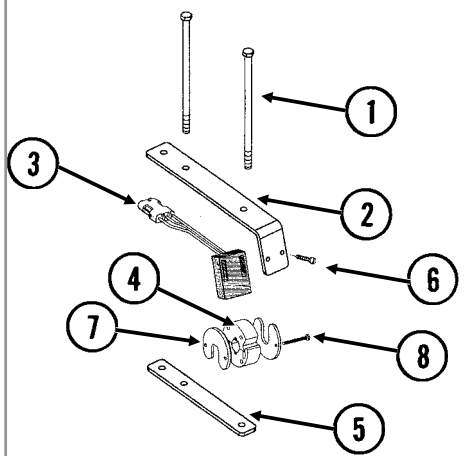

**Magnetic Distance Sensor (MDS)**

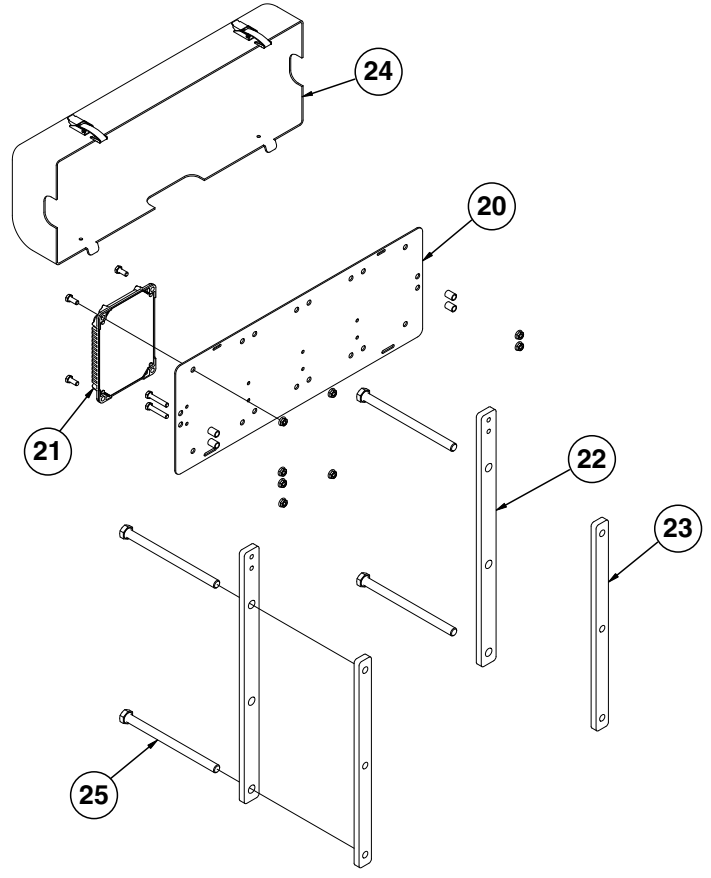
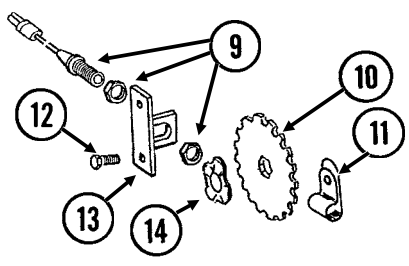

**Planter Harness**

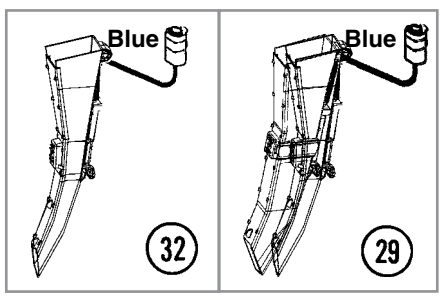
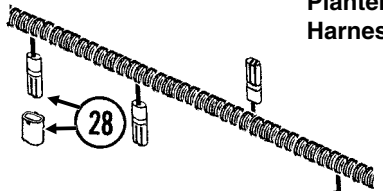

**30**  
Magnetic Distance Sensor (MDS) Adapter

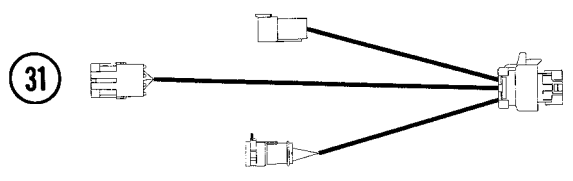
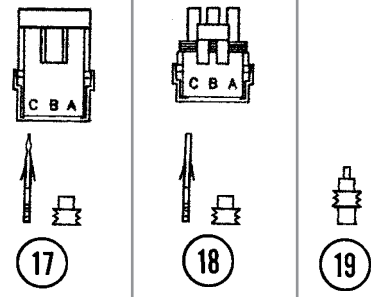
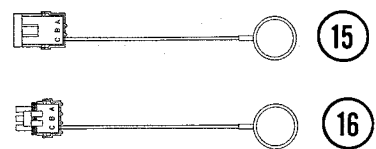

ITEM	PART NO.	QTY.	DESCRIPTION
1	G10686	4	Hex Head Cap Screw, 3/8"-16 x 8"
	G10229	4	Lock Washer, 3/8"
	G10101	4	Hex Nut, 3/8"-16
2	GD18118	2	Shaft Sensor Mount
3	GR1415	1	Rotation Sensor
4	GR1414	1	Actuator
5	GD18168	2	Mount
6	G10757	2	Pan Head Screw, No. 10-32 x 1 1/4"
	G10243	2	Washer, No. 10 SAE
	G10758	2	Hex Nut, No. 10-32
7	GD11474	4	Cover
8	G10927	4	Pan Head Machine Screw, No. 8-32 x 1 1/4", Stainless Steel
	G10931	4	Lock Washer, No. 8, Internal/External, Stainless Steel
	G10928	4	Hex Nut, No. 8-32, Stainless Steel
9	GA5600	1	Magnetic Distance Sensor
10	GD8751	-	Magnetic Distance Sensor Pulse Wheel
11	GD6291	-	Insulated Clamp, 3/8"
12	G10001	2	Hex Head Cap Screw, 3/8"-16 x 1"
	G10229	2	Lock Washer, 3/8"
	G10101	2	Hex Nut, 3/8"-16
13	GD8770	1	Bracket
14	GD8771	1	Spring Wave Washer
15	GA8046	-	Dust Plug (Black)
	GA9978	-	Dust Plug (Blue)
16	GA8047	-	Dust Plug (Black)
	GA9979	-	Dust Plug (Blue)
17	G1K248	-	3-Pin Female Connector Kit (Black), Includes: (3) 3-Pin Female Housings, (9) Pin Contacts, (9) Seals
	G1K362	-	3-Pin Female Connector Kit (Blue), Includes: (3) 3-Pin Female Housings, (9) Pin Contacts, (9) Seals
18	G1K252	-	3-Pin Male Connector Kit (Black), Includes: (3) 3-Pin Male Housings, (9) Socket Contacts, (9) Seals
	G1K363	-	3-Pin Male Connector Kit (Blue), Includes: (3) 3-Pin Male Housings, (9) Socket Contacts, (9) Seals
19	GD11089	-	Sealing Plug
20	GD18013	1	Bracket
	G10031	4	Hex Head Cap Screw, 5/16"-18 x 1 3/4"
	GD11963-01	4	Spacer, 1 1/16"
	G10620	8	Serrated Flange Nut, 5/16"-18
21	GA12538	1	Planter Monitor Module
	G10991	4	Hex Head Cap Screw, 5/16"-18 x 7/8"
22	GD19759	2	Module Bracket Mount
23	GD18901	2	Tap Block, Long
24	GA12563	1	Module Cover Assembly W/Lock Clamps
25	G10152	4	Hex Head Cap Screw, 5/8"-11 x 9"
26	GA12655	1	Implement Cable (16 Row)
27	GR0594	-	Brush
28	GA7851	2	Planter Harness W/Dust Caps, 24 Row (16 Connectors)
	GA8050	-	Planter Harness W/Dust Caps, 36 Row (18 Connectors)
	GD11993	-	Dust Cap
29	GA12166	-	Seed Tube W/Computerized Sensor (EdgeVac)
	GR1785	-	Sensor Only (EdgeVac)
	GA12636	-	Seed Tube (With Holes For Sensor Installation) (EdgeVac)
30	GA7859	1	Magnetic Distance Sensor Adapter (Analog To Digital)
31	GA12557	1	Planter Monitor Cable
32	GA14214	-	Seed Tube W/Computerized Sensor (Mechanical)
	GR1949	-	Sensor Only (Mechanical)
	GA10940	-	Seed Tube (W/Holes for Sensor Installation)(Mechanical)
A	GA6147	-	Magnetic Distance Sensor And Mounting Package (Items 9-14)

(CO1a/VI18/VI21/A12553/GR1916/GR1839/A12852/A12853)

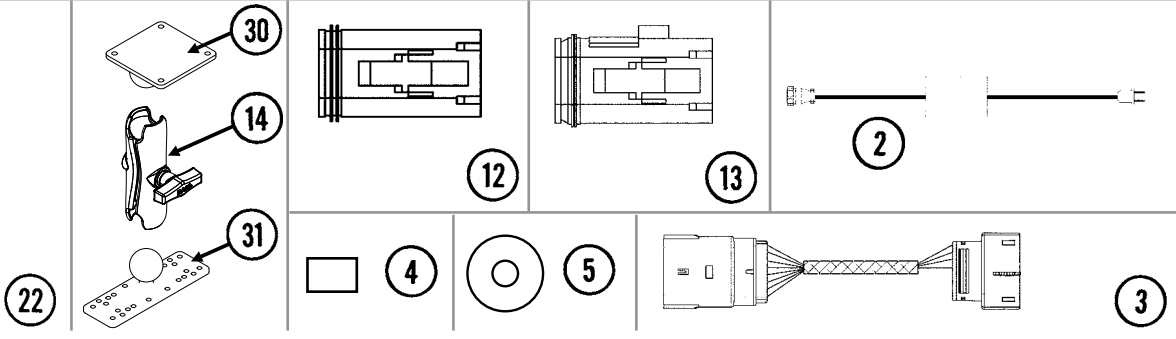
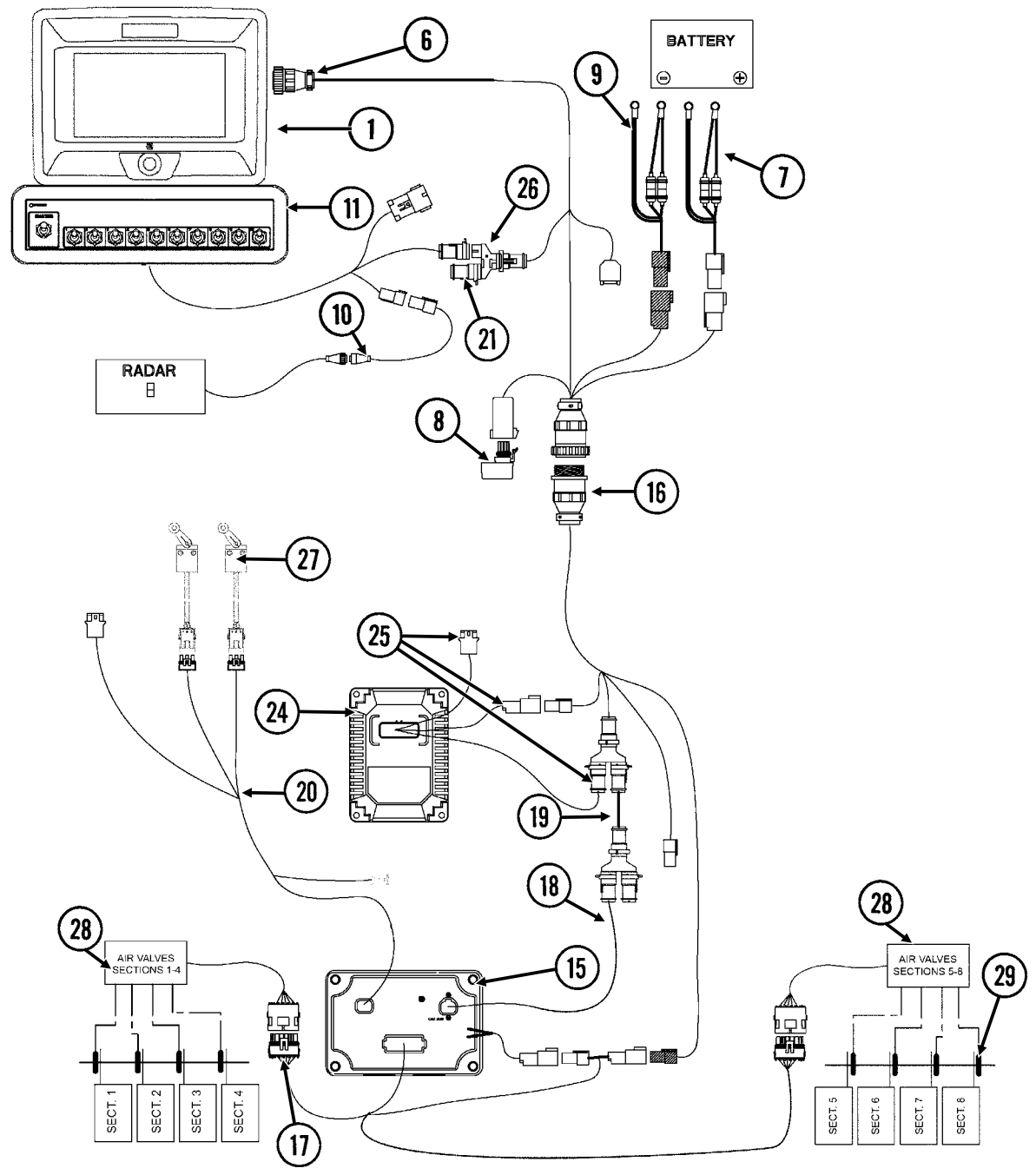

ITEM	PART NO.	QTY.	DESCRIPTION
1	GA13554	1	Cobalt Display
2	GA12852	1	Power Supply
3	GA13654	-	Adapter Cable
4	GR1835	1	Flash Card
5	GR1836	1	SMS CD
6	GA12551	1	Display Cable
7	GA12562	1	Power Cable
8	GA12540	1	Power Control Relay
9	GA12598	1	Seed Rate Power Cable
10	GA12596	1	Radar Adapter Cable
11	GA12539	1	Switch Box Module
12	GR1838	1	Dust Plug
13	GR1839	1	Dust Plug
14	GA12868	1	Ram Double Socket Arm
15	GA12537	1	Clutch Control Module
16	GA12555	1	Implement Cable (12 Row)
	GA12655	-	Implement Cable (16 Row)
17	GA13530	1	Clutch Control Cable
18	GA12558	1	Can Stub Cable, 8"
19	GA12559	1	Can Extension, 5"
20	GA13531	1	Implement Switch Extension Cable
21	GD18177	-	Terminator
22	GR1916	1	Switch Box Bracket
24	GA12538	-	Planter Monitor Module
25	GA12557	-	Planter Monitor Cable
26	GD18176	-	Y-Splice Connector
27	---	-	<a href="#">See "Shank Assembly, Seed Tube, and Depth Adjustment" on page P1</a>
28	---	-	<a href="#">See "Clutch Valve Assembly" on page P154</a>
29	---	-	<a href="#">See "Airline Fittings and Hoses, 24 Row 30" on page P119</a> <a href="#">See "Airline Fittings and Hoses, 36 Row 20" on page P120</a>
30	GD18408	1	Ram Vesa Base
31	GD18407	1	Ram Base

(VI50b/VI18/VI21/A12553/GR1916/GR1839/A12852/A12853)

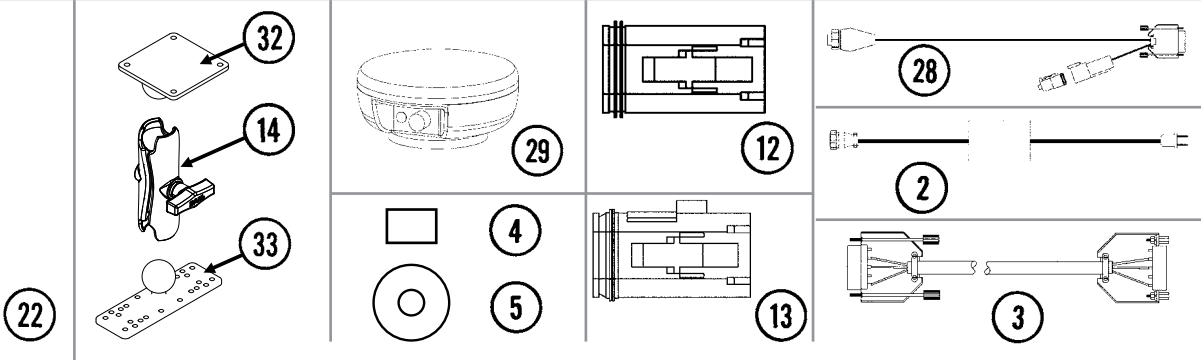
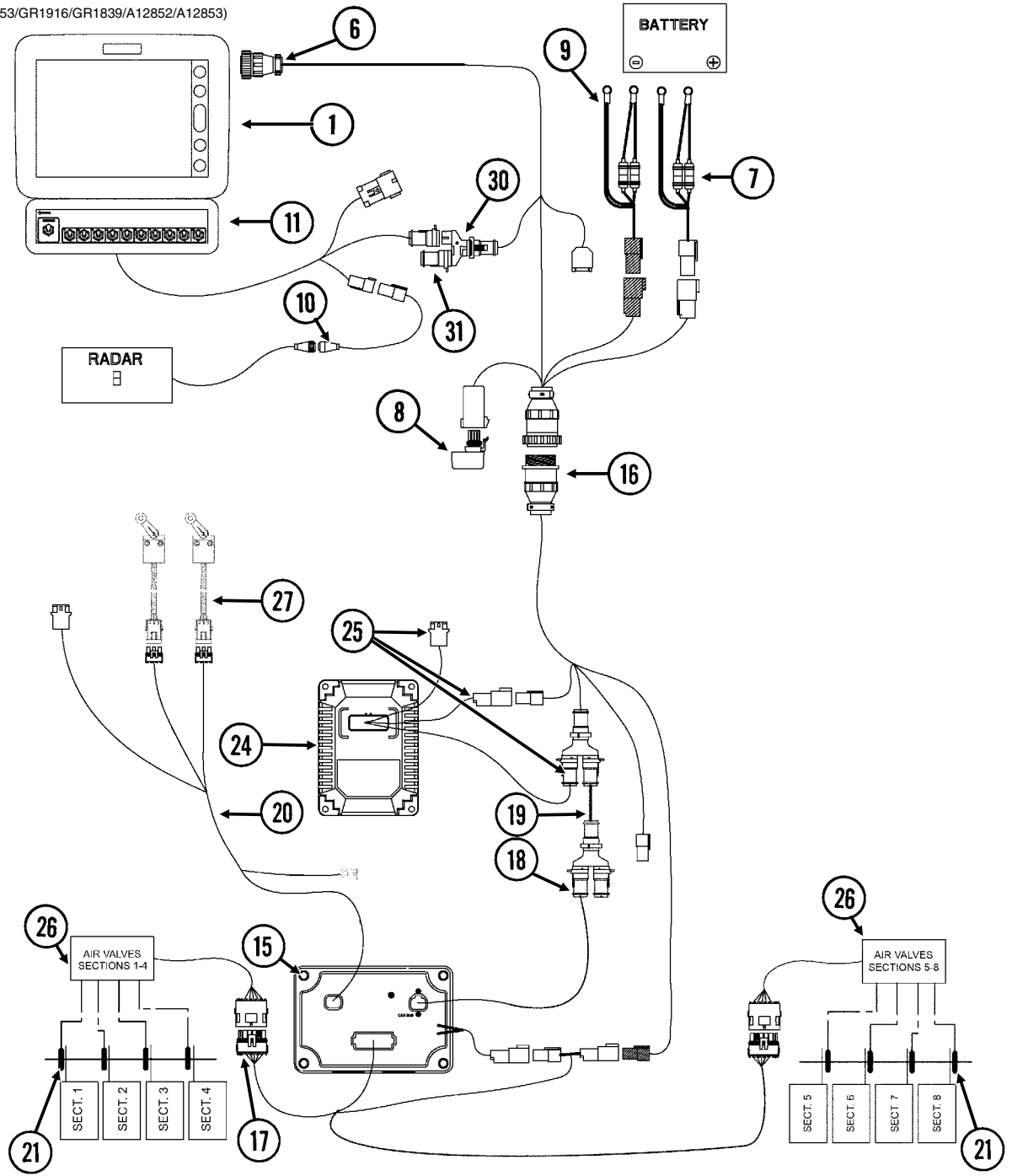

ITEM	PART NO.	QTY.	DESCRIPTION
1	GA12536	1	Vision Loaner (Display Only)
2	GA12852	1	Power Supply
3	GA12853	1	Null Modem Cable
4	GR1835	1	Flash Card
5	GR1836	1	SMS CD
6	GA12551	1	Display Cable
7	GA12562	1	Power Cable
8	GA12540	1	Power Control Relay
9	GA12598	1	Seed Rate Power Cable
10	GA12596	1	Radar Adapter Cable
11	GA12539	1	Switch Box Module
12	GR1838	1	Dust Plug
13	GR1839	1	Dust Plug
14	GA12868	1	Ram Double Socket Arm Assembly
15	GA12537	1	Clutch Control Module
16	GA12555	-	Implement Cable (12 Row)
	GA12655	-	Implement Cable (16 Row)
17	GA13530	1	Clutch Control Cable
18	GA12558	1	Can Stub Cable, 8"
19	GA12559	1	Can Extension, 5"
20	GA13531	1	Implement Switch Extension Cable
21	---	-	<a href="#">See "Airline Fittings and Hoses, 24 Row 30" on page P119</a> <a href="#">See "Airline Fittings and Hoses, 36 Row 20" on page P120</a>
22	GR1916	1	Switch Box Bracket
24	GA12538	-	Planter Monitor Module
25	GA12557	-	Planter Monitor Cable
26	---	-	<a href="#">See "Clutch Valve Assembly" on page P154</a>
27	---	-	<a href="#">See "Shank Assembly, Seed Tube, and Depth Adjustment" on page P1</a>
28	GA12553	1	GPS Cable
29	GA12552	1	GPS Antenna
30	GD18176	-	Y-Splice Connector
31	GD18177	-	Terminator
32	GD18408	1	Ram Vesa Base
33	GD18407	1	Ram Base
A	G8266X	-	Vision Display Package (Items 1-5)

(IP1296)

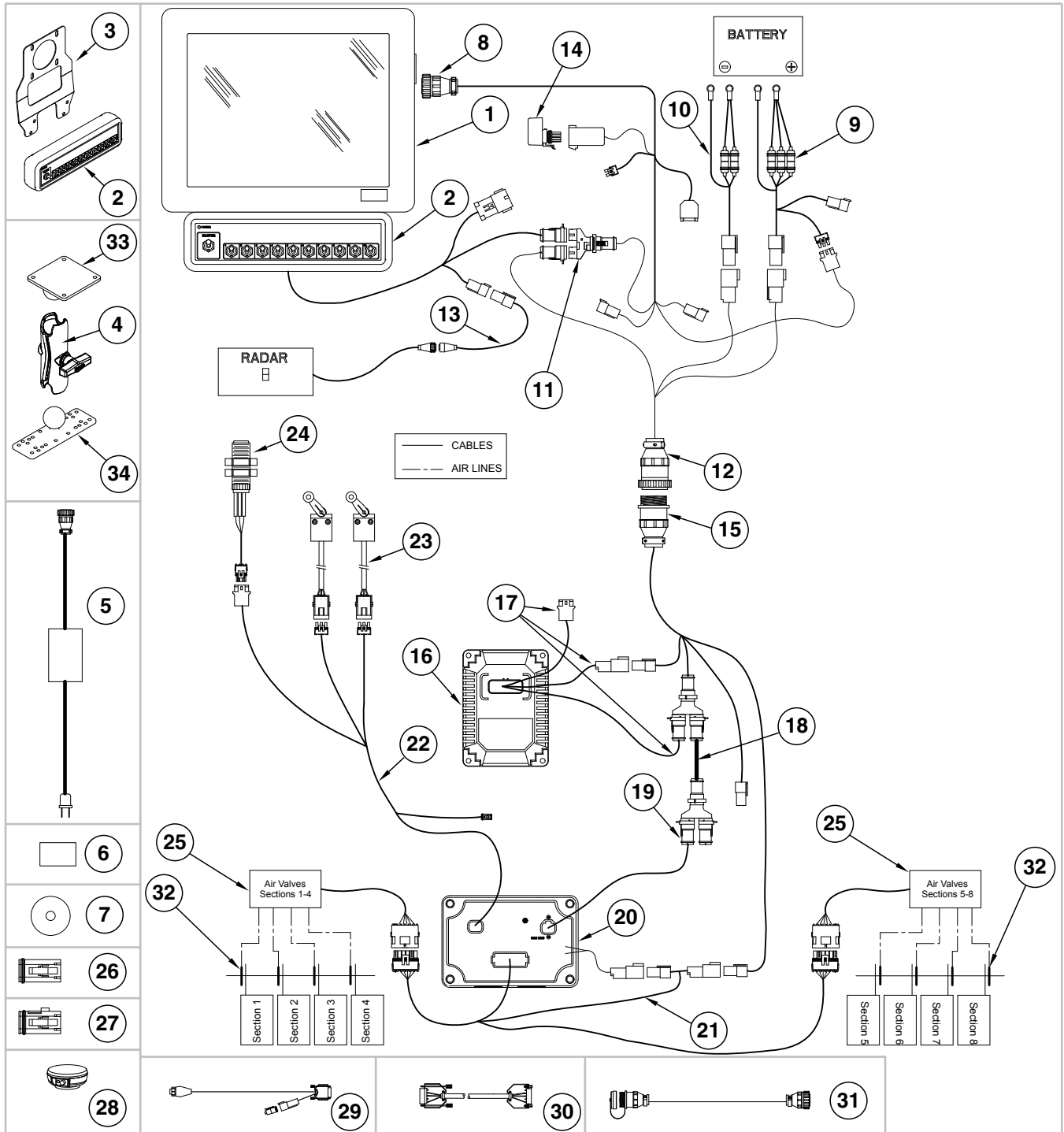

ITEM	PART NO.	QTY.	DESCRIPTION
1	GA14447	1	Integra Display
2	GA12539	1	Switch Box Module
3	GR1916	1	Switch Box Bracket
4	GA12868	1	Ram Double Socket Arm Assembly
5	GA12852	1	Power Supply
6	GA14449	1	Flash Drive
7	GR1836	1	SMS CD
8	GA14451	1	Integra Display Cable
9	GA14452	1	Power Cable
10	GA12598	1	Seed Rate Power Cable
11	GD18176	3	Y-Splice Connector
12	GA14450	1	Can Adapter Cable
13	GA12596	1	Radar Adapter Cable
14	GA12540	1	Power Control Relay
15	GA13044	1	Implement Cable, 16 Row
16	GA12538	1	Planter Monitor Module
17	GA12557	1	Planter Monitor Cable
18	GA12567	1	Can Extension Cable, 4"
19	GA12566	1	Can Stub Cable, 6"
20	GA12537	1	Clutch Control Module
21	GA12556	1	Seed Command Cable
22	GA13047	1	Implement Switch Extension Cable
23	---		<a href="#">See "Shank Assembly, Seed Tube, and Depth Adjustment" on page P1</a>
24	GA13204	1	Hall Effect Sensor
25	---	-	<a href="#">See "Clutch Valve Assembly" on page P154</a>
26	GR1838	1	Dust Plug
27	GR1839	1	Dust Plug
28	GA12552	1	GPS Antenna
29	GA12553	1	GPS Cable
30	GA12853	1	Null Modem Cable
31	GA13562	1	Cable Extension, 180"
32	---	-	<a href="#">See "Airline Fittings and Hoses, 24 Row 30"" on page P119</a> <a href="#">See "Airline Fittings and Hoses, 36 Row 20"" on page P120</a>
33	GD18408	1	Ram Vesa Base
34	GD18407		Ram Base

(FF124a)

**40 Tooth Drive Sprocket And  
18 Tooth Driven Sprocket**

**Model NGP-6055  
Piston Pump**

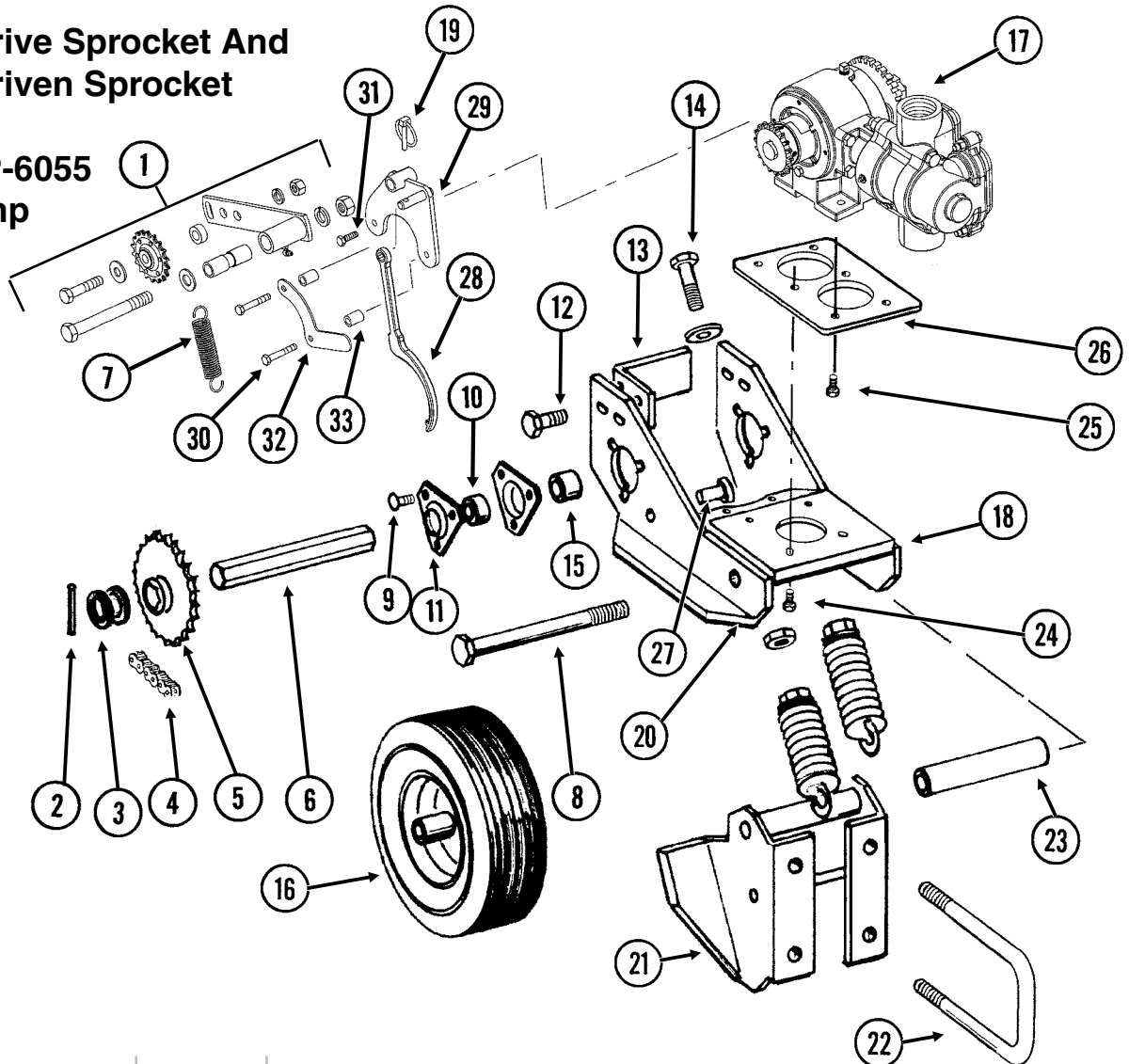

ITEM	PART NO.	QTY. (Per Assy.)	DESCRIPTION
1	GA12597	1	Idler W/Sprocket, Bushing, Spacer And Hardware
	GA7154	-	Sprocket W/Bearing, 18 Tooth
	GD7889	-	Bushing, 1" O.D. x 9/16" I.D x 7/16" Long
	G10581	-	Hex Head Cap Screw, 1/2"-13 x 2 1/4"
	G11389	-	Flat Washer, 1/2" SAE
	G10228	-	Lock Washer, 1/2"
	G10102	-	Hex Nut, 1/2"-13
	G10011	-	Hex Head Cap Screw, 5/8"-11 x 5 1/2"
	G11391	-	Flat Washer, 5/8" SAE
	G10230	-	Lock Washer, 5/8"
	G10104	-	Hex Nut, 5/8"-11
	GD10254	-	Spacer, 2 3/4"
	GA7248	-	Idler Arm
	G10779	-	Grease Fitting, 90°, 1/4"-28
2	G10602	2	Spring Pin, 1/4" x 1 1/2"
3	G10233	5	Machine Bushing, 1", 10 Gauge
4	G3310-91	1	Chain, No. 40, 91 Pitch Including Connector Link And Offset Link
	GR0912	-	Connector Link, No. 40
	GR0911	-	Offset Link, No. 40

ITEM	PART NO.	QTY. (Per Assy.)	DESCRIPTION
5	GA7180	1	Sprocket, 40 Tooth
6	GD6825-11.25	1	Hex Shaft, 7/8" x 11 1/4" (2 Holes)
7	GD5857	1	Spring
8	G10093	1	Hex Head Cap Screw, 5/8"-11 x 8 1/2"
	G10230	1	Lock Washer, 5/8"
	G10104	1	Hex Nut, 5/8"-11
9	G10302	6	Carriage Bolt, 5/16"-18 x 7/8"
	G11386	6	Flat Washer, 5/16" SAE
	G10232	6	Lock Washer, 5/16"
	G10106	6	Hex Nut, 5/16"-18
10	G2100-03	2	Bearing, 7/8" Hex Bore, Spherical
11	G3400-01	4	Flangette
12	G10004	2	Hex Head Cap Screw, 3/8"-16 x 1 1/4"
	G11387	4	Flat Washer, 3/8" SAE
	G10229	2	Lock Washer, 3/8"
	G10101	2	Hex Nut, 3/8"-16
13	GD11556	1	Scraper
14	G10053	2	Hex Head Cap Screw, 1/2"-13 x 2 1/2"
	G11389	2	Flat Washer, 1/2" SAE
	G10102	2	Hex Nut, 1/2"-13
15	GD10200	2	Sleeve, 3/4" Long
16	GA5090	-	Tire And Rim Assembly (Specify Brand*)
	GD5753	1	Tire, 4.10" x 6" (Specify Brand*)
	GD5752	1	Inner Tube
17	---	-	<a href="#">See "Liquid Fertilizer Piston Pump, NGP-6055" on page P185</a>
18	GA7246	1	Base Mount
19	GD2558	1	Lynch Pin, 1/4"
20	GA2068	2	Spring W/Plug
21	GA7245	1	Pump Mount W/Grease Fitting
	G10641	-	Grease Fitting, 1/8" NPT
22	GD11289	2	U-Bolt, 7" x 4" x 5/8"-11
	G10230	4	Lock Washer, 5/8"
	G10104	4	Hex Nut, 5/8"-11
23	GD10244-01	1	Sleeve, 7 1/16"
24	G10062	4	Hex Head Cap Screw, 3/8"-16 x 3"
	G10229	4	Lock Washer, 3/8"
	G10101	4	Hex Nut, 3/8"-16
25	G10003	4	Hex Head Cap Screw, 3/8"-16 x 1 1/2"
	G11387	4	Flat Washer, 3/8" SAE
	GR1122	4	Mounting Pad
	G10229	4	Lock Washer, 3/8"
	G10101	4	Hex Nut, 3/8"-16
26	GD11554	1	Pump Mount
27	G10478	2	Clevis Pin, 5/16" x 1"
	G10409	2	Retaining Ring, 5/16"
28	---	-	<a href="#">See "Liquid Fertilizer Piston Pump, NGP-6055" on page P185</a>
29	GA12616	1	Idler Mounting Bracket
30	G10041	2	Hex Head Cap Screw, 5/16"-18 x 2"
31	G10019	1	Hex Head Cap Screw, 5/16"-18 x 1"
32	GD18065	1	Guide
33	GD2971-17	2	Sleeve, 7/8" Long

\* Specific brand requests will be supplied only as available from current Kinze Repair Parts stock. If a specific brand requested is not in stock, the brand available will be supplied. Different brand tires may have different diameters. Change in tire brand may affect rates. Field checks are recommended after any change in contact tires

(TWL317a)

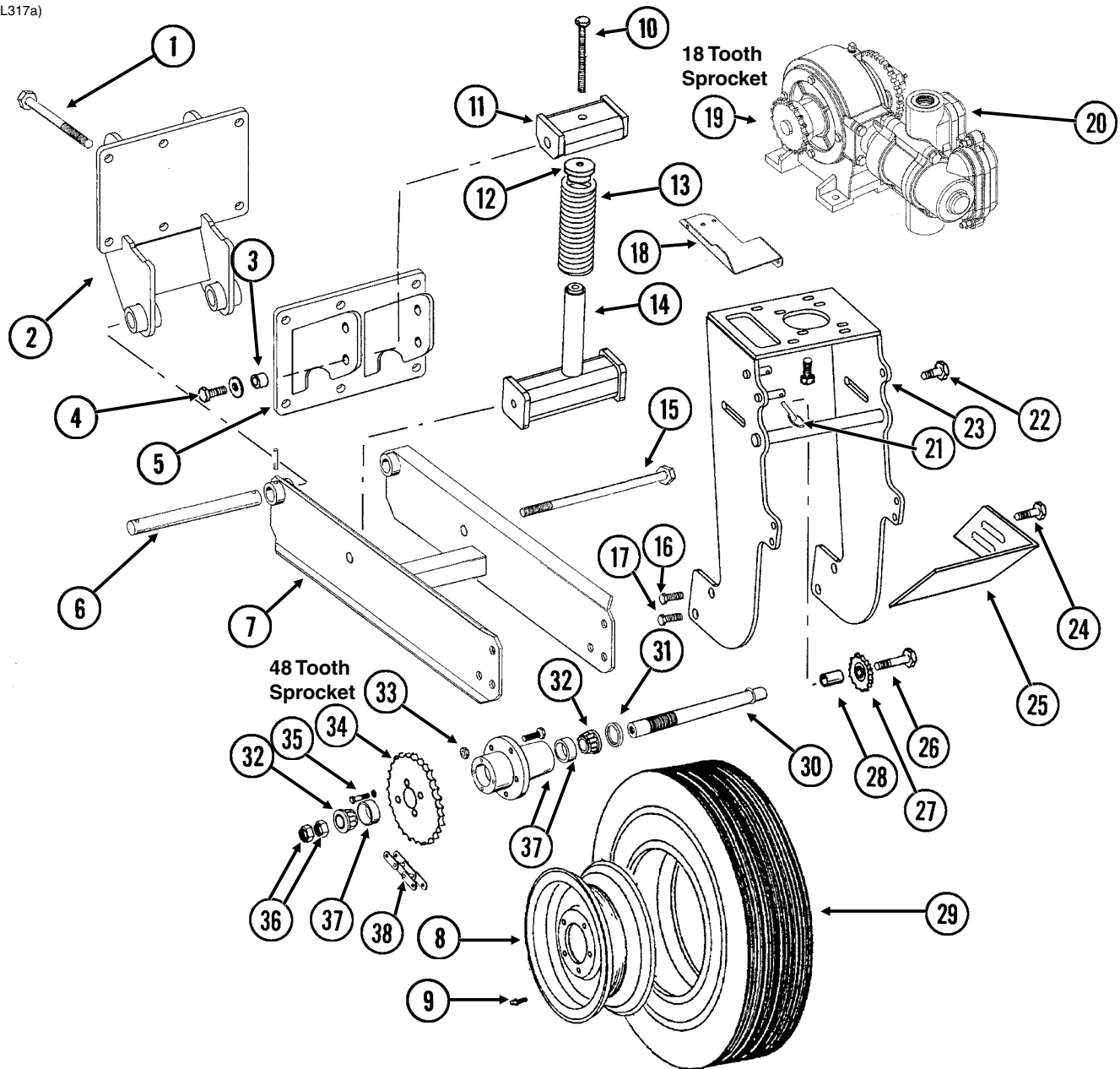

ITEM	PART NO.	QTY.	DESCRIPTION
1	G10152	6	Hex Head Cap Screw, 5/8"-11 x 9"
	G10230	6	Lock Washer, 5/8"
	G10104	6	Hex Nut, 5/8"-11
2	GA10355	1	Wheel Arm Mount
3	GB0218	2	Bushing, 2 <sup>1</sup> / <sub>32</sub> " I.D. x 7/8" O.D. x 1 <sup>19</sup> / <sub>32</sub> " Long
4	G10005	2	Hex Head Cap Screw, 5/8"-11 x 1 <sup>3</sup> / <sub>4</sub> "
	G11391	2	Flat Washer, 5/8" SAE
	G10107	2	Lock Nut, 5/8"-11
5	GA9712	1	Spring Mount
6	GD2681	1	Pin, 1 <sup>1</sup> / <sub>4</sub> " x 13 <sup>1</sup> / <sub>2</sub> "
	G10460	2	Cotter Pin, 1/4" x 2"
7	GA10621	1	Arm W/Grease Fittings
	G10641	2	Grease Fitting, 1/8" NPT

ITEM	PART NO.	QTY.	DESCRIPTION
8	GA0241	1	Wheel, 5" x 15"
9	GD1166	1	Valve Stem
10	G10012	1	Hex Head Cap Screw, 5/8"-11 x 6 1/2"
	G11391	1	Flat Washer, 5/8" SAE
11	GA10908	1	Spring Mount
12	GB0196	1	Washer
13	GD7831	1	Compression Spring
14	GA10907	1	Spring Guide
15	G11122	1	Hex Head Cap Screw, 5/8"-11 x 12"
	G10107	1	Lock Nut, 5/8"-11
16	G10026	2	Hex Head Cap Screw, 3/4"-10 x 2"
	G10231	2	Lock Washer, 3/4"
17	G11042	2	Hex Head Cap Screw, 3/4"-10 x 1 3/4"
	G10231	2	Lock Washer, 3/4"
	G10105	2	Hex Nut, 3/4"-10
18	GD13744	1	Hose Holder
19	GR1146	1	Sprocket, 18 Tooth
20	---	-	<a href="#">See "Liquid Fertilizer Piston Pump, NGP-7055" on page P187</a>
21	GD2558	1	Lynch Pin, 1/4"
22	G10007	2	Hex Head Cap Screw, 5/8"-11 x 1 1/2"
	G11391	2	Flat Washer, 5/8" SAE
	G10230	2	Lock Washer, 5/8"
	G10104	2	Hex Nut, 5/8"-11
23	GA10894	1	Pump Mount
24	G10017	2	Hex Head Cap Screw, 1/2"-13 x 1 1/2"
	G11389	2	Flat Washer, 1/2" SAE
	G10228	2	Lock Washer, 1/2"
	G10102	2	Hex Nut, 1/2"-13
25	GD13328	1	Scraper
26	G10013	1	Hex Head Cap Screw, 5/8"-11 x 3 1/2"
	G11391	1	Flat Washer, 5/8" SAE
	G10230	1	Lock Washer, 5/8"
	G10104	1	Hex Nut, 5/8"-11
27	GA0262	1	Idler Sprocket W/Bearing, 15 Tooth
28	GD7817-05	1	Spacer, 1 1/16" I.D. x 1 1/4" Long
29	GD0844	1	Tire, 7.60" x 15", 8 Ply (Specify Brand*)
30	GA2559	1	Spindle
31	GA0252	2	Seal
32	GA0251	2	Bearing
33	GR0267	5	Lug Nut, 1/2"-20
34	G2500-84	1	Sprocket, 48 Tooth
35	G10019	4	Hex Head Cap Screw, 5/16"-18 x 1"
	G10232	4	Lock Washer, 5/16"
36	GD0831	2	Shoulder Nut, 1 1/4"-12 UNF-2A
37	GA0547	1	Hub W/Cups And Studs, 5 Bolt
	GR0190	2	Cup
	GR0204	5	Stud
38	G3200-63	1	Chain, No. 2050, 63 Pitch Including Connector Link
	GR0195	1	Connector Link, No. 2050
	GR0200	1	Offset Link, No. 2050

\*Specific brand requests will be supplied only as available from current Kinze Repair Parts stock. If a specific brand requested is not in stock, the brand available will be supplied. Different brand tires may have different diameters. Change in tire brand may affect rates. Field checks are recommended after any change in tires.

(FF84c/FF84cc)

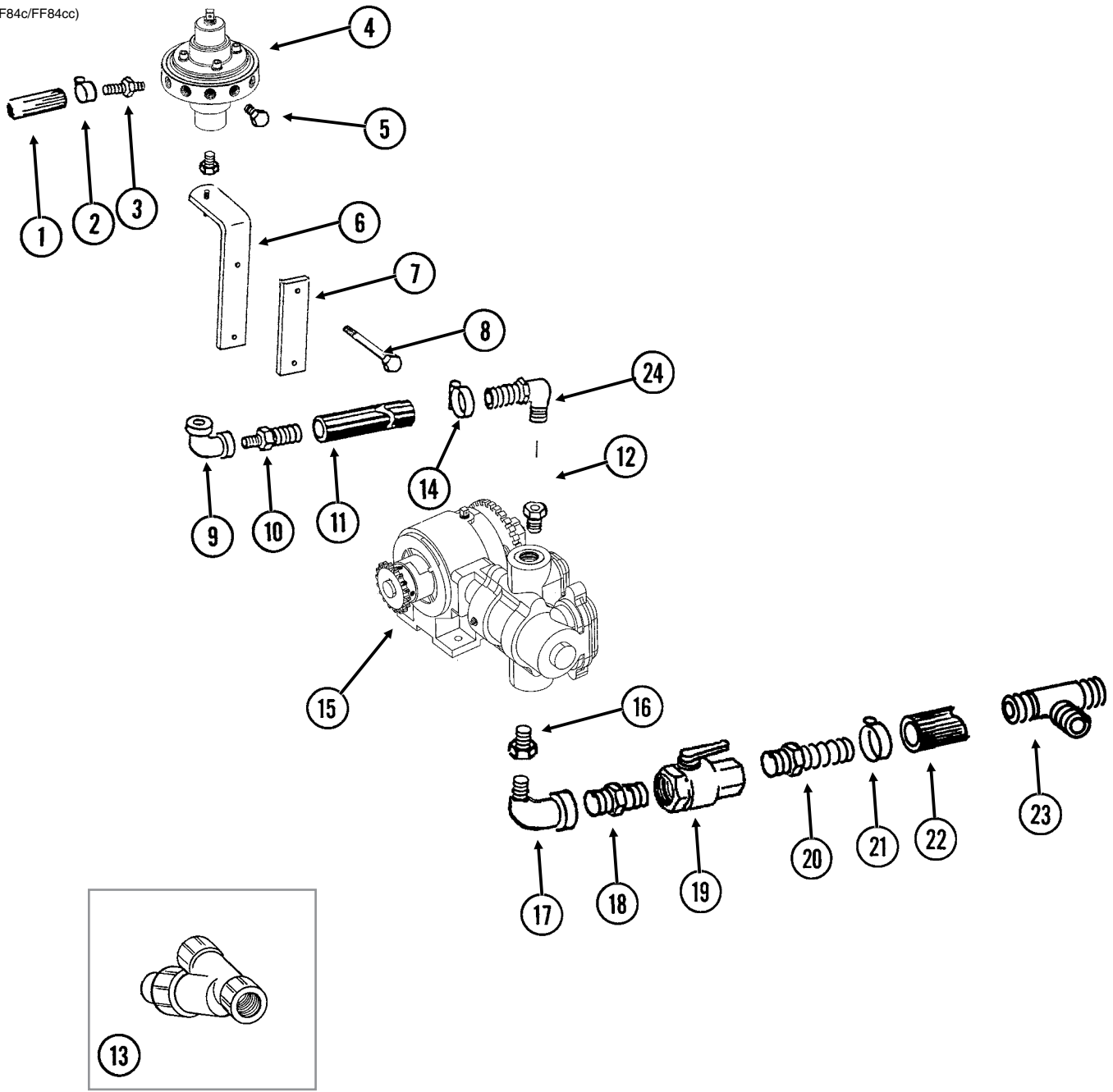

ITEM	PART NO.	QTY.	DESCRIPTION
1	G4301-08	-	Hose, 3/8" x 250', 24 And 36 Row
2	G10681	-	Hose Clamp, No. 6
3	GD11700	18-24	Adapter, 1/4" NPT To 3/8" Barb
4	---	-	<a href="#">See "Liquid Fertilizer Piston Pump Flow Divider" on page P189</a>
5	G10292	-	Pipe Plug, 1/4" NPT
6	GA6527	2	Mount, 3/4" NPT
7	GD10248	2	Bar
8	G10152	2	Hex Head Cap Screw, 5/8"-11 x 9"
	G10230	2	Lock Washer, 5/8"
	G10104	2	Hex Nut, 5/8"-11
9	G10733	2	Elbow, 90°, 3/4" Female NPT
10	G10734	2	Adapter, 3/4" NPT To Barb
11	G4205-10	2	Hose, 3/4" x 200"
12	G11237	2	Reducing Bushing, 1 1/2" Male NPT To 3/4" Female
13	GA3893	1	Strainer Complete
	GR0880	-	Screen, No. 40 Mesh
	GR0881	-	Gasket
	GR0882	-	Y-Body
	GR0883	-	End Cap
14	G10278	-	Hose Clamp, No. 16
15	---	-	<a href="#">See "Liquid Fertilizer Piston Pump, NGP-6055" on page P185</a> <a href="#">See "Liquid Fertilizer Piston Pump, NGP-7055" on page P187</a>
16	G10615	2	Reducing Bushing, 1 1/2" Male NPT To 1 1/4" Female
17	G10887	2	Elbow, 90°, 1 1/4" Male NPT To Female
18	G10619	2	Close Nipple, 1 1/4" NPT
19	GA4976	2	Shutoff Valve, 1 1/4" NPT
	GR1015	-	Body O-Ring
	GR1016	-	Stem O-Ring
	GR1017	-	Teflon Seat
	GR1018	-	Ball
	GR1019	-	Handle
20	G10626	4	Adapter, 1 1/4" NPT To Barb
21	G10674	2	Hose Clamp, No. 24
22	G4200-01	1	Hose, 1 1/4" x 22'
23	G10633	1	Tee, 1 1/4" Barb
24	G10917	2	Elbow, 90°, 3/4" NPT To Barb

(A12335a/GR1808)

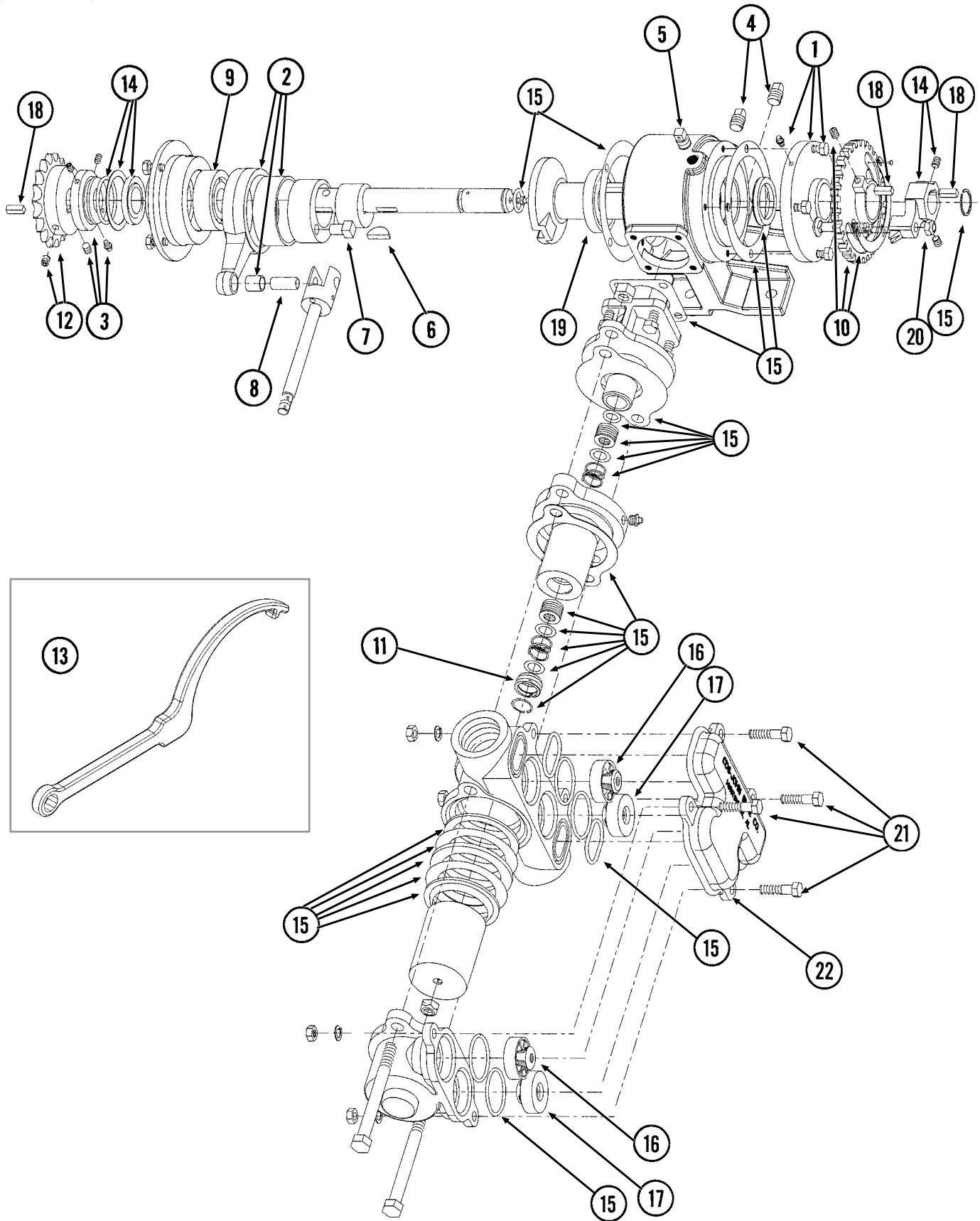

ITEM	PART NO.	QTY.	DESCRIPTION
1	GR1804	1	Flange Cover Assembly
	G10991	4	Hex Head Cap Screw, 5/16"-18 x 7/8"
2	GR1802	1	Connecting Rod Assembly
3	GR1801	1	Spacer Assembly
	G10693	3	Hex Socket Head Set Screw, 5/16"-18 x 3/8"
4	GR1123	2	Plug
5	GR1543	1	Vent Plug
6	GR1112	1	Woodruff Key
7	GR1120	1	Eccentric Pin
8	GR1124	1	Pin
9	GR1104	1	Bearing
10.	GR1805	1	Setting Hub Assembly
11	GR1134	1	Stuffing Box Insert
12	GR1389	1	Sprocket, 18 Tooth
13	GR1808	1	Adjustment Wrench
14	GR1806	1	Setting Pointer Assembly
15	GR1795	1	Repair Kit, Includes: (6) Gaskets, (9) O-Rings, (4) Washers, (1) Retaining Ring, (2) Oil Seals, (1) Snap Ring, (1) Thrust Washer, (1) Rod Bushing, (2) Flange Plunger Packings, (2) Packing Springs, (2) Rod Vee Packing Sets
16	GR1799	2	Discharge Valve Assembly
17	GR1797	2	Suction Valve Assembly
18	GR1118	3	Setting Arm Key
19	GR1116	1	Bearing
20	G10306	1	Carriage Bolt, 3/8"-16 x 2"
	G10108	1	Lock Nut, 3/8"-16
21	G10003	4	Hex Head Cap Screw, 3/8"-16 x 1 1/2"
	G11387	4	Flat Washer, 3/8" SAE
	G10229	4	Lock Washer, 3/8"
	G10101	4	Hex Nut, 3/8"-16
22	GR2003	1	Valve Cover
A	GA12330	-	Piston Pump Complete W/18 Tooth Sprocket (Model NGP-6055)

(A12335a/GR1808)

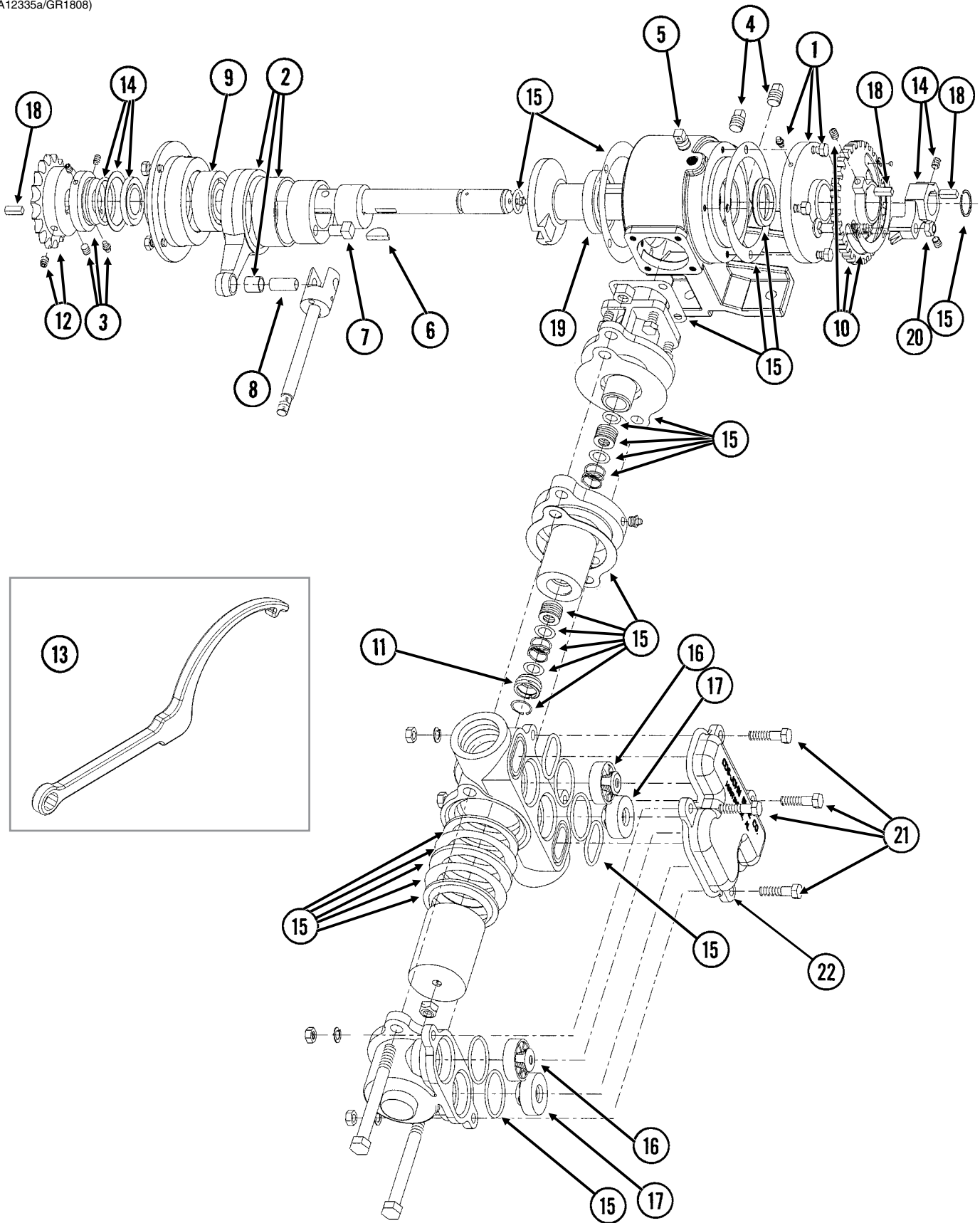

ITEM	PART NO.	QTY.	DESCRIPTION
1	GR1804	1	Flange Cover Assembly
	G10991	4	Hex Head Cap Screw, 5/16"-18 x 7/8"
2	GR1803	1	Connecting Rod Assembly
3	GR1801	1	Spacer Assembly
	G10693	3	Hex Socket Head Set Screw, 5/16"-18 x 3/8"
4	GR1123	2	Plug
5	GR1543	1	Vent Plug
6	GR1112	1	Woodruff Key
7	GR1120	1	Eccentric Pin
8	GR1124	1	Pin
9	GR1104	1	Bearing
10	GR1805	1	Setting Hub Assembly
11	GR1134	1	Stuffing Box Insert
12	GR1146	1	Sprocket, 18 Tooth
13	GR1808	1	Adjustment Wrench
14	GR1806	1	Setting Pointer Assembly
15	GR1796	1	Repair Kit, Includes: (6) Gaskets, (9) O-Rings, (4) Washers, (1) Retaining Ring, (2) Oil Seals, (1) Snap Ring, (1) Thrust Washer, (1) Rod Bushing, (2) Flange Plunger Packings, (2) Packing Springs, (2) Rod Vee Packing Sets
16	GR1800	2	Discharge Valve Assembly
17	GR1798	2	Suction Valve Assembly
18	GR1118	3	Setting Arm Key
19	GR1116	1	Bearing
20	G10306	1	Carriage Bolt, 3/8"-16 x 2"
	G10108	1	Lock Nut, 3/8"-16
21	G10003	4	Hex Head Cap Screw, 3/8"-16 x 1 1/2"
	G11387	4	Flat Washer, 3/8" SAE
	G10229	4	Lock Washer, 3/8"
	G10101	4	Hex Nut, 3/8"-16
22	GR2011	1	Valve Cover, NPG-7055
A	GA12335	-	Piston Pump Complete W/18 Tooth Sprocket (Model NGP-7055)

(FRTZ202c)

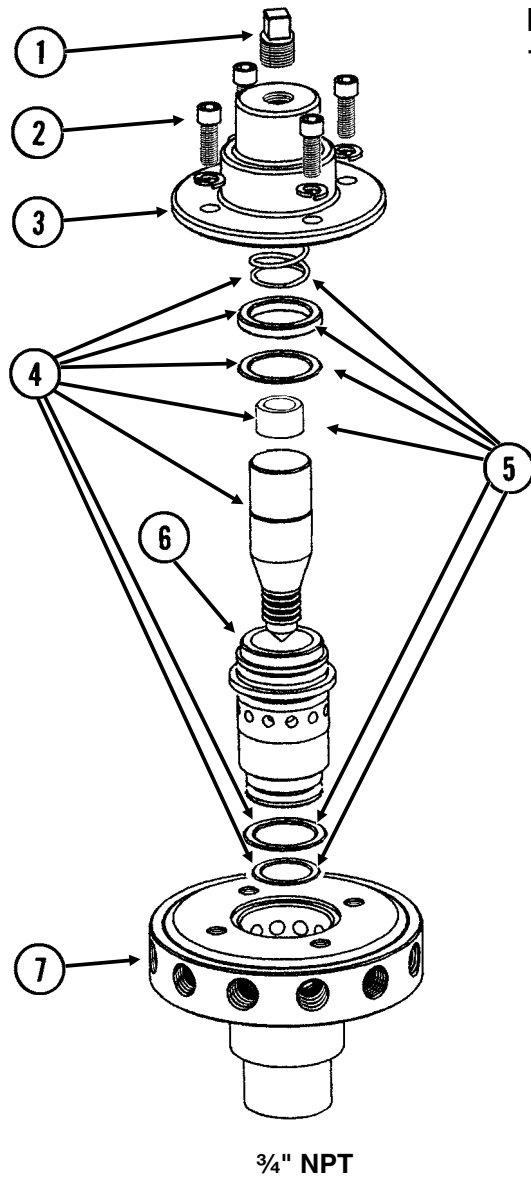

**Model FD-1200 Flow Divider,  
12 Outlet**

ITEM	PART NO.	QTY.	DESCRIPTION
1	GR1543	1	Vent Plug
2	GR1542	4	Hex Socket Head Screw, 1/4"-20 x 3/4", Stainless Steel
	GR1541	4	Lock Washer, 1/4", Stainless Steel
3	GR1540	1	Cap
4	GR1544	1	Needle Assembly W/Seal Kit (Item 5)
5	GR1545	1	Seal Kit, Includes: (3) O-Rings, (1) Seal, (1) Spring, (1) Stainless Steel Sleeve
6	GR1535	1	Sleeve
7	GR1533	1	Body (12 Outlets)
A	GA8931	1	Liquid Fertilizer Piston Pump Flow Divider Complete, 12 Outlet (Model FD-1200)

**This page left blank intentionally.**

(IP1152)

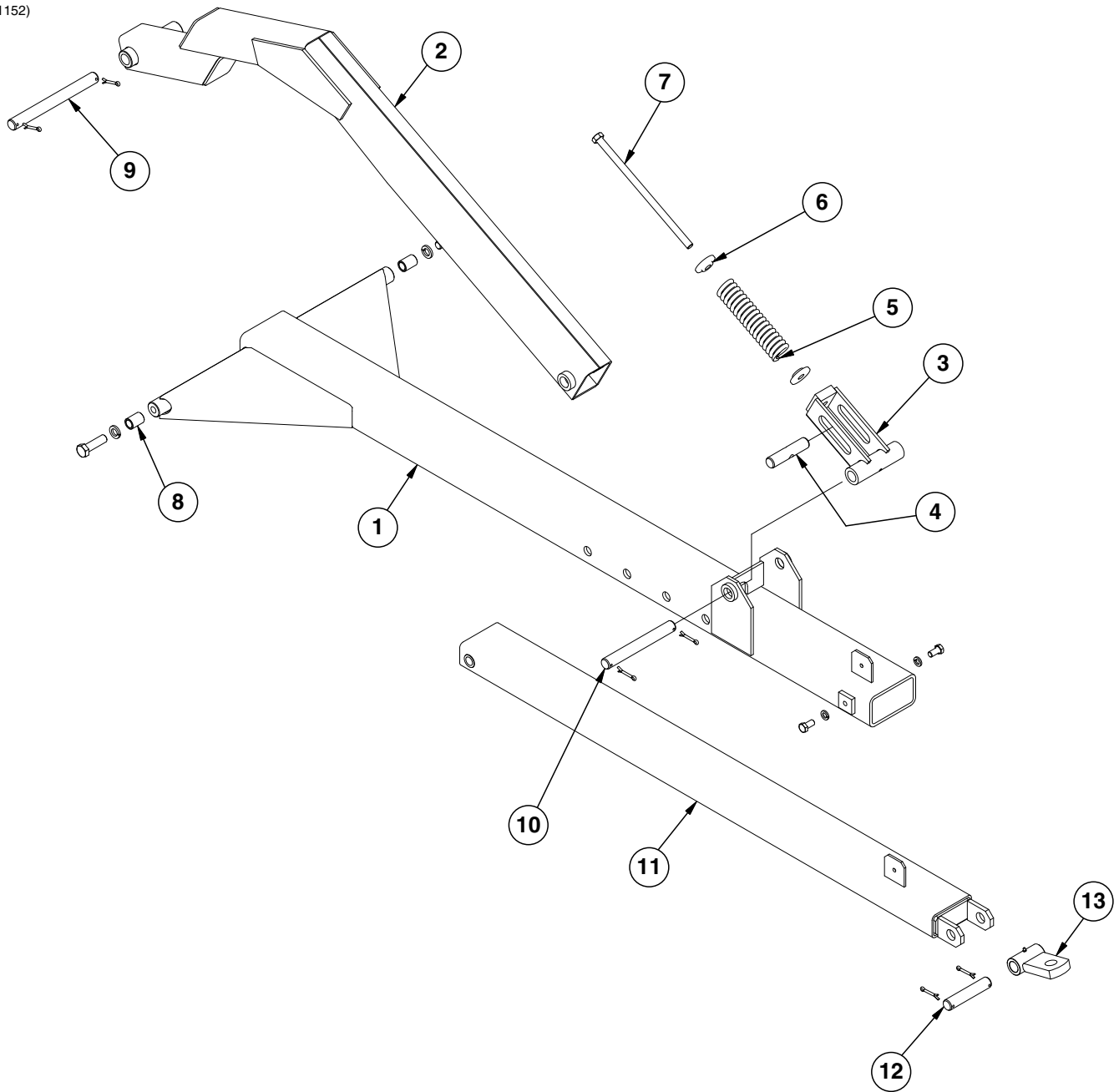

ITEM	PART NO.	QTY.	DESCRIPTION
1	GA7254	1	Front Hitch
	G10055	2	Hex Head Cap Screw, 5/8"-11 x 1 1/4" (Stop Bolt)
	G10230	2	Lock Washer, 5/8"
2	GA9408	1	Top Link W/Grease Fitting
3	GA7258	1	Side Link W/Grease Fitting
4	GD10296	1	Pin, 1 1/4" x 5 1/2"
5	GD10273	1	Compression Spring
6	GB0213	2	Spring Seat
7	GD7907	1	Special Bolt
8	GD10297	2	Bushing, 1 3/4"
	G10441	2	Hex Head Cap Screw, 7/8"-9 x 3", Grade 8
	G10330	2	Lock Washer, 7/8"
9	GD3547	1	Pin, 1 1/4" x 12 3/4"
	G10460	2	Cotter Pin, 1/4" x 2"
10	GD1702	1	Pin, 1 1/4" x 10 1/4"
	G10460	2	Cotter Pin, 1/4" x 2"
11	GA7256	1	Rear Hitch
12	GD8839	1	Pin, 1 1/4" x 6 1/4"
	G10460	2	Cotter Pin, 1/4" x 2"
13	GA6177	1	Clevis W/Grease Fitting

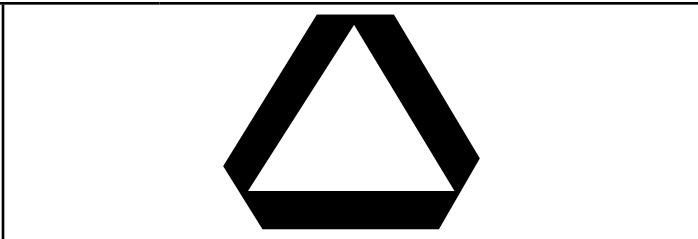
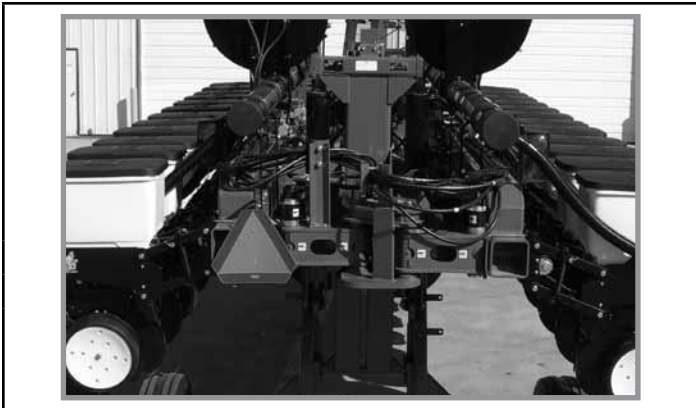

Part No.: GD2199  
 Description: SMV Sign  
 Quantity: 1

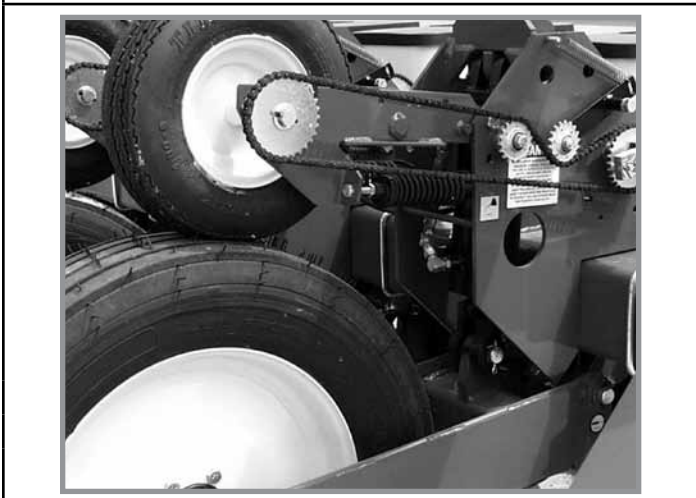

Part No.: G7100-89  
 Description: Decal, Danger  
 Quantity: 4

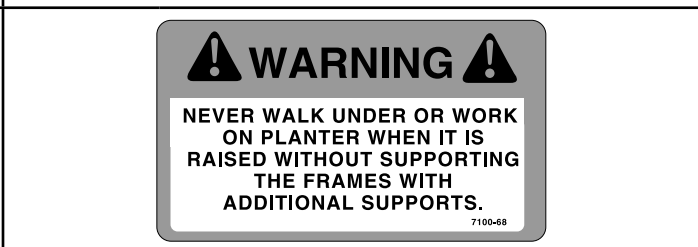

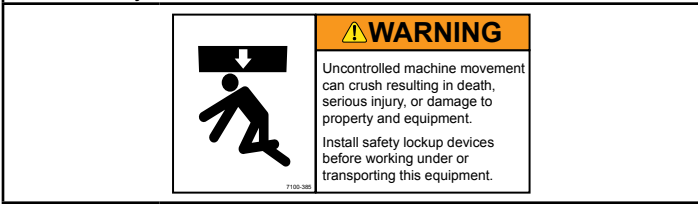

Part No.: G7100-68  
 Description: Decal, Warning (Prior to 2012 Production)  
 Quantity: 1

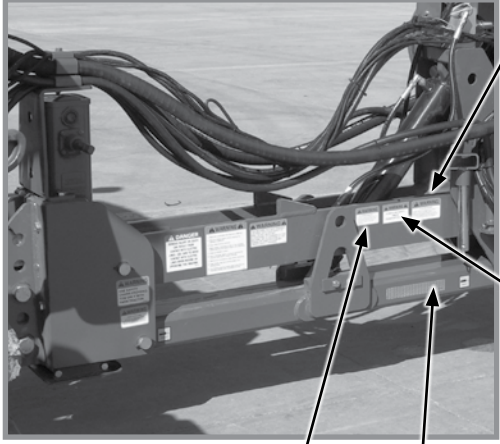
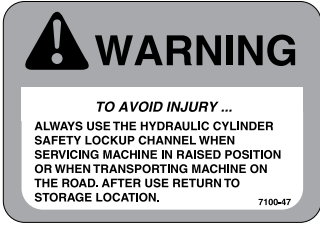
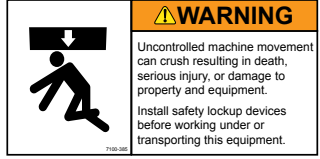

Part No.: G7100-385  
 Description: Decal, Warning (2012 Production and On)  
 Quantity: 1

	<p>Part No.: G7100-117 Description: Decal, Danger Quantity: 1</p>
	<p>Part No.: G7100-46 Description: Decal, Warning Quantity: 1</p>
	<p>Part No.: G7100-90 Description: Decal, Warning Quantity: 1</p>
<p>Part No.: G7100-302 Description: Decal, Warning Quantity: 1</p>	
<p>Part No.: G7100-197 Description: Decal, Warning Quantity: 1</p>	

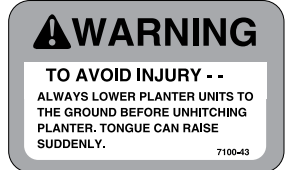
 <p>G7100-47 or G7100-385</p> <p>G7100-02</p> <p>G7100-43</p> <p>G7100-259</p>	
	<p>Part No.: G7100-47 Description: Decal, Warning (Prior to 2012 Production) Quantity: 1</p>
	
	<p>Part No.: G7100-385 Description: Decal, Warning (2012 Production and on) Quantity: 1</p>
	
	<p>Part No.: G7100-02 Description: Decal, Warning Quantity: 1</p>
	
<p>Part No.: G7100-259 Description: Reflective Decal, Amber, 1 1/2" x 9", Rectangular Quantity: 2 (one located on each side of hitch)</p>	
	
<p>Part No.: G7100-43 Description: Decal, Warning Quantity: 1</p>	

<p>G7100-83 or G7100-385</p> <p>G7100-42 or G7100-397</p>	
	<p>Part No.: G7100-83 Description: Decal, Warning (Prior to 2012 Production) Quantity: 2 (One Per Marker)</p>
	<p>Part No.: G7100-385 Description: Decal, Warning (2012 Production and on) Quantity: 1</p>
	<p>Part No.: G7100-42 Description: Decal, Warning (Prior to 2012 Production) Quantity: 4 (2 Per Row Marker)</p>
	<p>Part No.: G7100-397 Description: Decal, Warning (2012 Production and on) Quantity: 4 (2 Per Row Marker)</p>

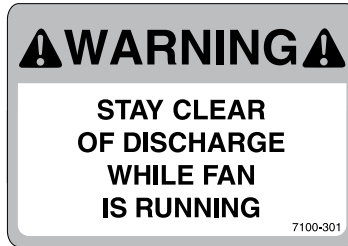

Part No.: G7100-301  
 Description: Decal, Warning (Prior to 2012 Production)  
 Quantity: 4 (One On Each Side Of Fan)



Part No.: G7100-392  
 Description: Decal, Caution (2012 Production and on)  
 Quantity: 4 (One On Each Side Of Fan)



24 Row 30"



Part No.: G7100-266  
 Description: Decal, Danger (Prior to 2012 Production)  
 Quantity: 2 (Located on each stair)

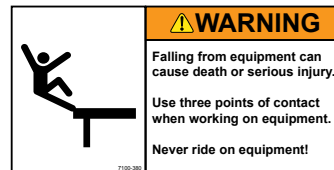

Part No.: G7100-380  
 Description: Decal, Warning (2012 Production and On)  
 Quantity: 2 (Located on each stair)



36 Row 20"

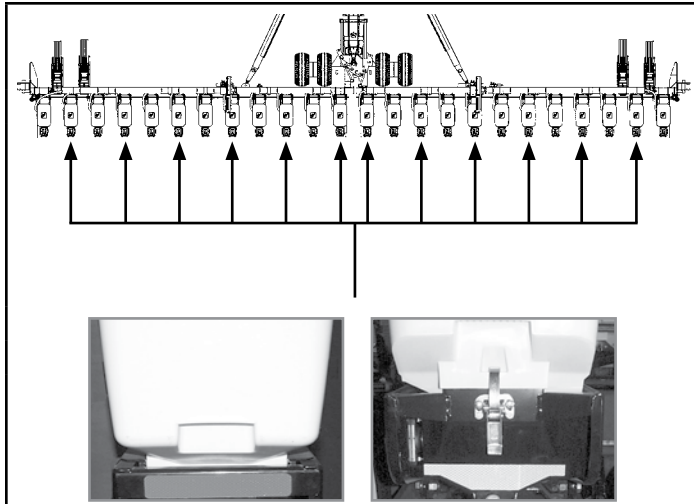

Note: 12 decals are used on 24 Row 30" and 18 on 36 Row 20"



Part No.: G7100-259

Description: Reflective Decal, Amber, 1½" x 9", Rectangular  
 Quantity: 1 (Per Row Unit - Located On The Granular Chemical Hopper Panel Extension on Every Other Row Unit Beginning On The 2nd row unit in on the L.H. end of the Planter) (With Optional Granular Chemical)

Part No.: G7100-262

Description: Reflective Decal, Amber, 1¾" x 9", Die-Cut  
 Quantity: 1 (Per Row Unit - Located On The Hopper Support on Every Other Row Unit Beginning on the 2nd row unit in on the L.H. end of the Planter) (Standard)

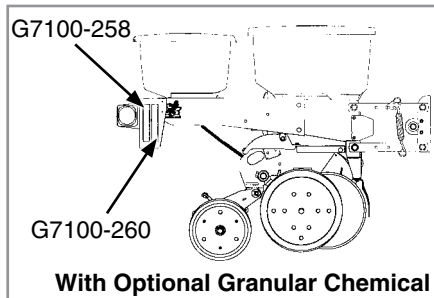
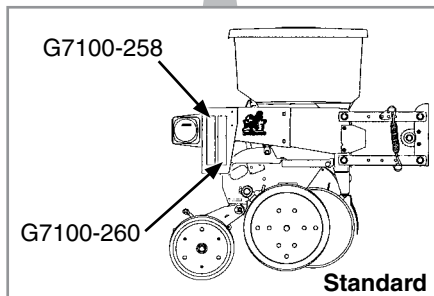
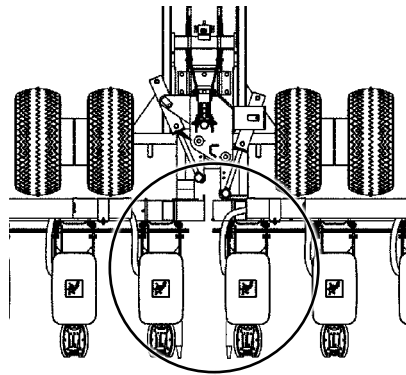

Part No.: G7100-258

Description: Reflective Decal, Red, 1½" x 9" Rectangular

Quantity: 2 (Located On The Two Center Row Units - Rear-Facing In Transport Position)

Part No.: G7100-260

Description: Reflective Decal, Orange, 1½" x 9" Rectangular

Quantity: 2 (Located On The Two Center Row Units - Rear-Facing In Transport Position)

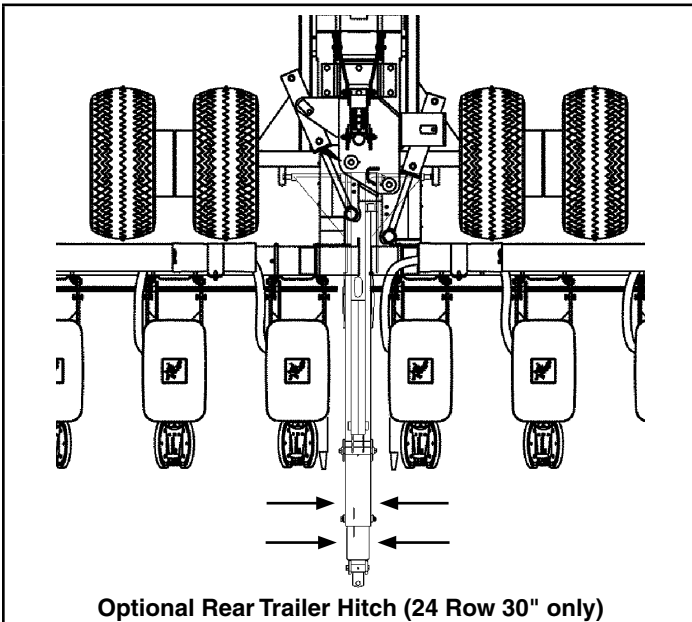



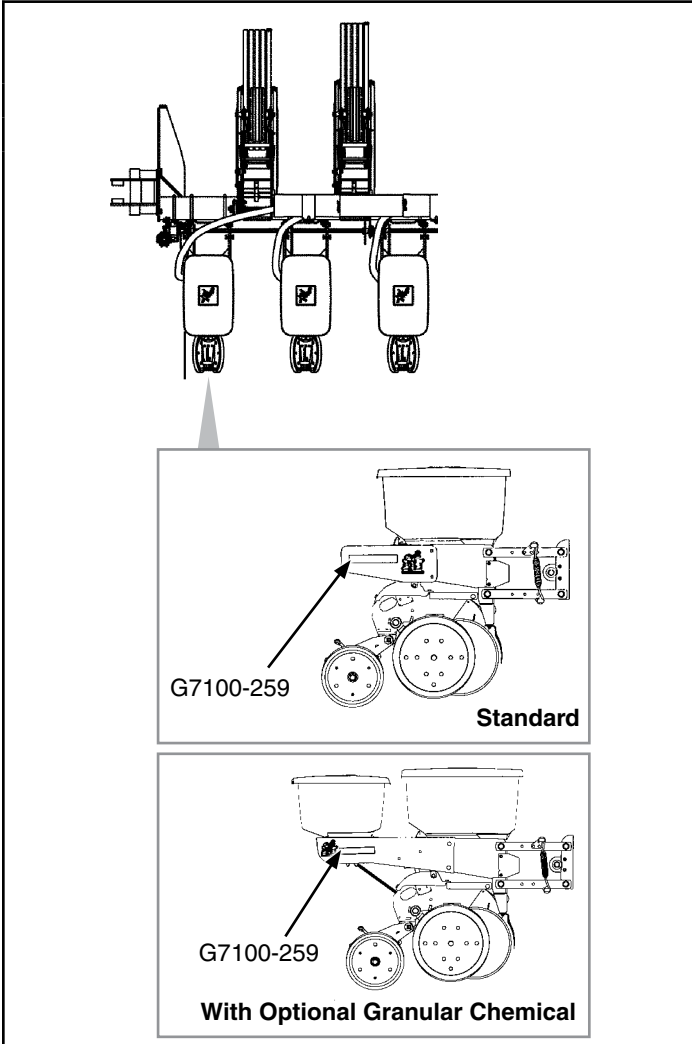





Part No.: G7100-259  
 Description: Reflective Decal, Amber, 1½" x 9", Rectangular  
 Quantity: 4

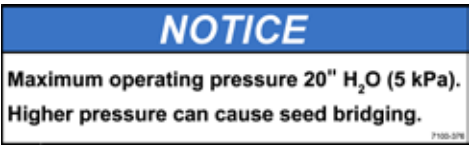
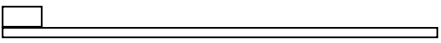







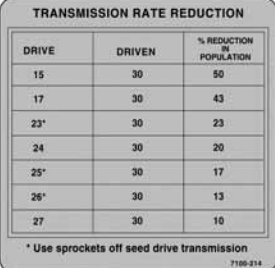
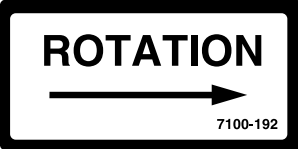
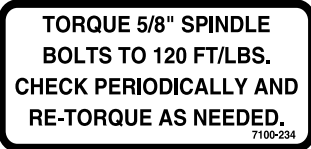
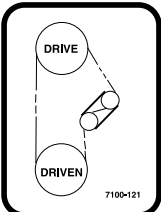
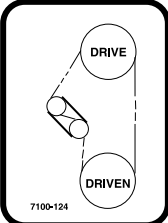
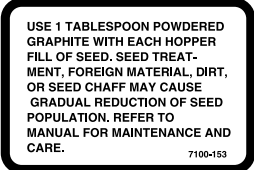

Part No.: G7100-259  
 Description: Reflective Decal, Amber, 1½" x 9", Rectangular  
 Quantity: 2 (Located On The Outside Row Unit On Each End Of The Planter - Forward-Facing In Transport Position)

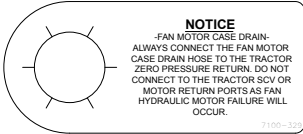
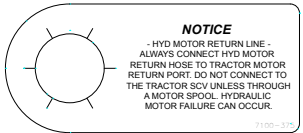

	<div data-bbox="1036 247 1321 432" style="border: 1px solid black; padding: 5px;"> <p style="text-align: center;"><b>⚠ WARNING ⚠</b></p> <p style="font-size: small;">AGRICULTURAL CHEMICALS CAN BE DANGEROUS. IMPROPER SELECTION OR USE CAN SERIOUSLY HURT OR KILL PERSONS, ANIMALS, PLANTS, SOIL, OR OTHER PROPERTY. BE SAFE. SELECT THE RIGHT CHEMICAL FOR THE JOB. HANDLE WITH CARE. FOLLOW THE INSTRUCTIONS ON THE CONTAINER LABEL AND OF THE EQUIPMENT MANUFACTURER.</p> <p style="text-align: right; font-size: x-small;">7100-115</p> </div> <p>Part No.: G7100-115                  Description: Decal, Warning                  Quantity: 1 (1 Per Row Unit - Located On Underside Of Granular Chemical Hopper Lid)</p>
	<div data-bbox="1016 688 1344 919" style="border: 1px solid black; padding: 5px;"> <p style="text-align: center;"><b>⚠ WARNING</b></p> <p style="text-align: center; font-size: x-small;">TO AVOID INJURY ...</p> <p style="font-size: x-small;">ALWAYS USE THE HYDRAULIC CYLINDER SAFETY LOCKUP CHANNEL WHEN SERVICING MACHINE IN RAISED POSITION OR WHEN TRANSPORTING MACHINE ON THE ROAD. AFTER USE RETURN TO STORAGE LOCATION.</p> <p style="text-align: right; font-size: x-small;">7100-47</p> </div> <p>Part No.: G7100-47                  Description: Decal, Warning (Prior to 2012 Production)                  Quantity: 4 (Two Per Center Lift Cylinder Lockup)</p>
	<div data-bbox="1029 1079 1331 1230" style="border: 1px solid black; padding: 5px;"> <div style="display: flex; align-items: center;"> <div style="flex: 1;">  </div> <div style="flex: 2; padding-left: 10px;"> <p style="margin: 0;"><b>⚠ WARNING</b></p> <p style="font-size: x-small; margin: 0;">Uncontrolled machine movement can crush resulting in death, serious injury, or damage to property and equipment.</p> <p style="font-size: x-small; margin: 0;">Install safety lockup devices before working under or transporting this equipment.</p> </div> </div> <p style="text-align: right; font-size: x-small; margin-top: 5px;">7100-385</p> </div> <p>Part No.: G7100-385                  Description: Decal, Warning (2012 Production and on)                  Quantity: 4 (Two Per Center Lift Cylinder Lockup)</p>
	<div data-bbox="1049 1386 1312 1650" style="border: 1px solid black; padding: 5px;"> <p style="text-align: center;"><b>⚠ WARNING ⚠</b></p> <p style="text-align: center; font-weight: bold; font-size: large;">MAXIMUM INFLATION PRESSURE 75 PSI</p> <p style="text-align: right; font-size: x-small;">7100-219</p> </div> <p>Part No.: G7100-219                  Description: Decal, Warning                  Quantity: 1 (Per Tire - Ground Drive Tires)</p>

	
<p>Part No.: G7100-377                  Description: Decal, Warning Entrapment                  Quantity: 2 (on each ASD Tank Lid)</p>	
<p>Part No.: G7100-376                  Description: Decal, Notice ASD Pressure                  Quantity: 2 (on each ASD Tank Lid)</p>	
<p>Part No.: GD1162                  Description: Tie Strap, 28"</p> <p>Part No.: GD1512                  Description: Tie Strap, 7½"</p> <p>Part No.: GD2117                  Description: Tie Strap, 14½"</p> <p>Part No.: GD2984                  Description: Tie Strap, 34"</p>	
<p>Part No.: G7100-295                  Description: Decal, Spring Tension Release                  Quantity: -</p> <p>Part No.: G7100-247                  Description: Decal, Logo, 4¾" x 4½"                  Quantity: 2 (Per Row Unit)</p> <p>Part No.: G7100-252                  Description: Decal, Logo, 3½" x 3¾" (Hopper Panel Extension)                  Quantity: -</p>	

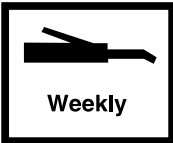
	<p>Part No.: GD10057-01 Description: Hose Identification Sleeve, Red AA</p> <p>Part No.: GD10057-02 Description: Hose Identification Sleeve, Red BB</p> <p>Part No.: GD10057-03 Description: Hose Identification Sleeve, Blue AA</p> <p>Part No.: GD10057-04 Description: Hose Identification Sleeve, Blue BB</p> <p>Part No.: GD10057-07 Description: Hose Identification Sleeve, Yellow AA</p> <p>Part No.: GD10057-08 Description: Hose Identification Sleeve, Yellow BB</p> <p>Part No.: GD10057-11 Description: Hose Identification Sleeve, Green PP</p> <p>Part No.: GD10057-12 Description: Hose Identification Sleeve, Green RR</p> <p>Part No.: GD10057-14 Description: Hose Identification Sleeve, Yellow PP</p> <p>Part No.: GD10057-15 Description: Hose Identification Sleeve, Yellow RR</p> <p>Part No.: GD10057-17 Description: Hose Identification Sleeve, Black PP</p> <p>Part No.: GD10057-18 Description: Hose Identification Sleeve, Black RR</p> <p>Part No.: GD10057-19 Description: Hose Identification Sleeve, Orange CD</p>
	<p>Part No.: G7100-341 Description: Decal, Sending Unit Quantity: 1</p>
	<p>Part No.: G7100-340 Description: Decal, Sending Unit Quantity: 1</p>
<div style="border: 1px solid black; padding: 5px;"> <p style="text-align: center;"><b>NOTE</b></p> <p><small>It is the responsibility of the user to read and understand the Operator's Manual in regards to safety, operation, lubrication and maintenance before operation of this equipment.</small></p> <p><small>AN OPERATOR &amp; PARTS MANUAL IS AVAILABLE FOR THIS MACHINE.</small></p> <p><small>To obtain a manual, furnish model number and serial number and contact your KINZE Dealer or KINZE Manufacturing, Inc., P.O. Box 806 Williamsburg, IA 52361-0806 USA</small></p> </div>	<p>Part No.: G7100-217 Description: Decal, Note Quantity: 1</p>

 <p><b>TRANSMISSION RATE REDUCTION</b></p> <table border="1"> <thead> <tr> <th>DRIVE</th> <th>DRIVEN</th> <th>% REDUCTION IN POPULATION</th> </tr> </thead> <tbody> <tr> <td>15</td> <td>30</td> <td>50</td> </tr> <tr> <td>17</td> <td>30</td> <td>43</td> </tr> <tr> <td>23*</td> <td>30</td> <td>23</td> </tr> <tr> <td>24</td> <td>30</td> <td>20</td> </tr> <tr> <td>25*</td> <td>30</td> <td>17</td> </tr> <tr> <td>26*</td> <td>30</td> <td>13</td> </tr> <tr> <td>27</td> <td>30</td> <td>10</td> </tr> </tbody> </table> <p>* Use sprockets off seed drive transmission</p> <p>7100-214</p>	DRIVE	DRIVEN	% REDUCTION IN POPULATION	15	30	50	17	30	43	23*	30	23	24	30	20	25*	30	17	26*	30	13	27	30	10	<p>Part No.: G7100-214                  Description: Decal, Two-Speed Point Row Clutch Rate Reduction</p>
DRIVE	DRIVEN	% REDUCTION IN POPULATION																							
15	30	50																							
17	30	43																							
23*	30	23																							
24	30	20																							
25*	30	17																							
26*	30	13																							
27	30	10																							
 <p><b>ROTATION</b></p> <p>→</p> <p>7100-192</p>	<p>Part No.: G7100-192                  Description: Decal, Point Row Clutch Rotation</p>																								
 <p><b>TORQUE 5/8" SPINDLE BOLTS TO 120 FT/LBS. CHECK PERIODICALLY AND RE-TORQUE AS NEEDED.</b></p> <p>7100-234</p>	<p>Part No.: G7100-234                  Description: Decal, Bolt Torque                  Quantity: -</p>																								
 <p>DRIVE</p> <p>DRIVEN</p> <p>7100-121</p>	<p>Part No.: G7100-121                  Description: Decal, Transmission, R.H.                  Quantity: 1</p>																								
 <p>DRIVE</p> <p>DRIVEN</p> <p>7100-124</p>	<p>Part No.: G7100-124                  Description: Decal, Transmission, L.H.                  Quantity: 1</p>																								
 <p>USE 1 TABLESPOON POWDERED GRAPHITE WITH EACH HOPPER FILL OF SEED. SEED TREATMENT, FOREIGN MATERIAL, DIRT, OR SEED CHAFF MAY CAUSE GRADUAL REDUCTION OF SEED POPULATION. REFER TO MANUAL FOR MAINTENANCE AND CARE.</p> <p>7100-153</p>	<p>Part No.: G7100-153                  Description: Decal, Information                  Quantity: 1 Per Brush-Type Seed Meter</p>																								
 <p><b>MARKER SPEED CONTROL</b></p> <p>↑ RAISE ↓ LOWER</p> <p>SEE MANUAL FOR PROPER ADJUSTMENT</p> <p>7100-160</p>	<p>Part No.: G7100-160                  Description: Decal, Flow Control</p>																								
 <p><b>EdgeVac®</b></p> <p>7100-311</p>	<p>Part No.: G7100-311                  Description: Decal, EdgeVac</p>																								

 <p><b>NOTICE</b> - FAN MOTOR CASE DRAIN - ALWAYS CONNECT THE FAN MOTOR CASE DRAIN HOSE TO THE TRACTOR ZERO PRESSURE RETURN. DO NOT CONNECT TO THE TRACTOR SCV OR MOTOR RETURN PORTS AS FAN HYDRAULIC MOTOR FAILURE WILL OCCUR. 7100-329</p>	<p>Part No.: G7100-329 Description: Tag, Fan Motor Case Drain</p>
 <p><b>NOTICE</b> - HYD MOTOR RETURN LINE - ALWAYS CONNECT HYD MOTOR RETURN HOSE TO TRACTOR MOTOR RETURN PORT. DO NOT CONNECT TO THE TRACTOR SCV UNLESS THROUGH A MOTOR SPOOL. HYDRAULIC MOTOR FAILURE CAN OCCUR. 7100-329</p>	<p>Part No.: G7100-375 Description: Tag, Hydraulic Motor Return Line</p>
	<p>Part No.: G7100-335 Description: Decal, Kinze Vision</p>
 <p>DRAIN MOISTURE FROM AIR TANK DAILY. DRAIN TANK COMPLETELY FOR STORAGE. 7100-352</p>	<p>Part No.: G7100-352 Description: Decal, Tank Drain</p>
 <p>DAILY 7100-111</p>	<p>Part No.: G7100-111 Description: Decal, Oil Daily</p>
 <p>DAILY 7100-116</p>	<p>Part No.: G7100-116 Description: Decal, Grease Daily</p>
 <p>Weekly</p>	<p>Part No.: G7100-110 Description: Decal, Grease Weekly</p>
	<p>Part No.: GR0155 Description: Blue Paint, Aerosol Can</p> <p>Part No.: GR0155MPP Description: Blue Paint, Twelve Aerosol Cans</p>

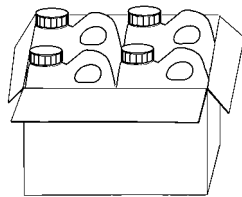
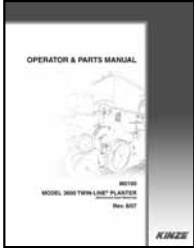
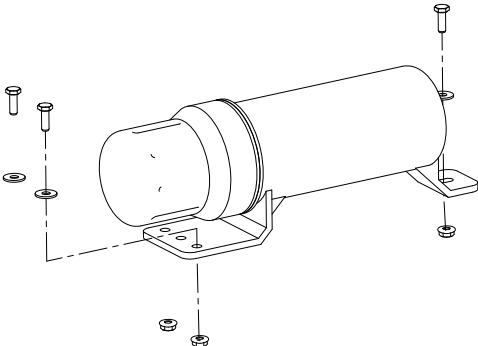
	<p>Part No.: GR0146 Description: Powdered Graphite, 1 Pound Container</p> <p>Part No.: GR0146MPP Description: Powdered Graphite, Twenty-Four 1 Pound Containers</p>
	<p>Part No.: GR1570MPP Description: Talc Lubricant, Four 8 Pound Containers</p> <p>Part No.: GR1828 Description: Talc Lubricant, 30 Pound Container</p>
	<p>Part No.: GR1842MPP Description: Graphite Lubricant, Four 5 Pound Containers</p>
<p><b>KINZE</b></p>	<p>Part No.: G7100-54 Description: Decal, Kinze, 4<sup>3</sup>/<sub>16</sub>" x 17<sup>3</sup>/<sub>16</sub>" (Prior to 2011 Production)</p>
<p><b>KINZE 3700</b></p>	<p>Part No.: G7100-246 Description: Decal, Kinze 3700 Quantity: 2 (1 on each side of hitch)</p>
<p><b><i>KINZE 3700</i></b></p>	<p>Part No.: G7100-367 Description: Decal, Kinze 3700 Quantity: 2 (1 on each side of hitch)</p>
	<p>Part No.: GM0233-01 Description: Operator Manual, Model 3700</p> <p>Part No.: GM0233-02 Description: Parts Manual, Model 3700</p>
	<p>Part No.: GA15422 Description: Operator's Manual Canister Quantity: 1</p> <p>Part No.: G11356 Description: Hex Socket Flange Cap Screw, 1/4"-20 x 1/2" Quantity: 3</p>